

REV	ECN #	DESCRIPTION	DATE	BY
1	XXXX	FOR PRICING	08/13/19	JB

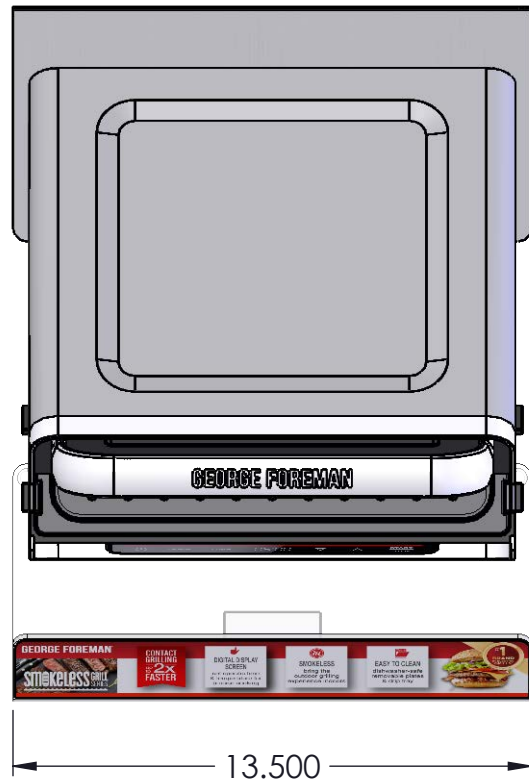

**10 PAGE
ENGINEERING
BINDER FOR
PRICING**

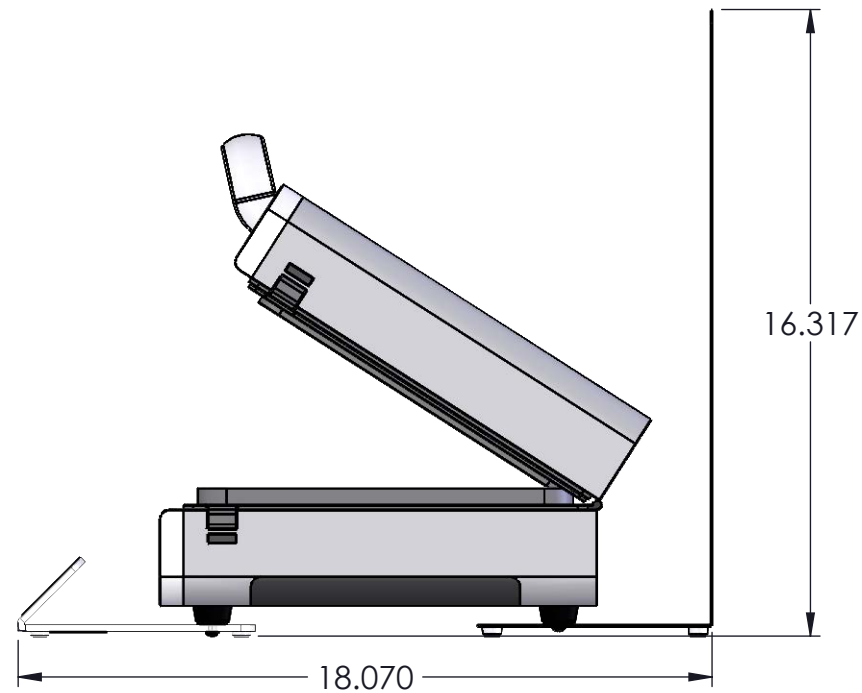

TOLERANCES UNLESS OTHERWISE NOTED XXX ± .015 XX ± .030 HOLE ± .005 ANGLE ± 1°		TITLE GEORGE FOREMAN GRD6090B KOHLS/BBB	
DESIGNED JB	DRAWN JB	MATERIAL N/A	PART NO PXXXXX
DATE 08/13/19	DATE 08/13/19	FINISH N/A	SHEET 1 OF 2

REV	ECN #	DESCRIPTION	DATE	BY
1	XXXX	FOR PRICING	08/13/19	JB

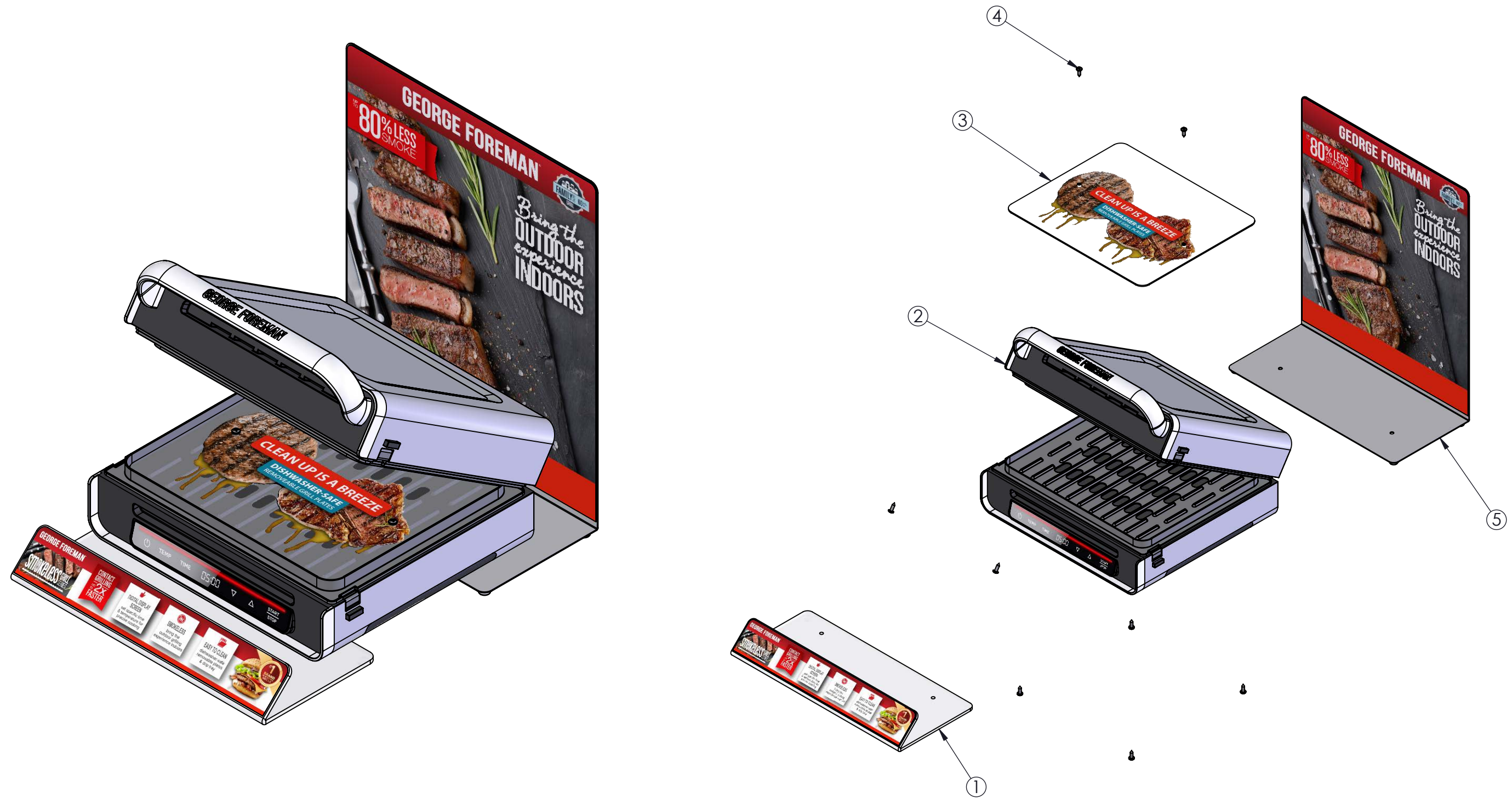

ITEM NO.	PART NO.	DESCRIPTION	QTY.
5	PXXXXX	BACKER SUB-ASSEMBLY	1
4	P36740	SHEET METAL SCREW 8 X 1/2 PHILLIP PAN HEAD TYPE B BLACK OXIDE	8
3	PXXXXX	GRAPHIC ON GRILL 1	1
2	PXXXXX	George Foreman Grill GRD6090B	1
1	PXXXXX	ACRYLIC SLED KOHLS ASSEMBLY	1

TOLERANCES UNLESS OTHERWISE NOTED		TITLE	
XXX ± .015		GEORGE FOREMAN GRD6090B KOHLS/BBB	
XX ± .030		DESIGNED	DRAWN
HOLE ± .005		JB	JB
ANGLE ± 1°		DATE	DATE
		08/13/19	08/13/19
		MATERIAL	FINISH
		N/A	N/A
		PART NO.	
		PXXXXX	
		SHEET 2 OF 2	

REV	ECN #	DESCRIPTION	DATE	BY
1	XXXX	FOR PRICING	08/13/19	JB

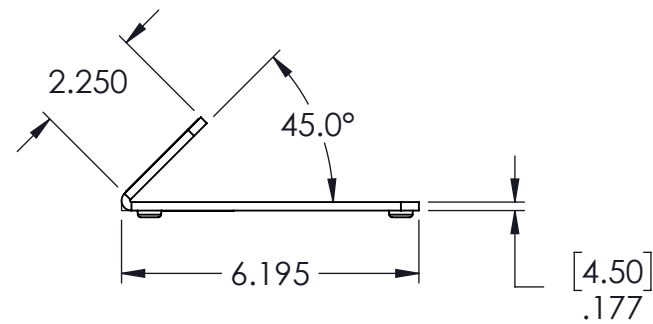
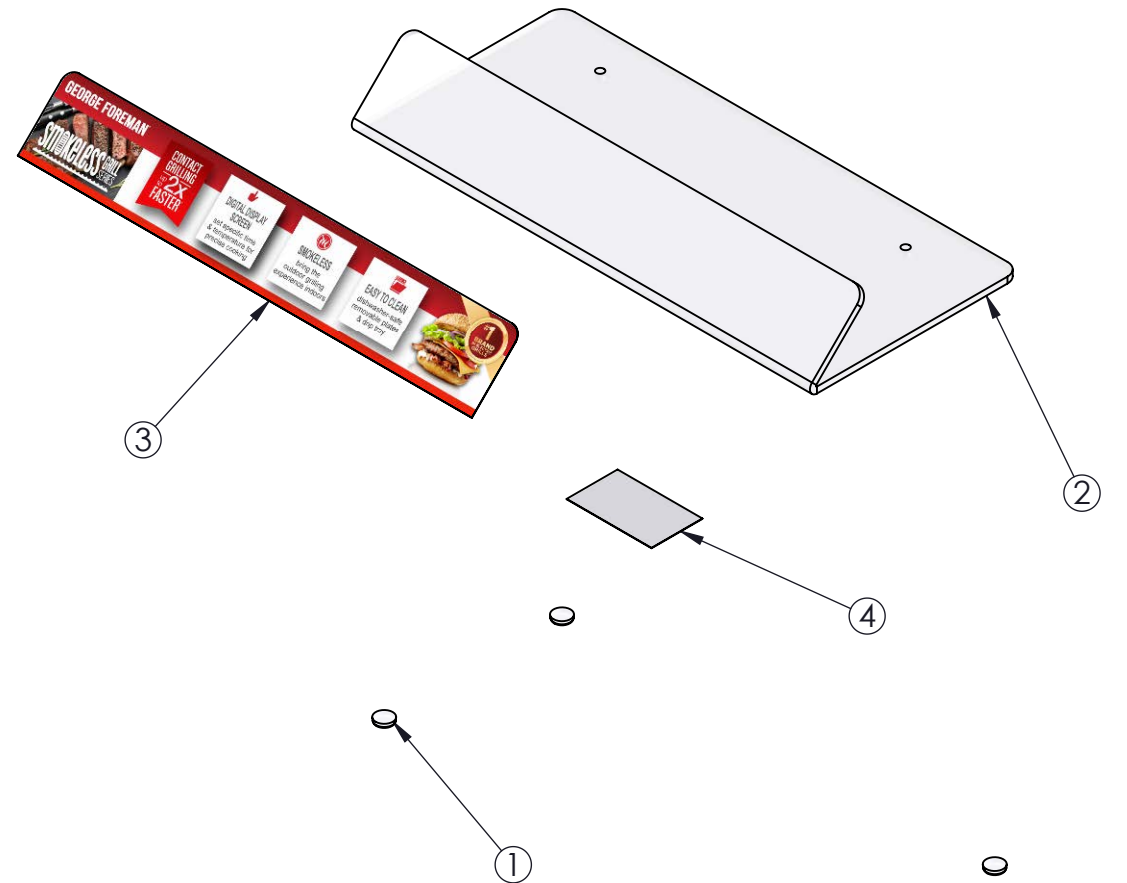
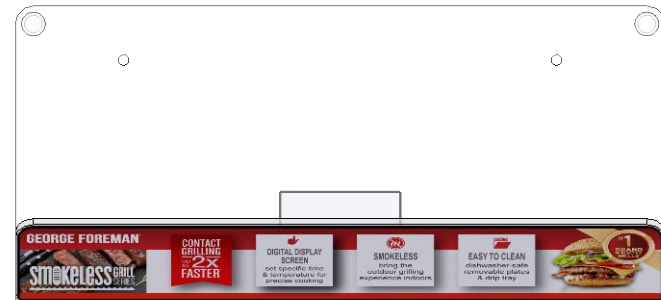
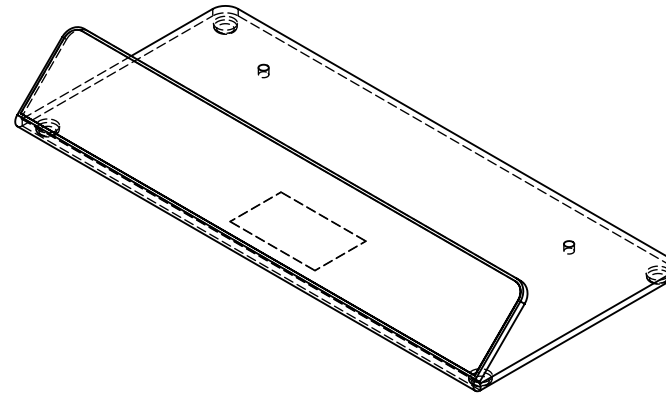

ITEM NO.	PART NO.	DESCRIPTION	QTY.
4	PXXXXX	ACRYLIC SLED KOHLS DNI LABEL	1
3	PXXXXX	GRAPHIC ACRYLIC SLED KOHLS	1
2	PXXXXX	ACRYLIC SLED KOHLS	1
1	PXXXXX	CLEAR RUBBER BUMPERS 1/2" DIAM X 0.14" THICK	4

TOLERANCES UNLESS OTHERWISE NOTED XXX ± .015 XX ± .030 HOLE ± .005 ANGLE ± 1°		TITLE ACRYLIC SLED KOHLS ASSEMBLY	
DESIGNED JB	DRAWN JB	MATERIAL N/A	PART NO. PXXXXX
DATE 08/13/19	DATE 08/13/19	FINISH N/A	SHEET 1 OF 1

REV	ECN #	DESCRIPTION	DATE	BY
1	XXXX	FOR PRICING	08/13/19	JB

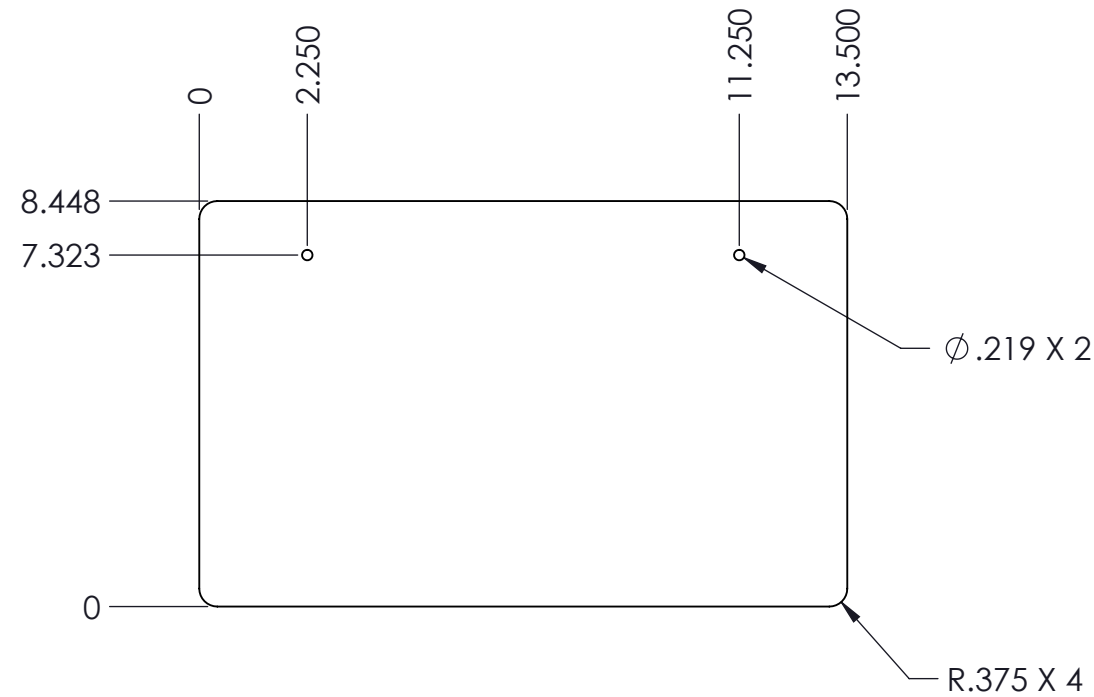
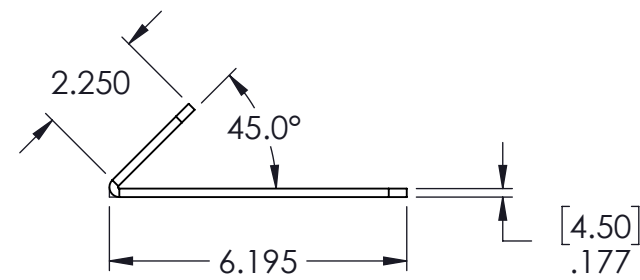
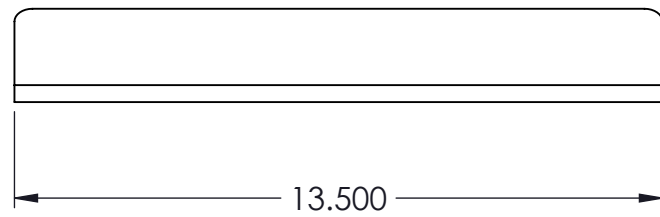
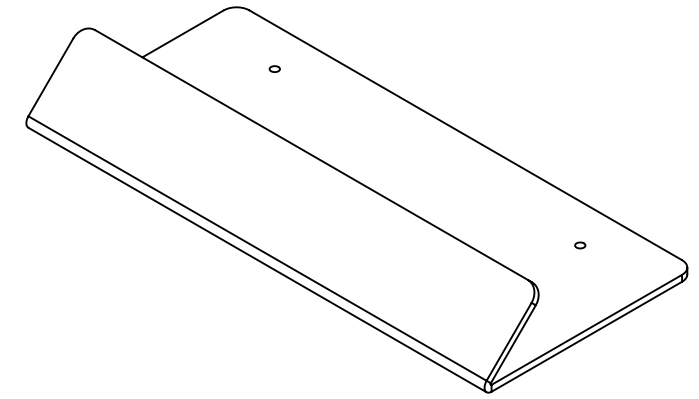
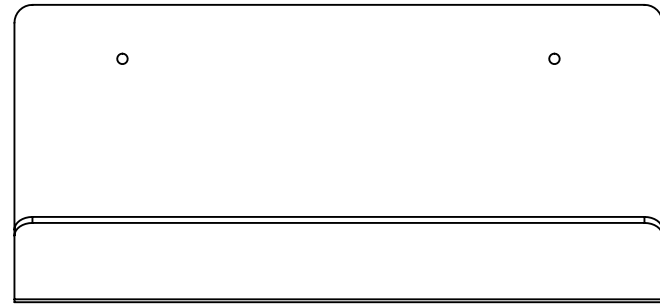

TOLERANCES UNLESS OTHERWISE NOTED XXX ± .015 XX ± .030 HOLE ± .005 ANGLE ± 1°		TITLE ACRYLIC SLED KOHLS	
DESIGNED JB	DRAWN JB	MATERIAL ACRYLIC	PART NO PXXXXX
DATE 08/13/19	DATE 08/13/19	FINISH CLEAR	SHEET 1 OF 1

REV	ECN #	DESCRIPTION	DATE	BY
1	XXXX	FOR PRICING	08/13/19	JB



TOLERANCES UNLESS OTHERWISE NOTED XXX ± .015 XX ± .030 HOLE ± .005 ANGLE ± 1°		TITLE GRAPHIC ACRYLIC SLED KOHLs	
DESIGNED JB	DRAWN JB	MATERIAL STYRENE	PART NO PXXXXX
DATE 08/13/19	DATE 08/13/19	FINISH PRINTED AND FULL PSA BACKER	SHEET 1 OF 1

REV	ECN #	DESCRIPTION	DATE	BY
1	XXXX	FOR PRICING	08/13/19	JB

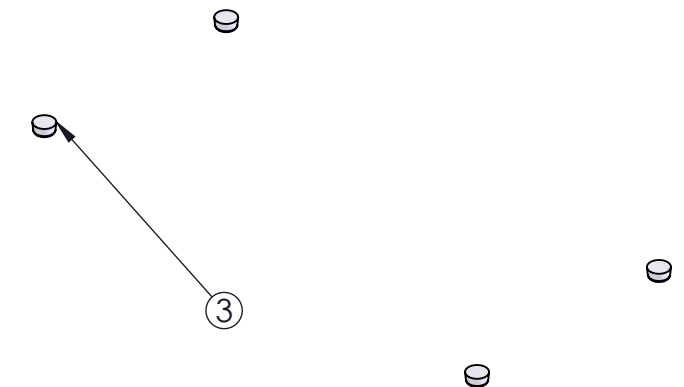
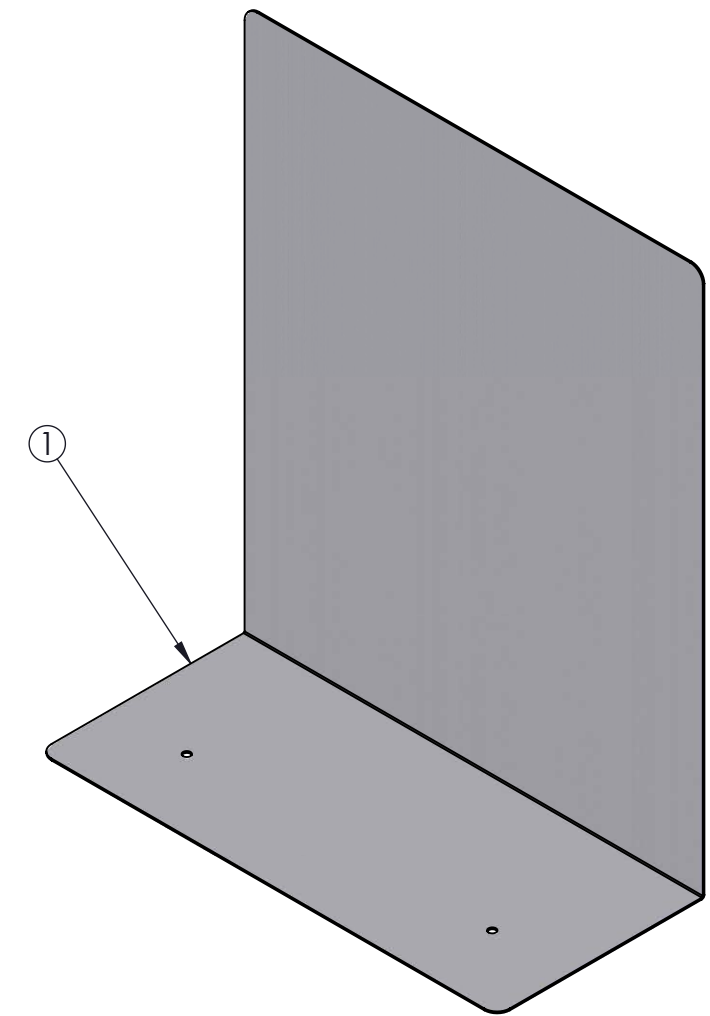
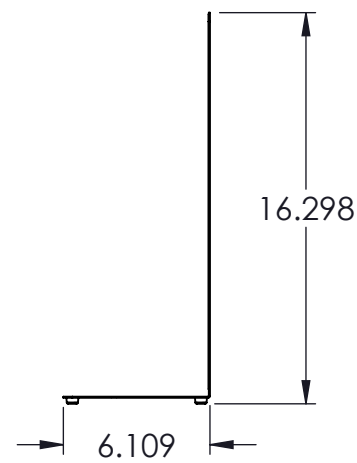
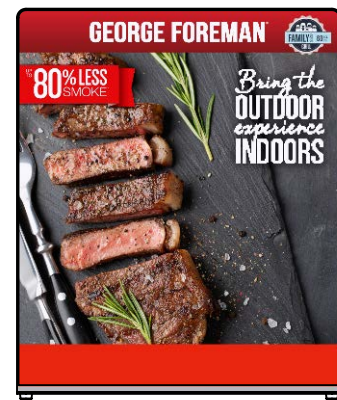
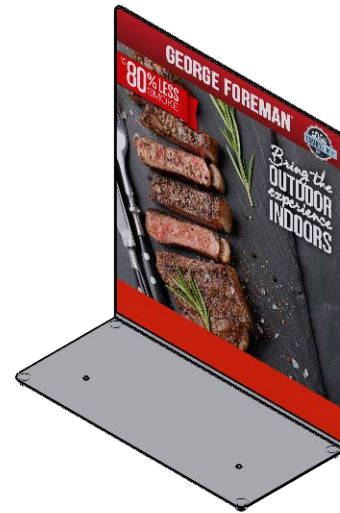
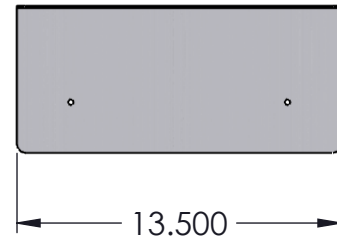

ITEM NO.	PART NO.	DESCRIPTION	QTY.
3	PXXXXX	CLEAR RUBBER BUMPERS 1/2" DIAM X 0.25" THICK	4
2	PXXXXX	GRAPHIC BACKER KOHLS	1
1	PXXXXX	BACKER	1

TOLERANCES UNLESS OTHERWISE NOTED XXX ± .015 XX ± .030 HOLE ± .005 ANGLE ± 1°		TITLE BACKER SUB-ASSEMBLY	
DESIGNED JB	DRAWN JB	MATERIAL N/A	PART NO. PXXXXX
DATE 08/13/19	DATE 08/13/19	FINISH N/A	SHEET 1 OF 1

REV	ECN #	DESCRIPTION	DATE	BY
1	XXXX	FOR PRICING	08/13/19	JB

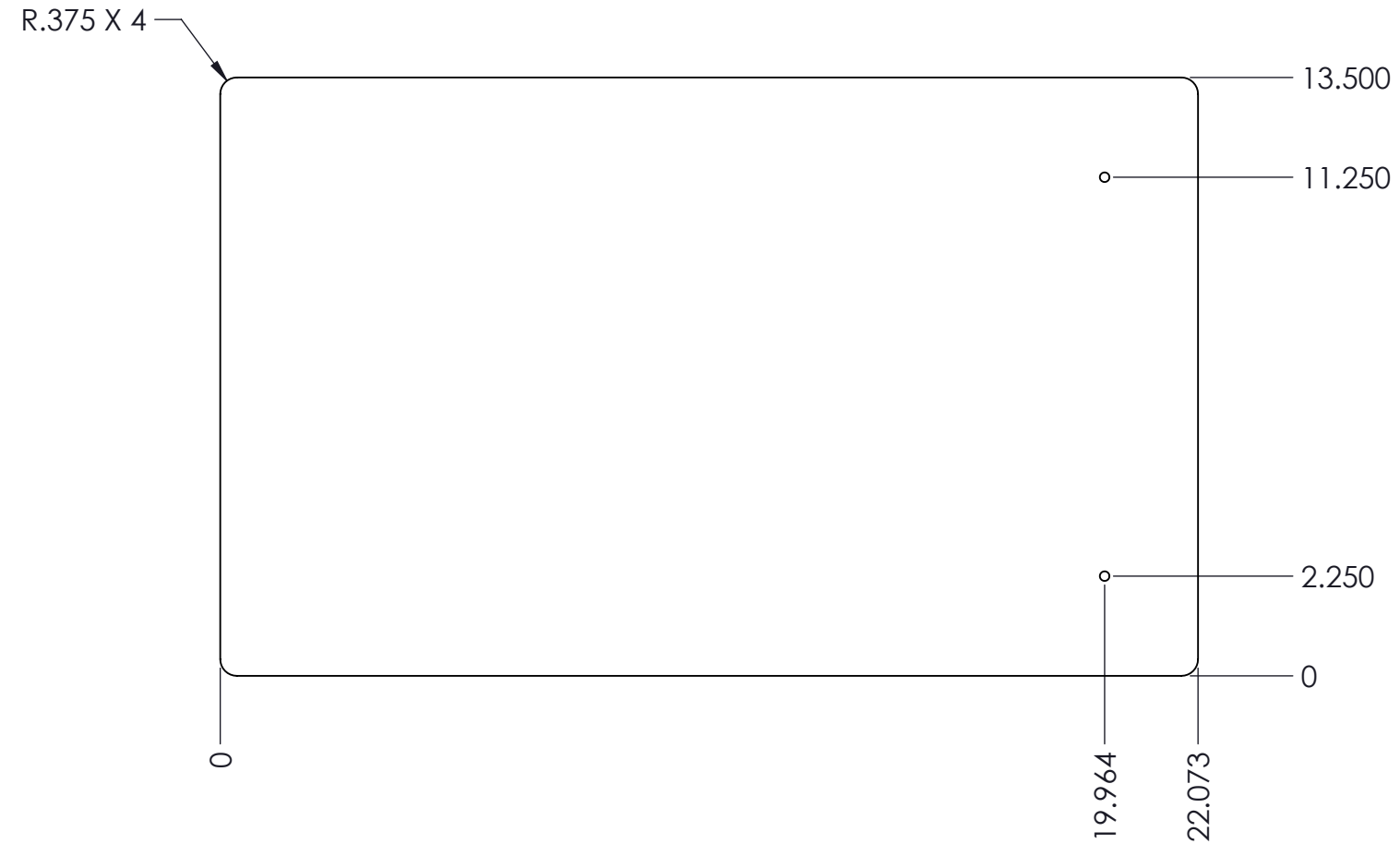
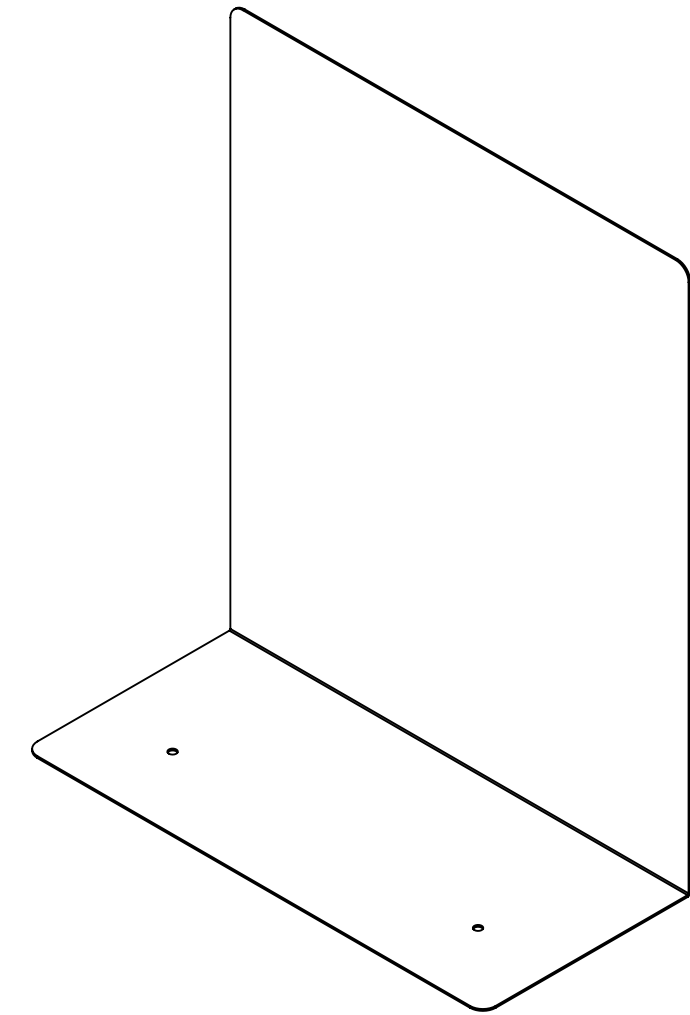
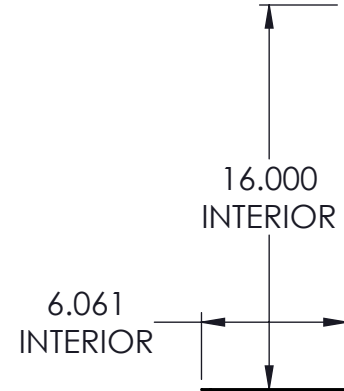
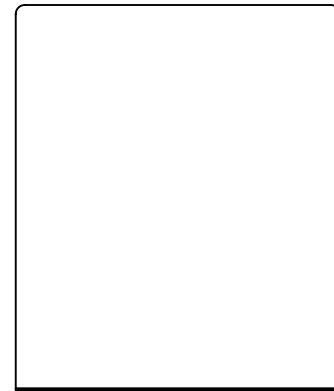
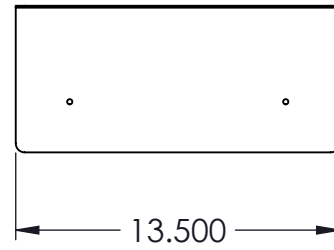

TOLERANCES UNLESS OTHERWISE NOTED XXX ± .015 XX ± .030 HOLE ± .005 ANGLE ± 1°		TITLE BACKER	
DESIGNED JB	DRAWN JB	MATERIAL 18 GA (.048) CRS	PART NO PXXXXX
DATE 08/13/19	DATE 08/13/19	FINISH SKY WHITE	SHEET 1 OF 1

REV	ECN #	DESCRIPTION	DATE	BY
1	XXXX	FOR PRICING	08/13/19	JB

R.313 X 2



15.625

13.375

.010



TOLERANCES UNLESS OTHERWISE NOTED XXX ± .015 XX ± .030 HOLE ± .005 ANGLE ± 1°		TITLE GRAPHIC BACKER KOHLS	
DESIGNED JB	DRAWN JB	MATERIAL STYRENE	PART NO PXXXXX
DATE 08/13/19	DATE 08/13/19	FINISH PRINTED AND FULL PSA BACKER	SHEET 1 OF 1

REV	ECN #	DESCRIPTION	DATE	BY
1	XXXX	FOR PRICING	08/01/19	JB

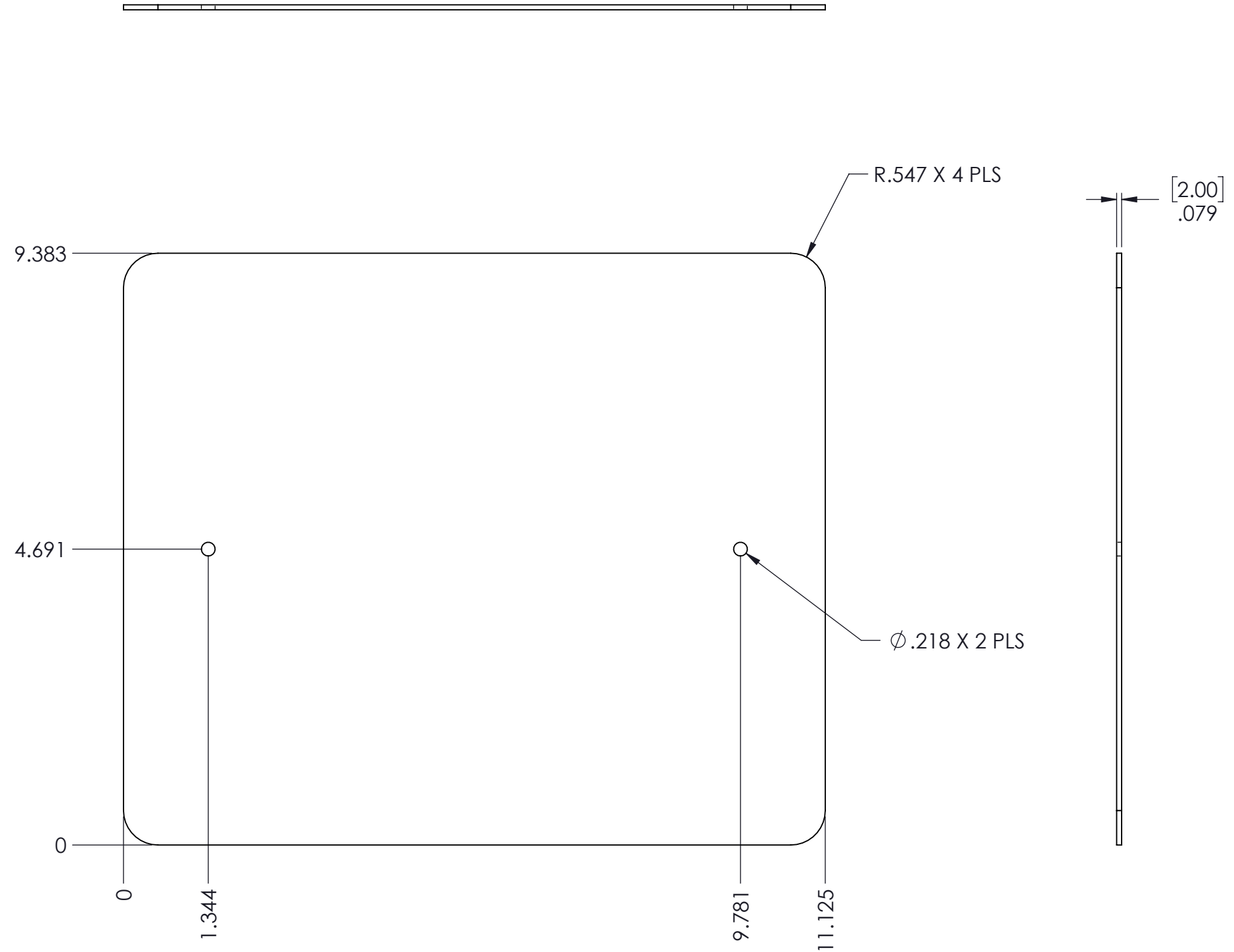

PRINT FRONT SIDE ON CLEAR 2MM PETG

TOLERANCES UNLESS OTHERWISE NOTED XXX ± .015 XX ± .030 HOLE ± .005 ANGLE ± 1°		TITLE GRAPHIC ON GRILL 1	
DESIGNED JB	DRAWN JB	MATERIAL PETG	PART NO PXXXXX
DATE 08/01/19	DATE 08/01/19	FINISH PRINTED ON CLEAR	SHEET 1 OF 1

REV	ECN #	DESCRIPTION	DATE	BY
1	XXXX	FOR PRICING	08/09/19	JB

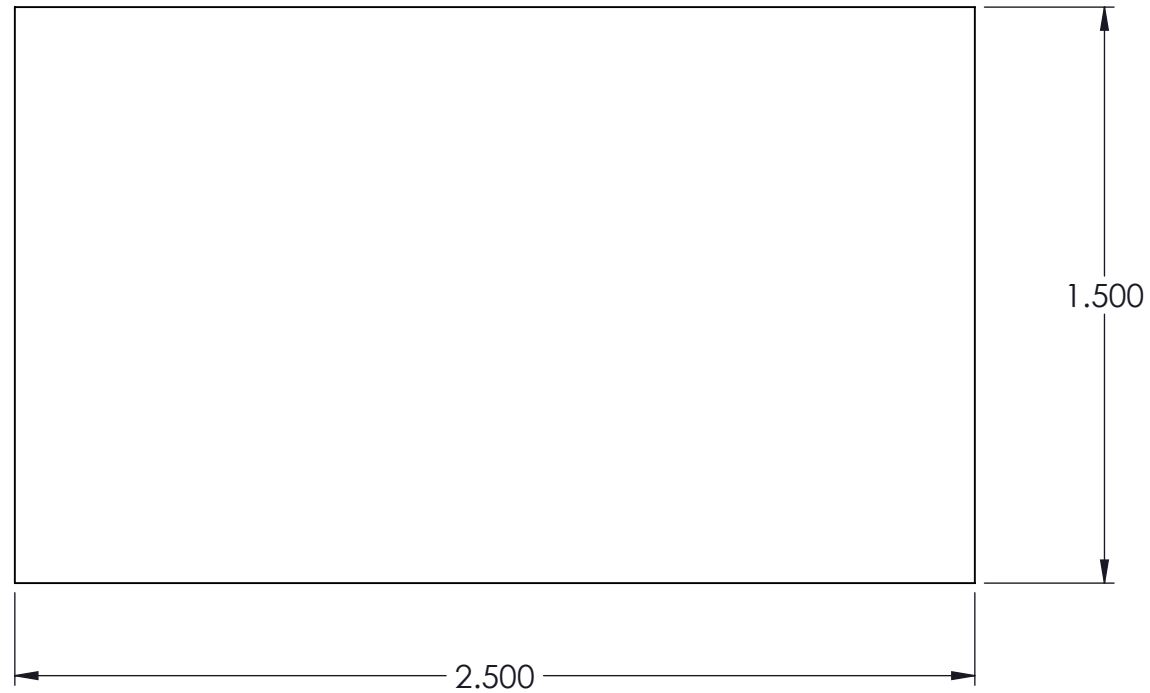

BLACK COPY ON WHITE VINYL DECAL

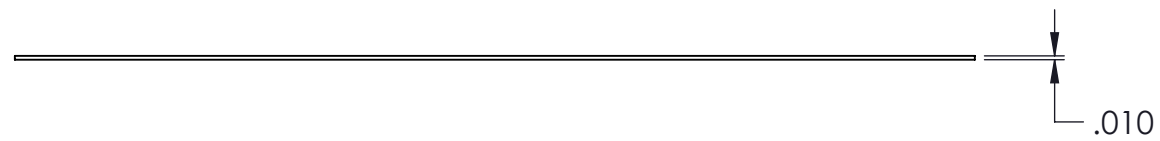

TOLERANCES UNLESS OTHERWISE NOTED XXX ± .015 XX ± .030 HOLE ± .005 ANGLE ± 1°		TITLE ACRYLIC SLED KOHLS DNI LABEL	
DESIGNED JB	DRAWN JB	MATERIAL VINYL	PART NO PXXXXX
DATE 08/01/19	DATE 08/09/19	FINISH PRINTED VINYL DECAL	SHEET 1 OF 1