

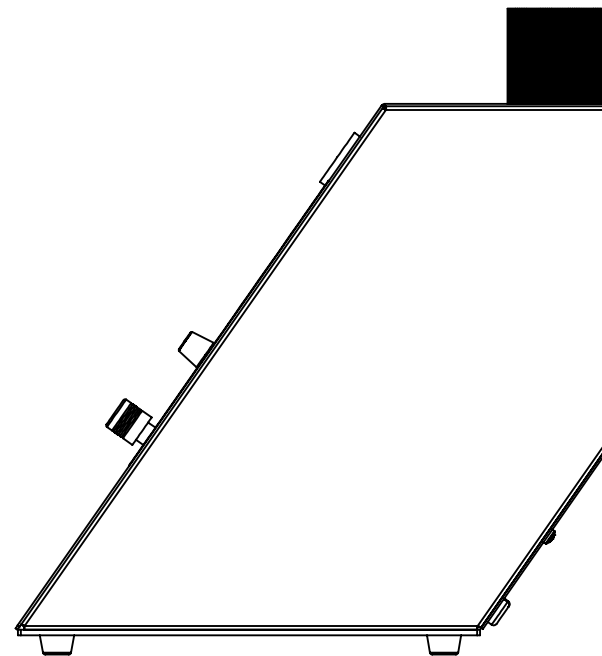

REV	ECN #	DESCRIPTION	DATE	BY
1	XXX	DESIGN INTENT FOR ENGINEERING	12/20/17	JB

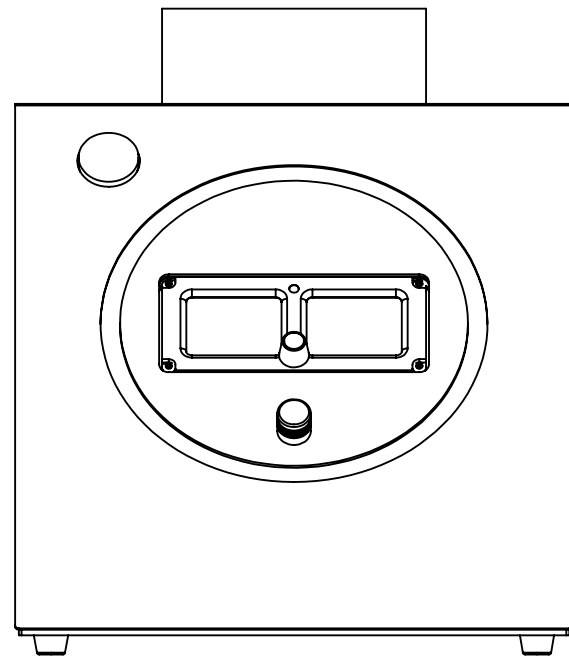

# 46 PAGE ENGINEERING BINDER

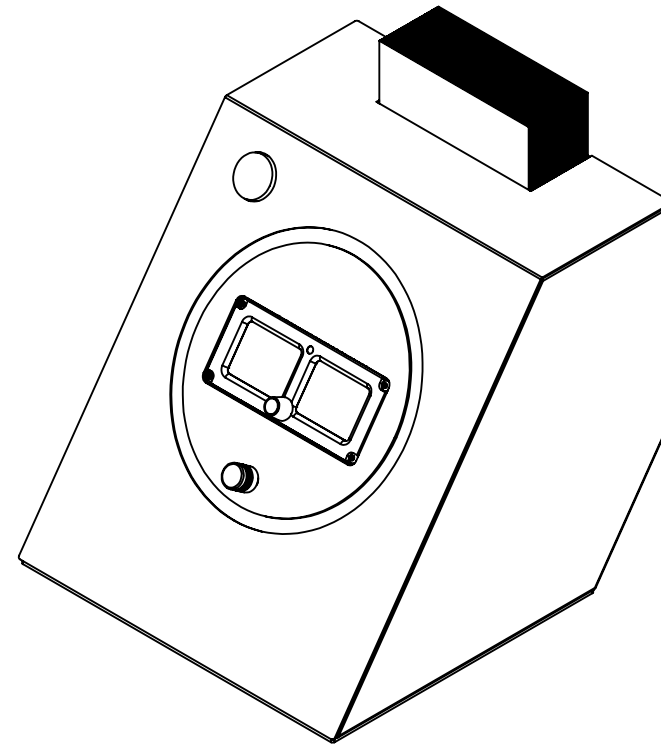
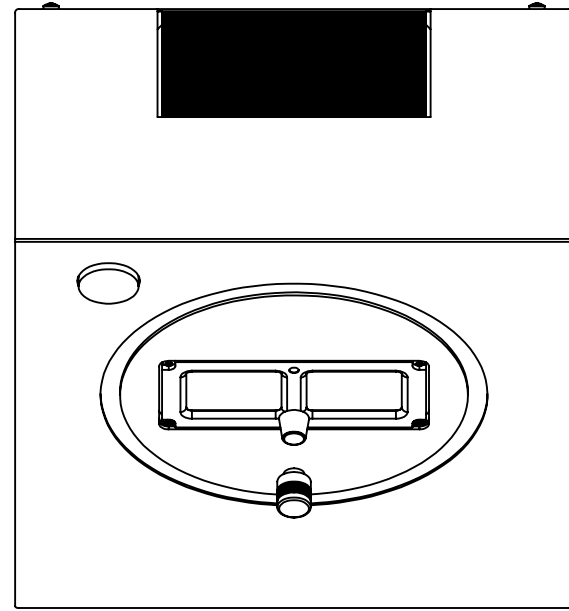

ITEM NO.	PART NUMBER	DESCRIPTION	QTY.
1	Assem22	SAM DISPLAY ASSEMBLY	1
2	Brochure_SAM_2	FLY SAM BROCHURE (FBC)	50

TOLERANCES UNLESS OTHERWISE NOTED XXX ± .015 XX ± .030 HOLE ± .005 ANGLE ± 1°		 AMD Industries Inc. 4620 West 19th Street, Cicero, IL 60804	
DESIGNED JB		TITLE SAM DISPLAY WITH BROCHURES	
DATE 12/07/17		PART NO PXXXXX	
DRAWN JB		MATERIAL N/A	
DATE 12/20/17		FINISH XXXXXXXXXX	
		SHEET 1 OF 2	

## MIDCONTINENT SAM DISPLAY - PARTS NEEDED PER UNIT

ITEM NO.	PART NUMBER	DESCRIPTION	Material	Finish	QTY.
1	Part1a	FRONT	18 GA (.048) CRS	XXXXXXXXXXX	1
2	Part20	SIDE LEFT	18 GA (.048) CRS	N/A	1
3	P62476	PEM STUD SELF CLINCH FLUSH 8-32 X 5/8" #FH-832-10 ZI	STEEL		1
4	P36073	PEM STUD SELF CLINCH FLUSH 8-32 X 5/16" #FH-832-5 ZI	STEEL		8
5	P33383	PEM NUT SELF CLINCH 8-32 X .038" PEM #S-832-1ZI	STEEL		14
6	Part21	SIDE RIGHT	18 GA (.048) CRS	N/A	1
7	Part15	ACRYLIC LOGO CIRCLE	ACRYLIC	2051 BLUE TRANSLUCENT	1
8	Part16	ACRYLIC LOGO BACKER	ACRYLIC	2051 BLUE TRANSLUCENT	1
9	Part17	LED LIGHT BOX	18 GA (.048) CRS	WW WHITE OR EQUIVALENT	1
10	P10127	WING NUT 8-32 ZINC	STEEL		1
11	Part23	BRACKET	16 GA (.060) CRS	N/A	2
12	P11254	KEP NUT 8-32 ZINC	STEEL		12
13	Part14	BOTTOM COVER	11 GA (.120) CRS	BLACK MINI TEX	1
14	P12897	RUBBER FEET 3/4" DIAMETER X 3/8" BLACK 741 RW	RUBBER	XXXXXXXXXXX	4
15	P26521	MACHINE SCREW 8-32 X 3/8 PHILLIP PAN HEAD BLACK OXIDE	STEEL		10
16	P13547	MACHINE SCREW 8-32 X 1/2 PHILLIP PAN HEAD BLACK OXIDE	STEEL		1
17	1797K210_EASY-POSITION TURNTABLE-side_2	PART OF McMaster Carr #1797K210			1
18	1797K210_EASY-POSITION TURNTABLE-side_1	PART OF McMaster Carr #1797K210			1
19	Part19	FIXED TURNTABLE BRACKET	18 GA (.048) CRS	XXXXXXXXXXX	1
20	P33318	PEM NUT SELF CLINCH 10-24 X .038" #SS-024-1 ZI	STEEL		4
21	P19709	MACHINE SCREW 8-32 X 3/8 PHILLIP PAN HEAD ZINC	STEEL		8
22	Part5	ROTATING BRACKET WITH TABS	18 GA (.048) CRS	XXXXXXXXXXX	1
23	P33752	PEM STUD SELF CLINCH FLUSH 8-32 X 1/2" #FH-832-8 ZI	Material <not specified>		4
24	Part13	TWINSTICK 0.020" X 1.5" X .375"	ACRYLIC	XXXXXXXXXXX	6
25	Part4	SAM UNIT BEZEL	14 GA (.075) CRS	BLACK MINI TEX	1
26	Part18	BLACK STYRENE WITH FULL BACK ADHESIVE	STYRENE	BLACK	1
27	KNOB-16418-SS OUTWATER 304 SS 8-32X1 SCREW INCL	KNOB-16418-SS OUTWATER 304 SS 8-32X1 SCREW INCL	304-2B STAINLESS	XXXXXXXXXXX	1
28	SAM_MD302_6420302_JASON	SAM MD302 (FBC)			1
29	Default	MACHINE SCREW 6-32 X 3/8" TAMPER RESISTANT PIN-IN-TORX SOCKET BUTTON HEAD BLACK OXIDE	0.002	N/A	4
30	FBC_DD15S10JVLO	RS232 CONNECTOR - NO. DD15S10JVLO (FBC)	Material <not specified>	N/A	1
31	FBC_wire_to_barrel	XXXXXXXXXXX			1
32	Part10	SPACER	SINTRA	BLACK	1
33	Part11	TURNTABLE BRACKET	18 GA (.048) CRS	BLACK MINI TEX	1
34	P33745	PEM NUT SELF CLINCH 6-32 X .038" #S-632-1 ZI	STEEL		4
35	Part22	BACK COVER	18 GA (.048) CRS	BLACK MINI TEX	1
36	Part3	BROCHURE POCKET	18 GA (.048) CRS		1
37	74125K710_SNAP-IN CORD GRIP (1)	SNAP-IN PLASTIC CORD GRIP - MCMaster-CARR #74125K71	Material <not specified>	XXXXXXXXXXX	1
38	Brochure_SAM_2	FLY SAM BROCHURE (FBC)			50

REV	ECN #	DESCRIPTION	DATE	BY
1	XXX	DESIGN INTENT FOR ENGINEERING	12/20/17	JB

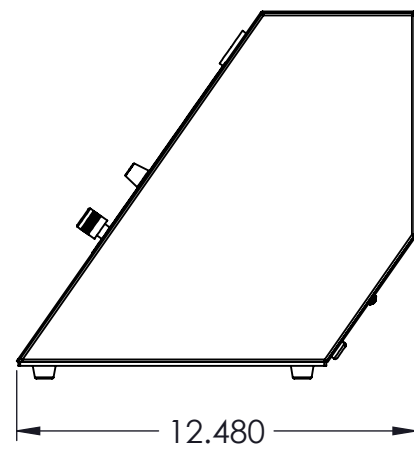
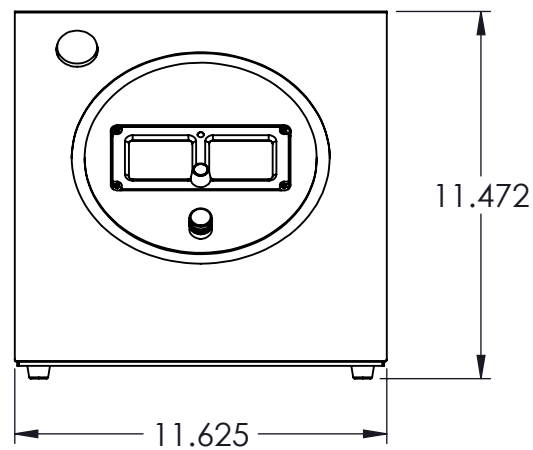
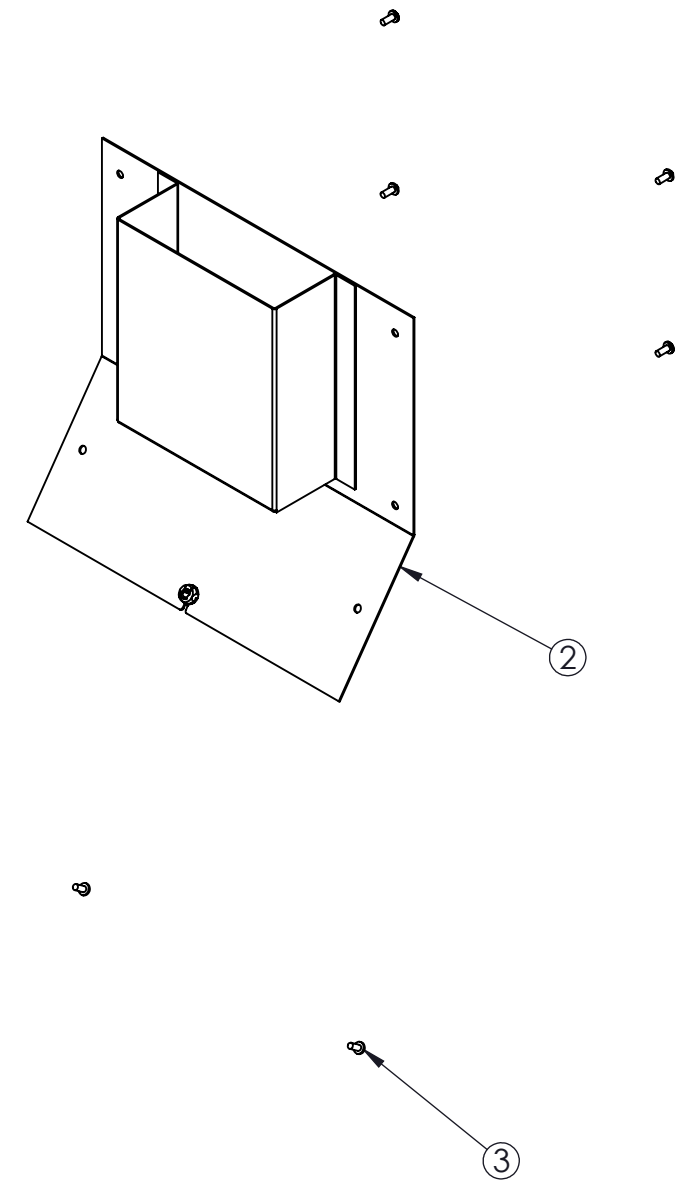
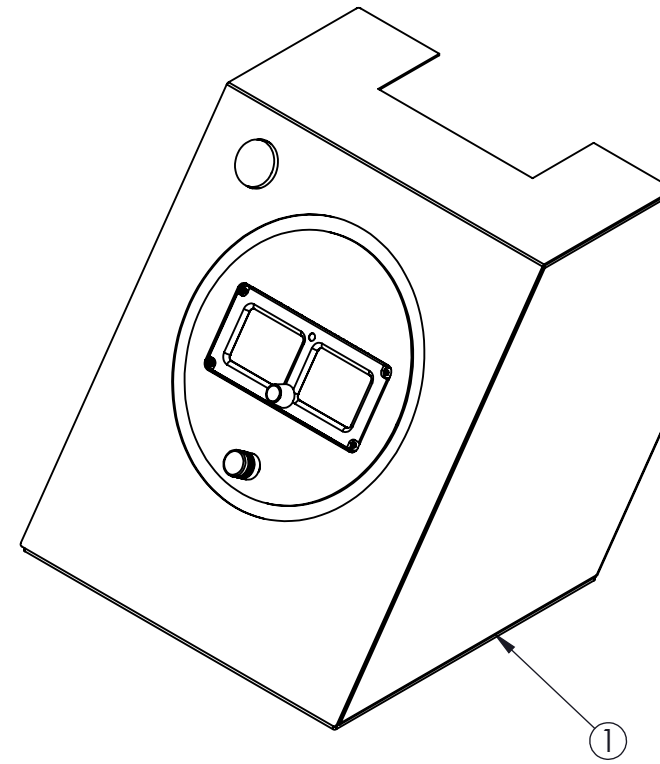
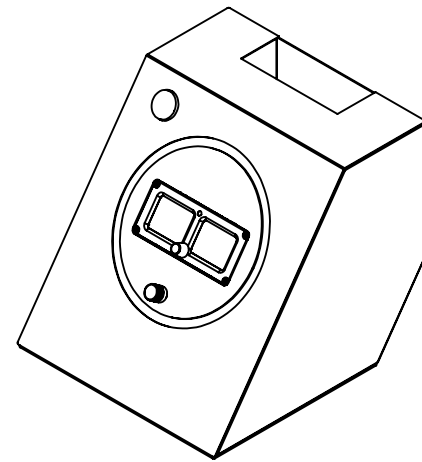
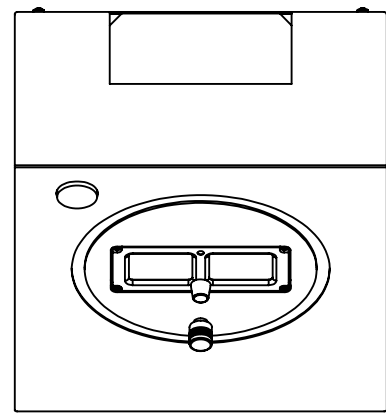

ITEM NO.	PART NUMBER	DESCRIPTION	QTY.
1	Assem21	SAM DISPLAY SUBASSEMBLY	1
2	Assem25	BACK COVER ASSEMBLY	1
3	P26521	MACHINE SCREW 8-32 X 3/8 PHILLIP PAN HEAD BLACK OXIDE	6

TOLERANCES UNLESS OTHERWISE NOTED XXX ± .015 XX ± .030 HOLE ± .005 ANGLE ± 1°		 AMD Industries Inc. 4620 West 19th Street, Cicero, IL 60804	
TITLE SAM DISPLAY ASSEMBLY			
DESIGNED JB	DRAWN JB	MATERIAL N/A	PART NO PXXXXX
DATE 12/07/17	DATE 12/20/17	FINISH XXXXXXXXXX	SHEET 1 OF 1

REV	ECN #	DESCRIPTION	DATE	BY
1	XXX	DESIGN INTENT FOR ENGINEERING	12/20/17	JB

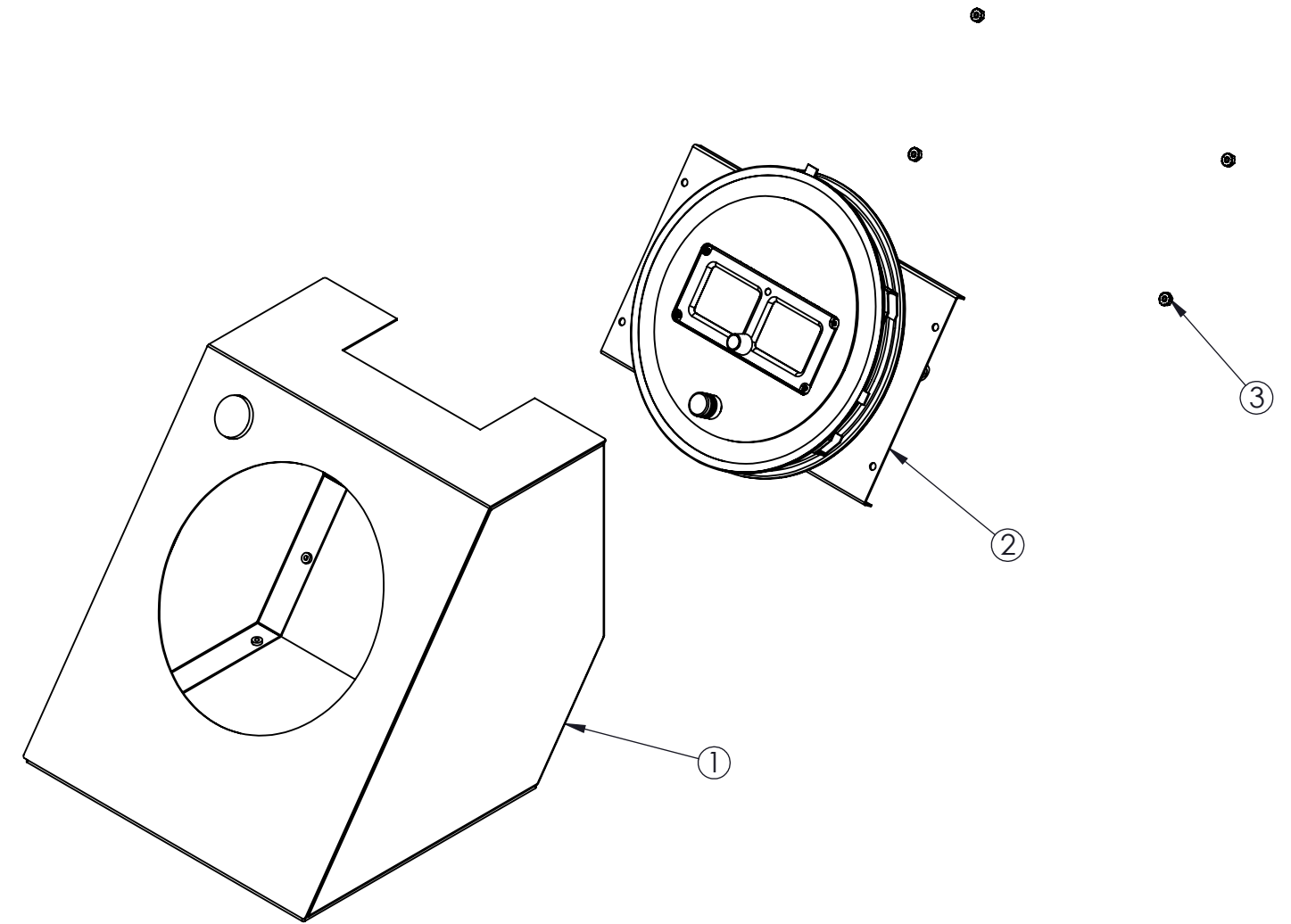
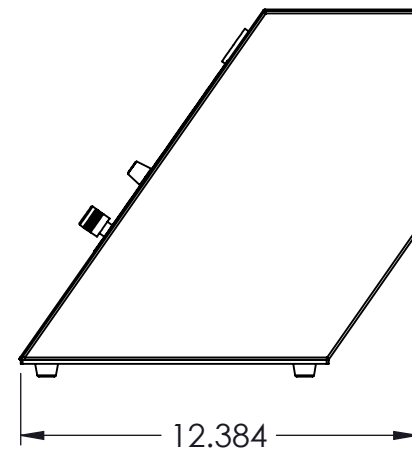
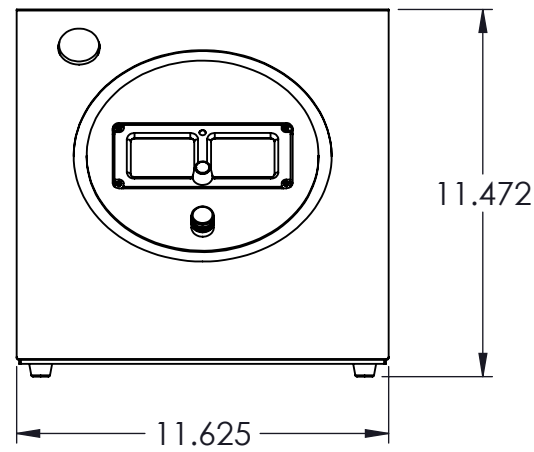
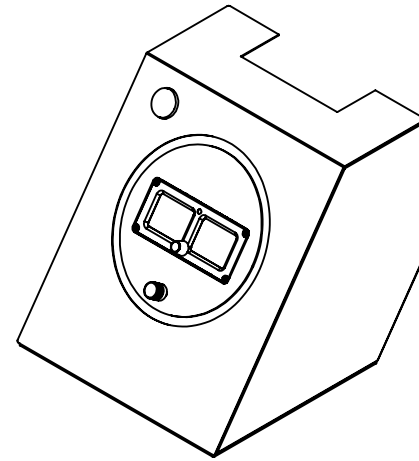
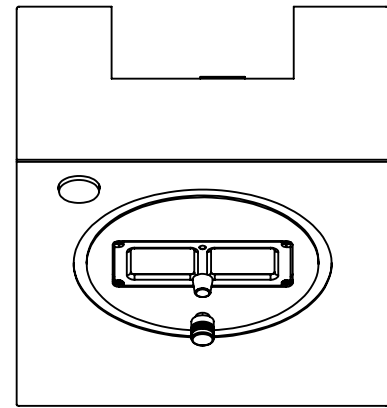

ITEM NO.	PART NUMBER	DESCRIPTION	QTY.
1	Assem20	MAIN BODY ASSEMBLY	1
2	Assem15	ROTATING ASSEMBLY	1
3	P11254	KEP NUT 8-32 ZINC	4

TOLERANCES UNLESS OTHERWISE NOTED XXX ± .015 XX ± .030 HOLE ± .005 ANGLE ± 1°		 AMD Industries Inc. 4620 West 19th Street, Cicero, IL 60804	
TITLE SAM DISPLAY SUBASSEMBLY			
DESIGNED JB	DRAWN JB	MATERIAL N/A	PART NO PXXXXX
DATE 12/07/17	DATE 12/20/17	FINISH XXXXXXXXXX	SHEET 1 OF 1

REV	ECN #	DESCRIPTION	DATE	BY
1	XXX	DESIGN INTENT FOR ENGINEERING	12/20/17	JB

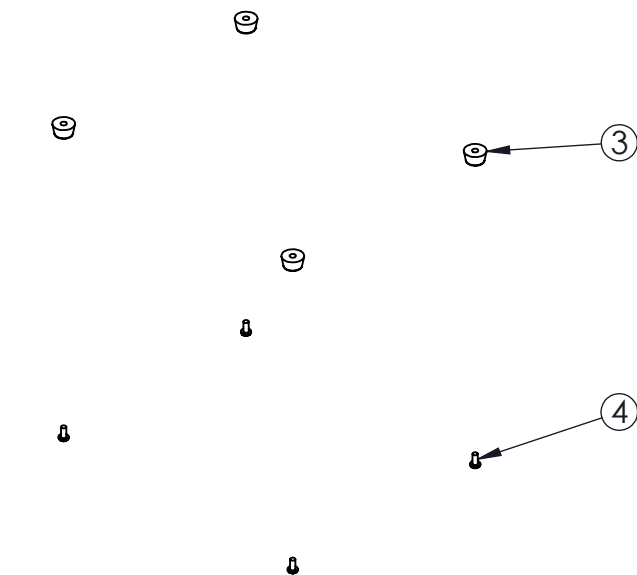
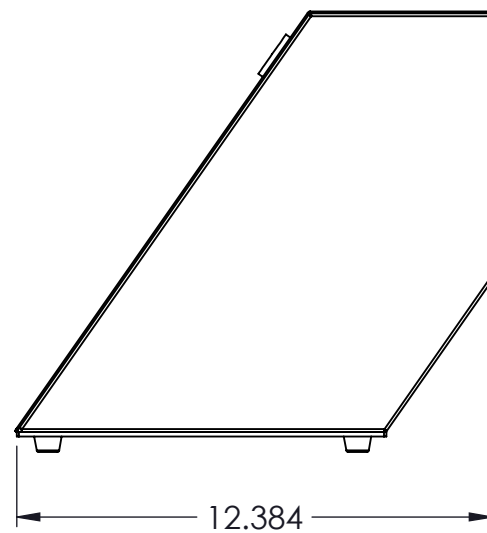
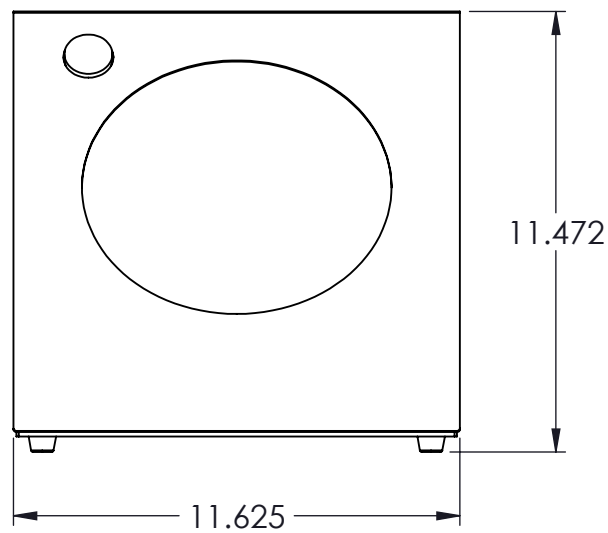
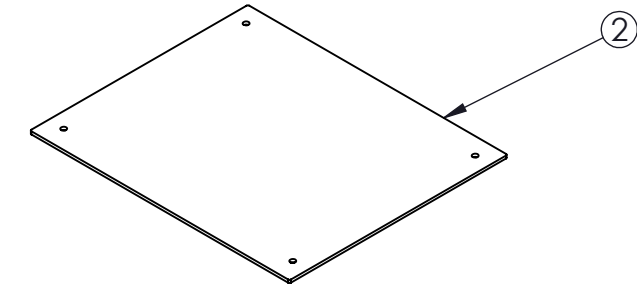
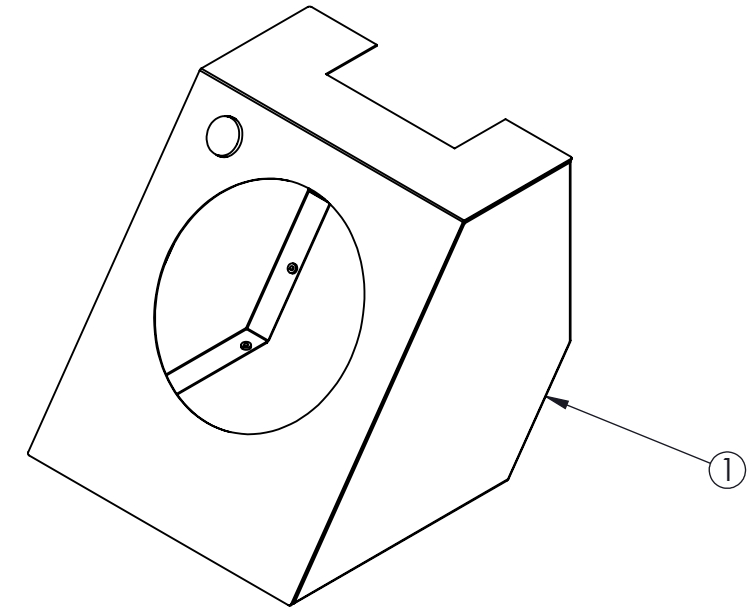
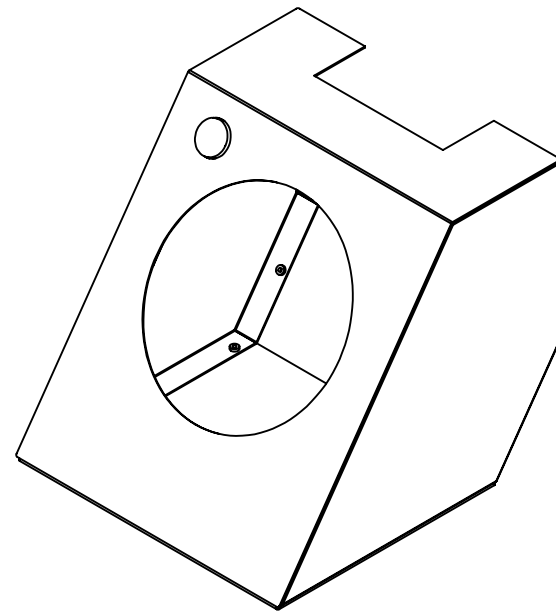
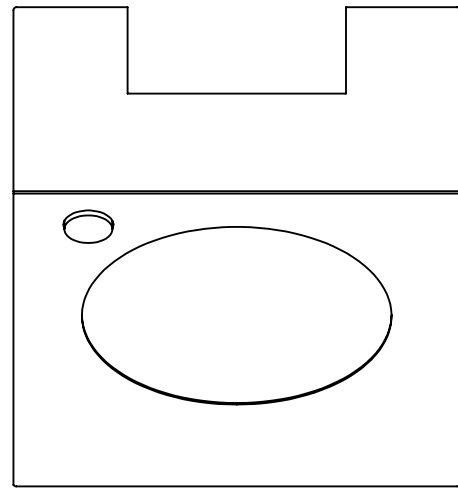

ITEM NO.	PART NUMBER	DESCRIPTION	QTY.
1	Assem19	MAIN BODY SUBASSEMBLY	1
2	Part14	BOTTOM COVER	1
3	P12897	RUBBER FEET 3/4" DIAMETER X 3/8" BLACK 741 RW	4
4	P26521	MACHINE SCREW 8-32 X 3/8 PHILLIP PAN HEAD BLACK OXIDE	4

TOLERANCES UNLESS OTHERWISE NOTED XXX ± .015 XX ± .030 HOLE ± .005 ANGLE ± 1°		 AMD Industries Inc. 4620 West 19th Street, Cicero, IL 60804	
DESIGNED JB		TITLE <b>MAIN BODY ASSEMBLY</b>	
DATE 12/07/17		MATERIAL N/A	
DATE 12/20/17		PART NO PXXXXX	
		FINISH XXXXXXXXXXXX	
		SHEET 1 OF 1	

REV	ECN #	DESCRIPTION	DATE	BY
1	XXX	DESIGN INTENT FOR ENGINEERING	12/20/17	JB

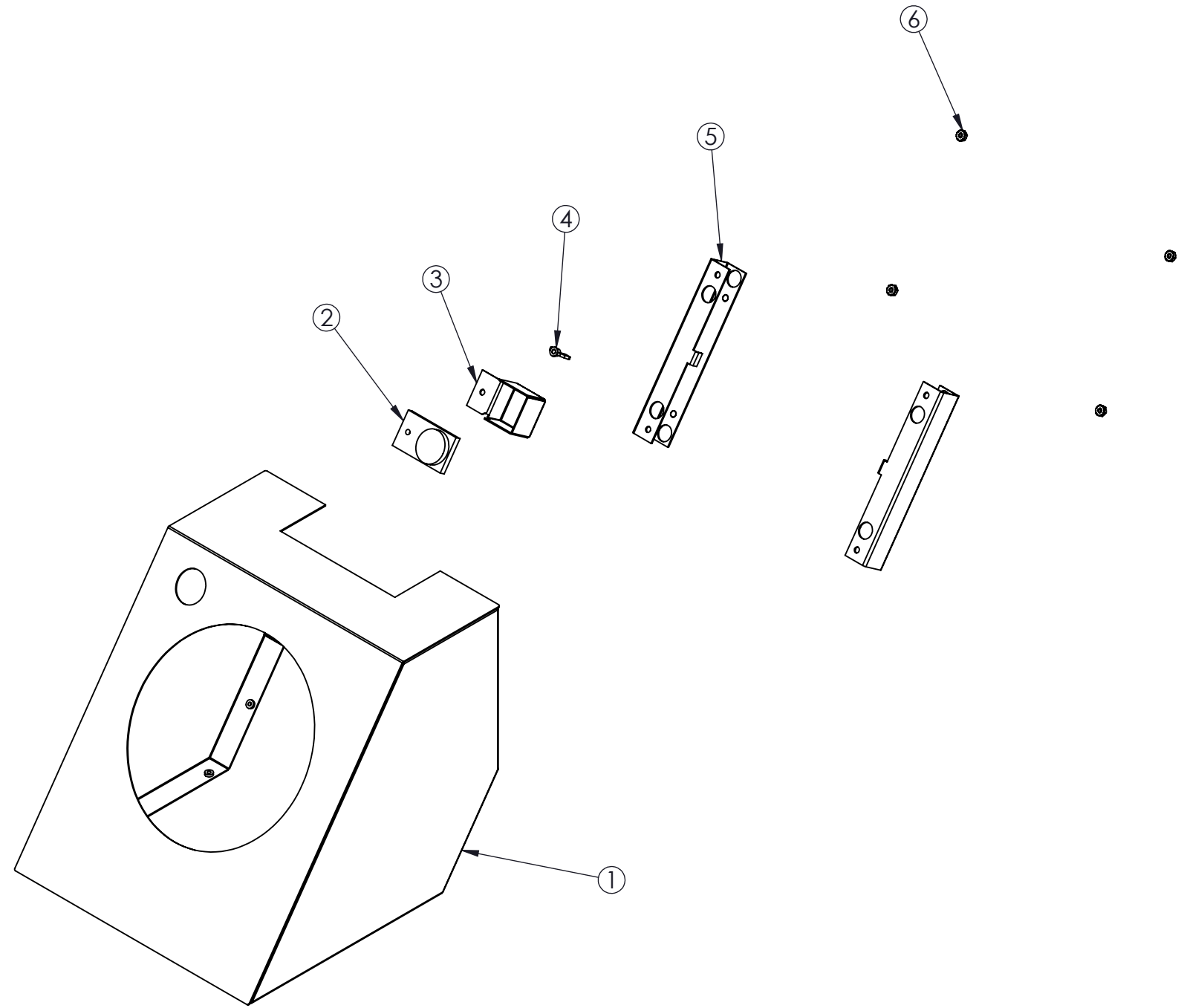
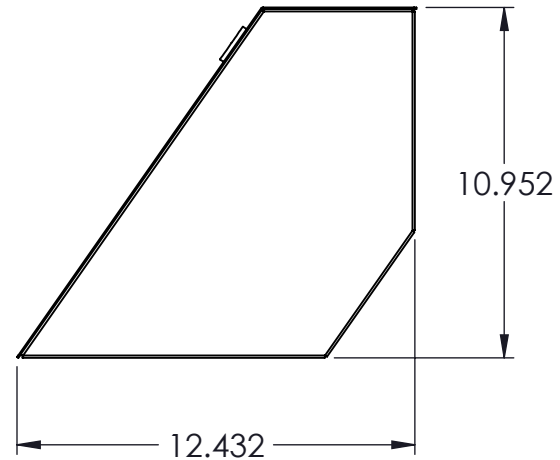
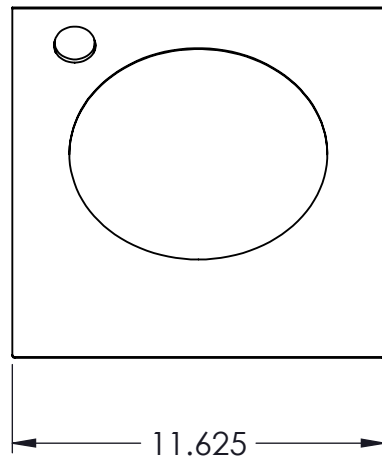
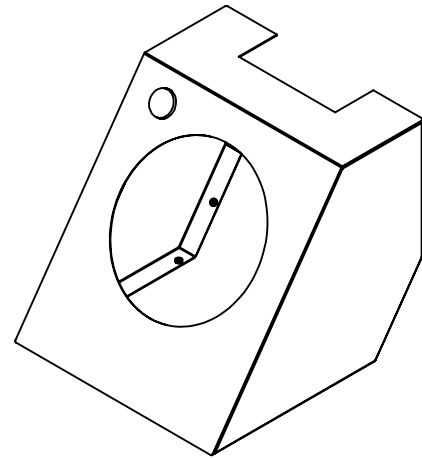
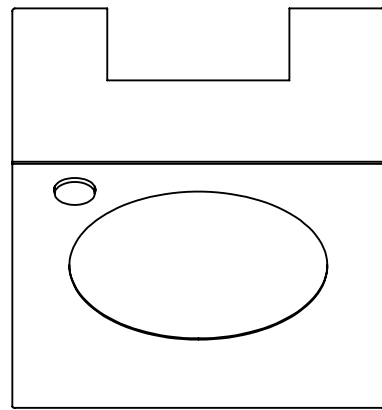

ITEM NO.	PART NUMBER	DESCRIPTION	QTY.
1	Assem12	MAIN BODY WELDMENT	1
2	Assem13	BACKLIT DIMENSIONAL GRAPHIC	1
3	Part17	LED LIGHT BOX	1
4	P10127	WING NUT 8-32 ZINC	1
5	Assem24	BRACKET ASSEMBLY	2
6	P11254	KEP NUT 8-32 ZINC	4

TOLERANCES UNLESS OTHERWISE NOTED XXX ± .015 XX ± .030 HOLE ± .005 ANGLE ± 1°	 AMD Industries Inc. 4620 West 19th Street, Cicero, IL 60804		PART NO PXXXXX
	TITLE MAIN BODY SUBASSEMBLY		
DESIGNED JB	DRAWN JB	MATERIAL N/A	SHEET 1 OF 1
DATE 12/07/17	DATE 12/20/17	FINISH XXXXXXXXXX	

REV	ECN #	DESCRIPTION	DATE	BY
1	XXX	DESIGN INTENT FOR ENGINEERING	12/20/17	JB

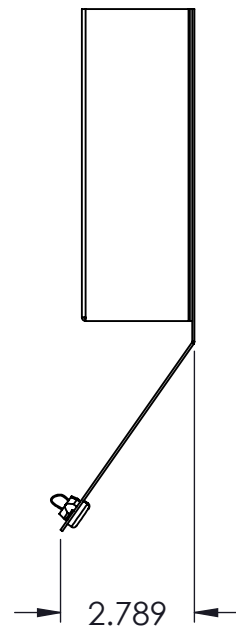
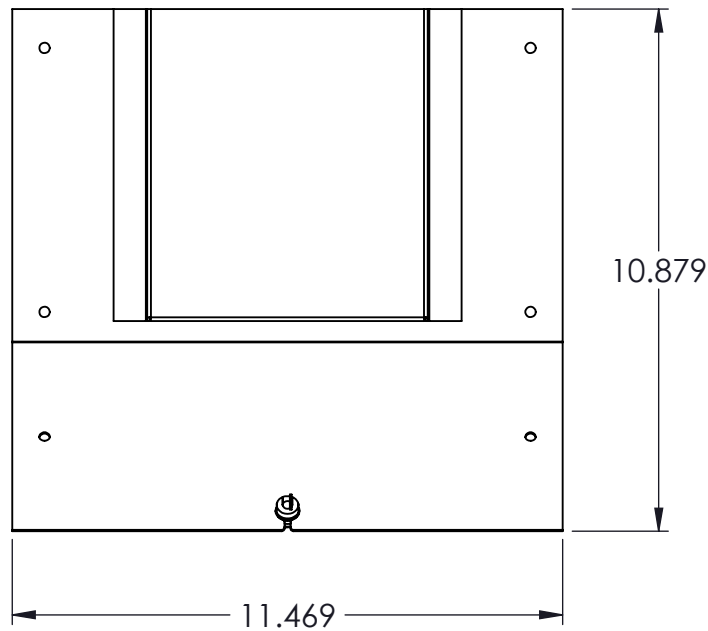
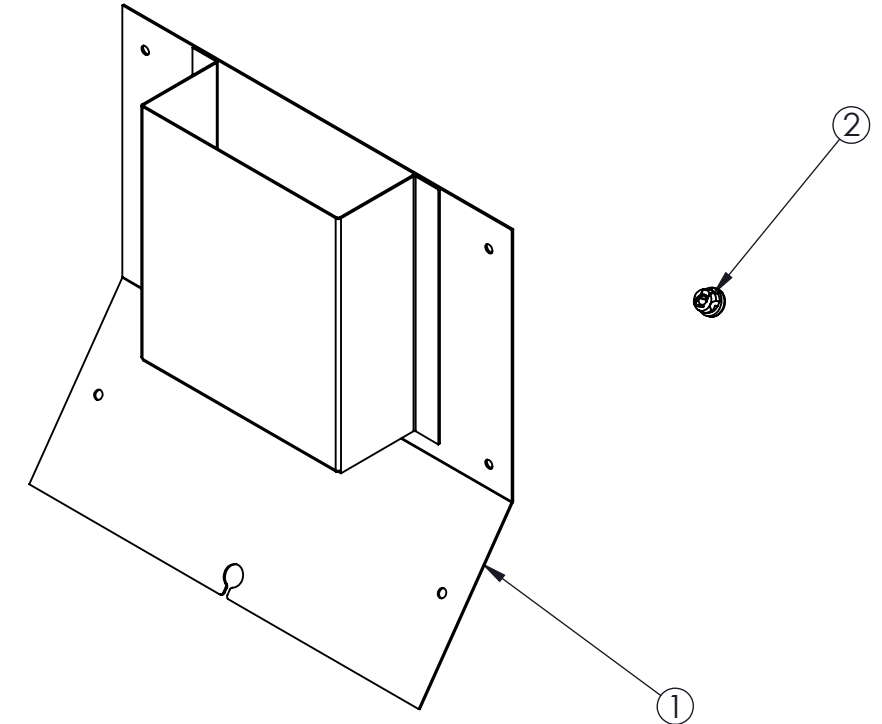
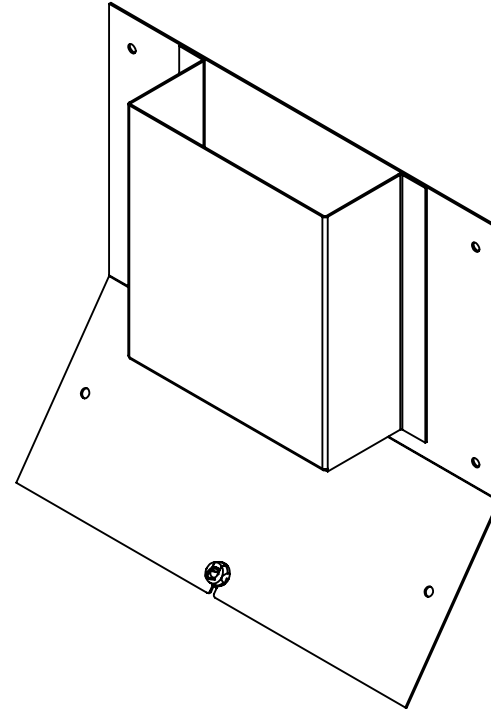
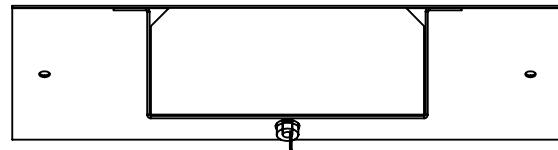

ITEM NO.	PART NUMBER	DESCRIPTION	QTY.
1	Assem18	BACK COVER WELDMENT	1
2	74125K710_SNAP-IN CORD GRIP (1)	SNAP-IN PLASTIC CORD GRIP - MCMaster-CARR #74125K71	1

TOLERANCES UNLESS OTHERWISE NOTED XXX ± .015 XX ± .030 HOLE ± .005 ANGLE ± 1°	 <b>AMD Industries Inc.</b> 4620 West 19th Street, Cicero, IL 60804		
	<b>TITLE</b> BACK COVER ASSEMBLY		
DESIGNED JB	DRAWN JB	MATERIAL N/A	PART NO PXXXXX
DATE 12/10/17	DATE 12/20/17	FINISH XXXXXXXXXX	SHEET 1 OF 1

REV	ECN #	DESCRIPTION	DATE	BY
1	XXX	DESIGN INTENT FOR ENGINEERING	12/20/17	JB

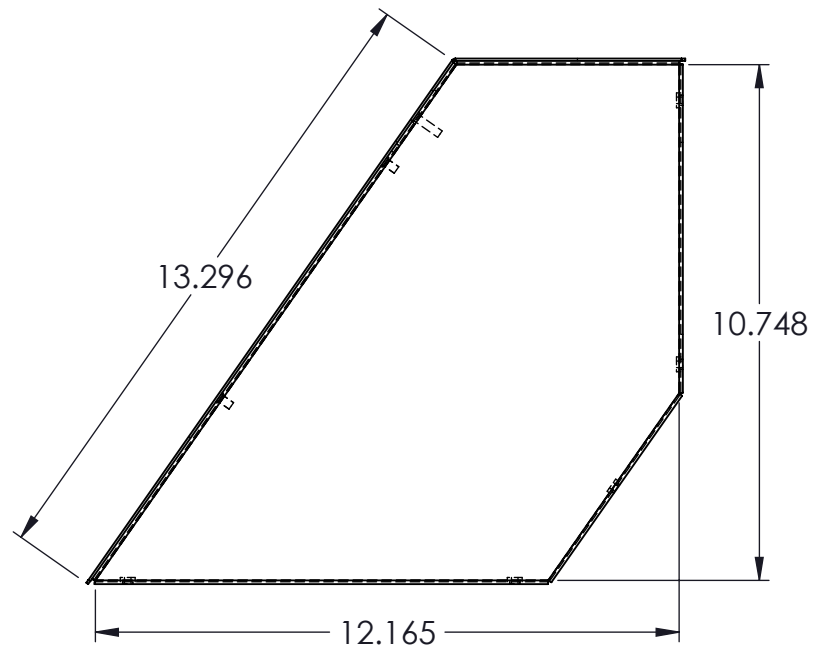
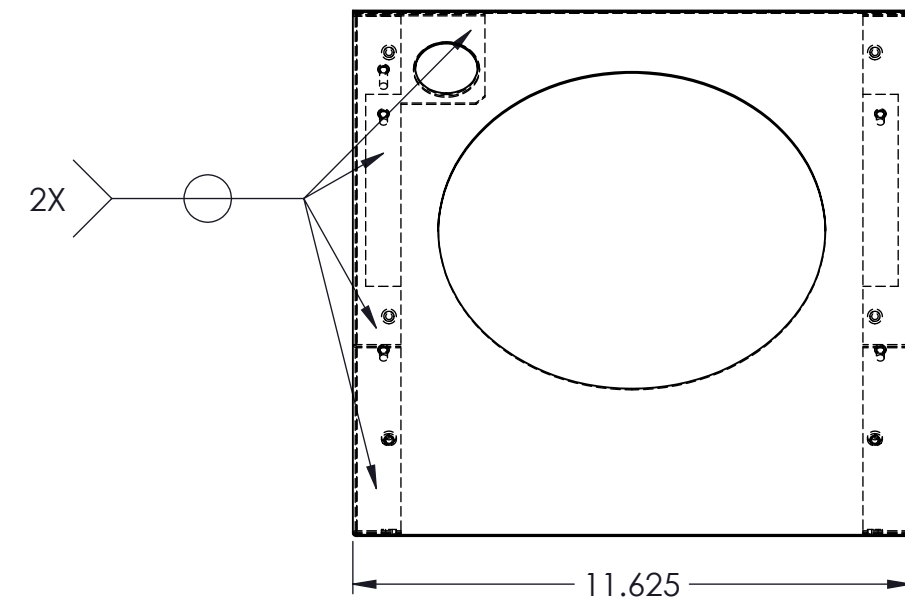
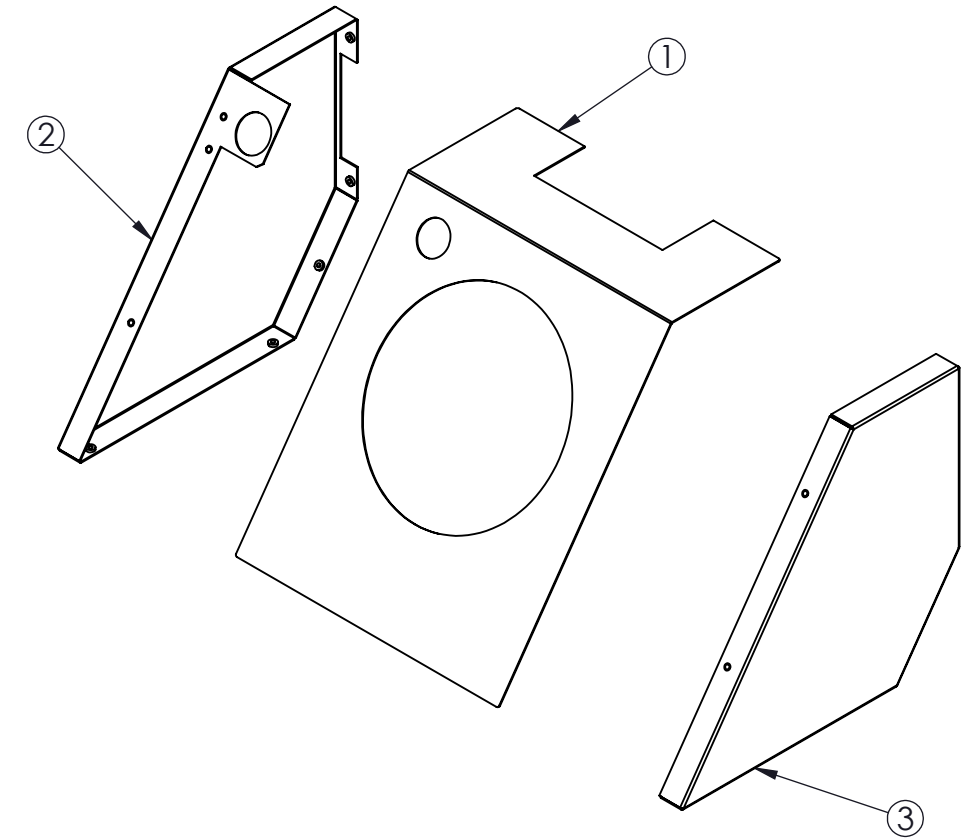
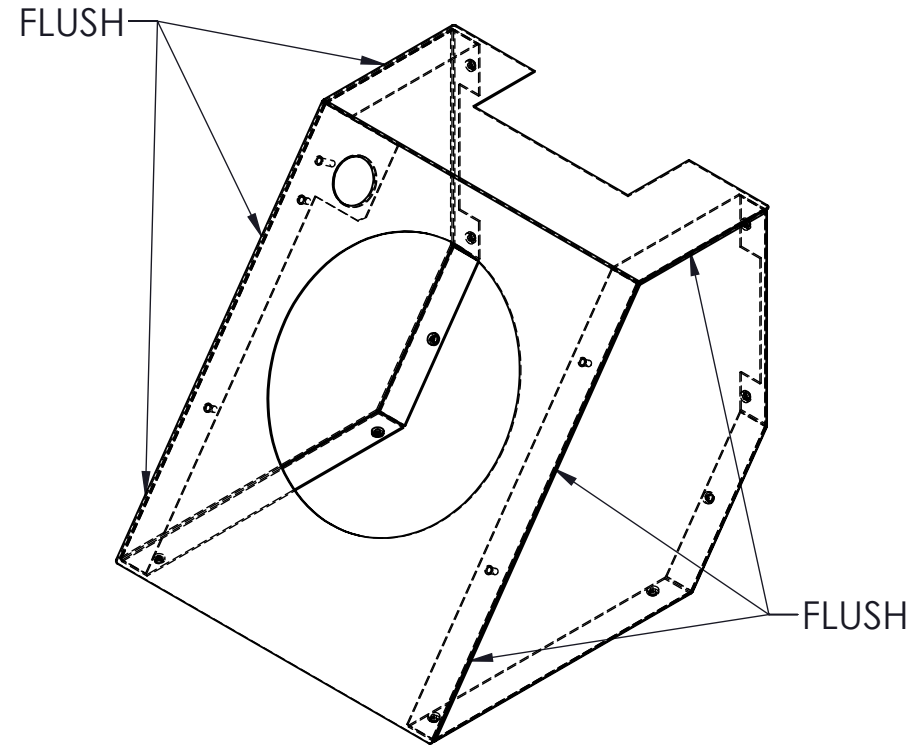
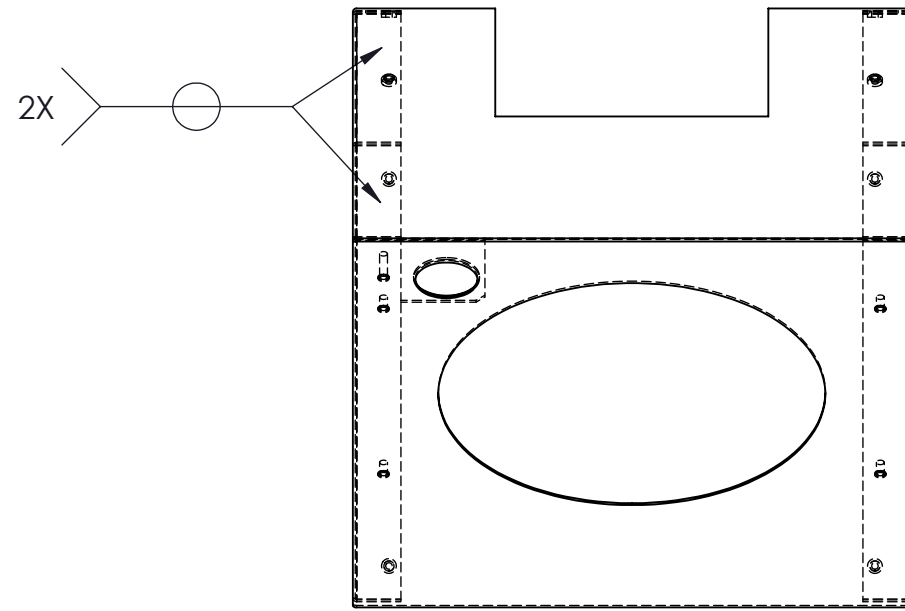

NOTES:  
SEE NEXT PAGE FOR INK  
TRANSFER DIRECTION

ITEM NO.	PART NUMBER	DESCRIPTION	QTY.
1	Part1a	FRONT	1
2	Assem16	SIDE RIGHT SUBASSEMBLY	1
3	Assem17	SIDE LEFT SUBASSEMBLY	1

TOLERANCES UNLESS OTHERWISE NOTED XXX ± .015 XX ± .030 HOLE ± .005 ANGLE ± 1°		 AMD Industries Inc. 4620 West 19th Street, Cicero, IL 60804	
TITLE MAIN BODY WELDMENT			
DESIGNED JB	DRAWN JB	MATERIAL N/A	PART NO PXXXXX
DATE 12/10/17	DATE 12/20/17	FINISH BLACK MINI TEX	SHEET 1 OF 2



REV	ECN #	DESCRIPTION	DATE	BY
1	XXXX	FOR PRICING	01/02/18	JB

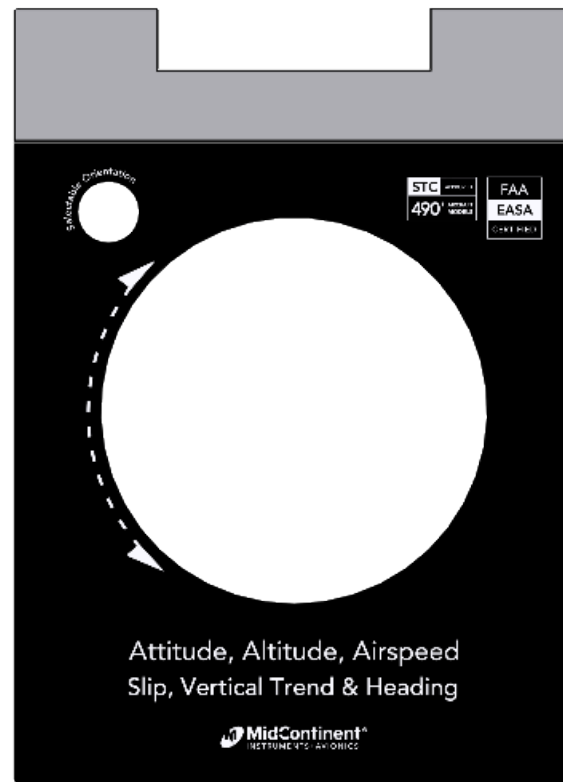

FRONT ANGLED SURFACE

NOTES:

- APPLY 3 INK TRANSFERS ON 3 DIFFERENT PLANAR SURFACES AFTER PAINTING
- USE PROVIDED ARTWORK
- 2 ARE 2 COLOR INK TRANSFER; WHITE AND BLUE
- 1 IS 1 COLOR INK TRANSFER; WHITE ONLY
- STANDARD DURATAG WITH BLEND 21 ACTIVATOR TO ADHERE TO BLACK MINI TEX POWDERCOATED METAL



LEFT SIDE



RIGHT SIDE

TOLERANCES UNLESS OTHERWISE NOTED XXX ± .015 XX ± .030 HOLE ± .005 ANGLE ± 1°	 AMD Industries Inc. 4620 West 19th Street, Cicero, IL 60804		PART NO PXXXXX
	TITLE MAIN BODY WELDMENT		
DESIGNED JB	DRAWN JB	MATERIAL N/A	SHEET 2 OF 2
DATE 12/10/17	DATE 12/20/17	FINISH BLACK MINI TEX	

REV	ECN #	DESCRIPTION	DATE	BY
1	XXX	DESIGN INTENT FOR ENGINEERING	12/20/17	JB

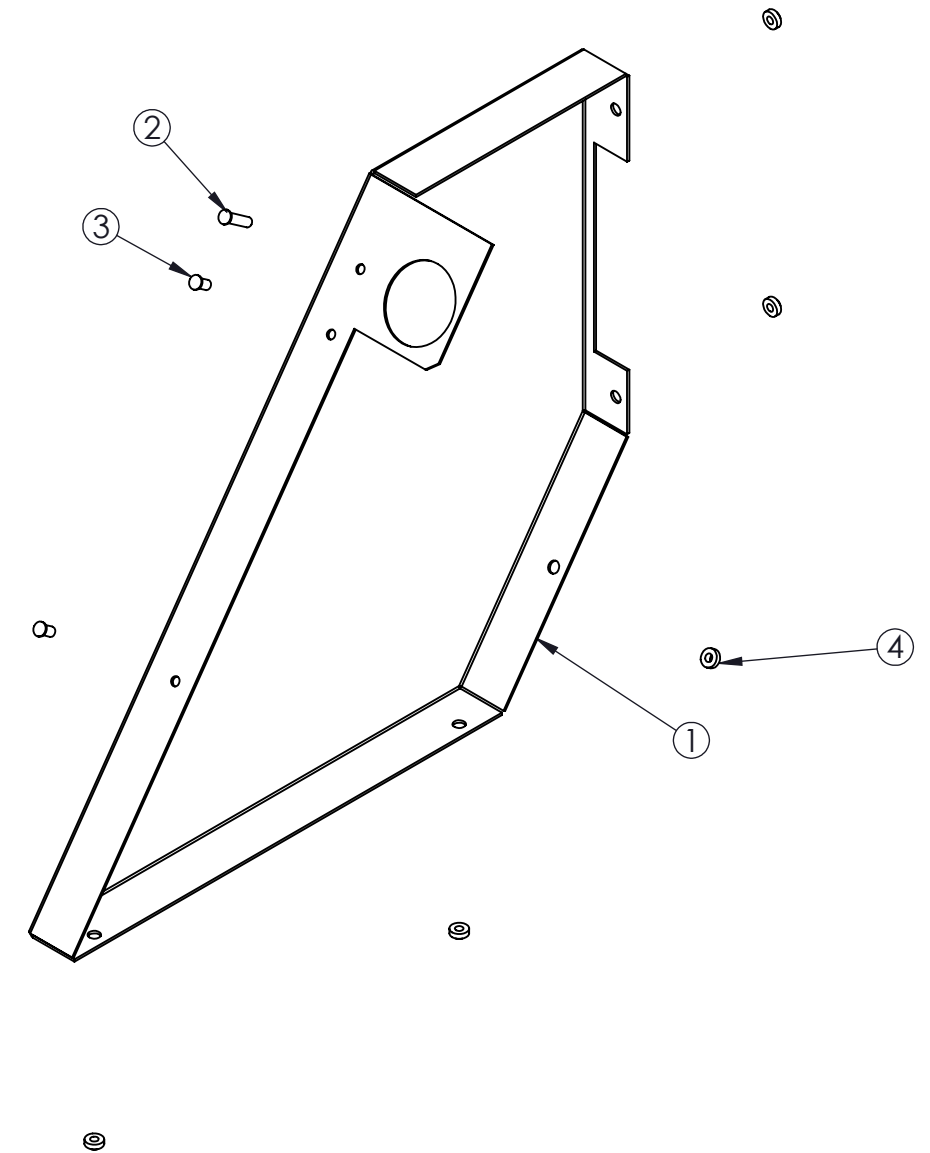
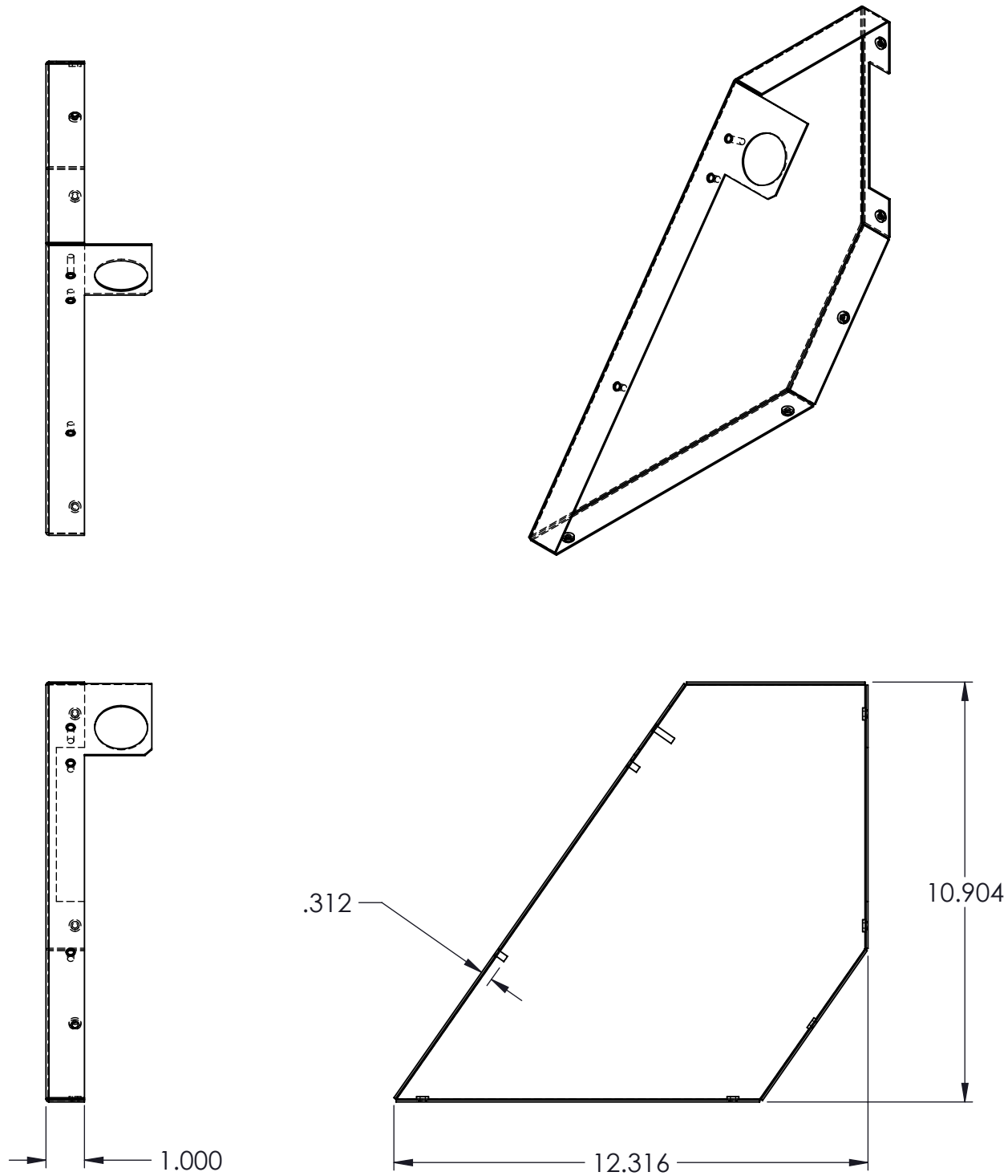

ITEM NO.	PART NUMBER	DESCRIPTION	QTY.
1	Part20	SIDE LEFT	1
2	P62476	PEM STUD SELF CLINCH FLUSH 8-32 X 5/8" #FH-832-10 ZI	1
3	P36073	PEM STUD SELF CLINCH FLUSH 8-32 X 5/16" #FH-832-5 ZI	2
4	P33383	PEM NUT SELF CLINCH 8-32 X .038" PEM #S-832-1ZI	5

TOLERANCES UNLESS OTHERWISE NOTED XXX ± .015 XX ± .030 HOLE ± .005 ANGLE ± 1°		 AMD Industries Inc. 4620 West 19th Street, Cicero, IL 60804	
DESIGNED JB		DRAWN JB	
DATE 12/07/17		DATE 12/20/17	
TITLE SIDE RIGHT SUBASSEMBLY		MATERIAL N/A	
		PART NO PXXXXX	
		FINISH XXXXXXXXXX	
		SHEET 1 OF 1	

REV	ECN #	DESCRIPTION	DATE	BY
1	XXX	DESIGN INTENT FOR ENGINEERING	12/20/17	JB

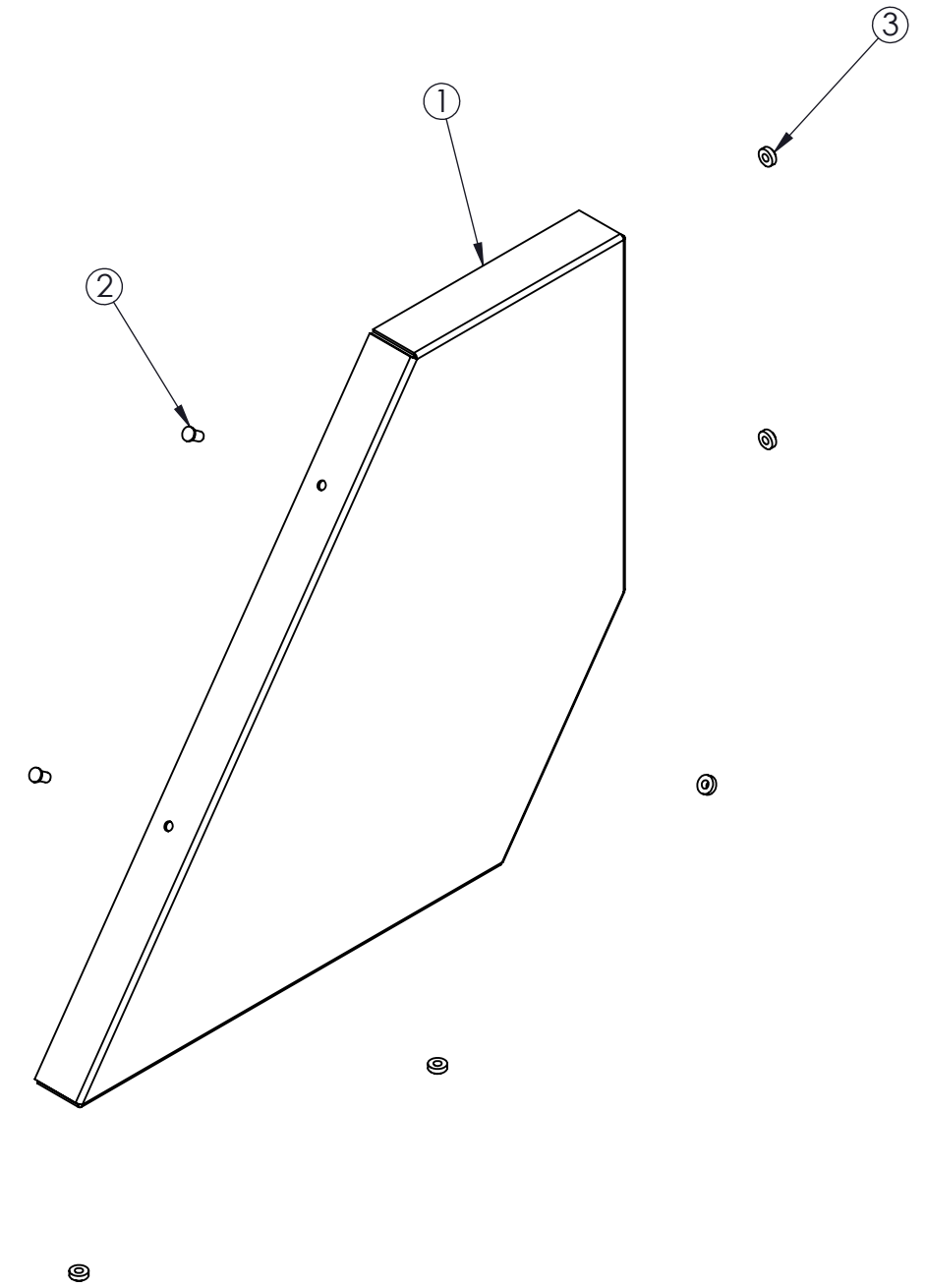
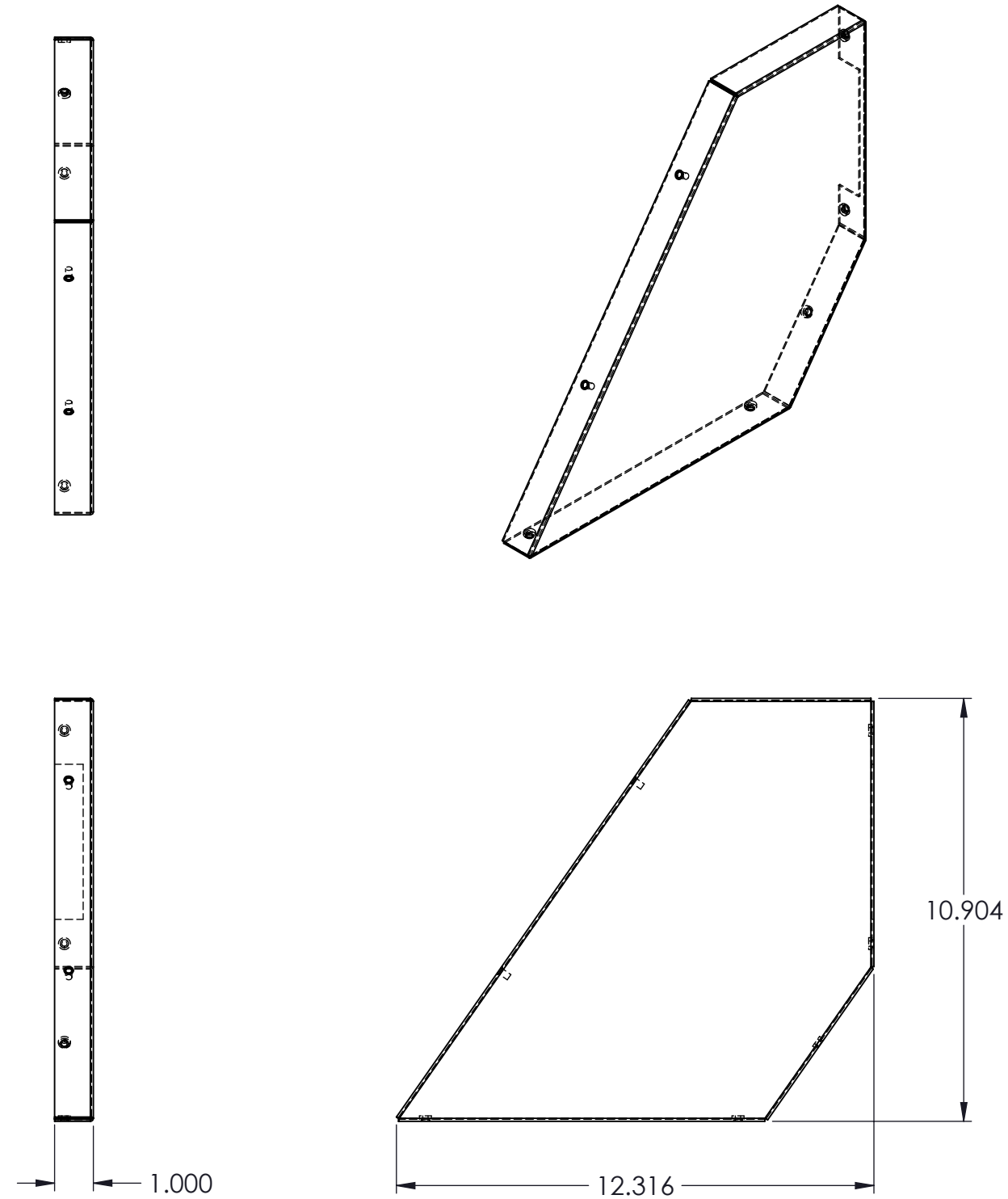

ITEM NO.	PART NUMBER	DESCRIPTION	QTY.
1	Part21	SIDE RIGHT	1
2	P36073	PEM STUD SELF CLINCH FLUSH 8-32 X 5/16" #FH-832-5 ZI	2
3	P33383	PEM NUT SELF CLINCH 8-32 X .038" PEM #S-832-1ZI	5

TOLERANCES UNLESS OTHERWISE NOTED XXX ± .015 XX ± .030 HOLE ± .005 ANGLE ± 1°		 AMD Industries Inc. 4620 West 19th Street, Cicero, IL 60804	
DESIGNED JB		TITLE SIDE LEFT SUBASSEMBLY	
DATE 12/07/17		PART NO PXXXXX	
DRAWN JB		MATERIAL N/A	
DATE 12/20/17		FINISH XXXXXXXXXX	
		SHEET 1 OF 1	

REV	ECN #	DESCRIPTION	DATE	BY
1	XXX	DESIGN INTENT FOR ENGINEERING	12/20/17	JB

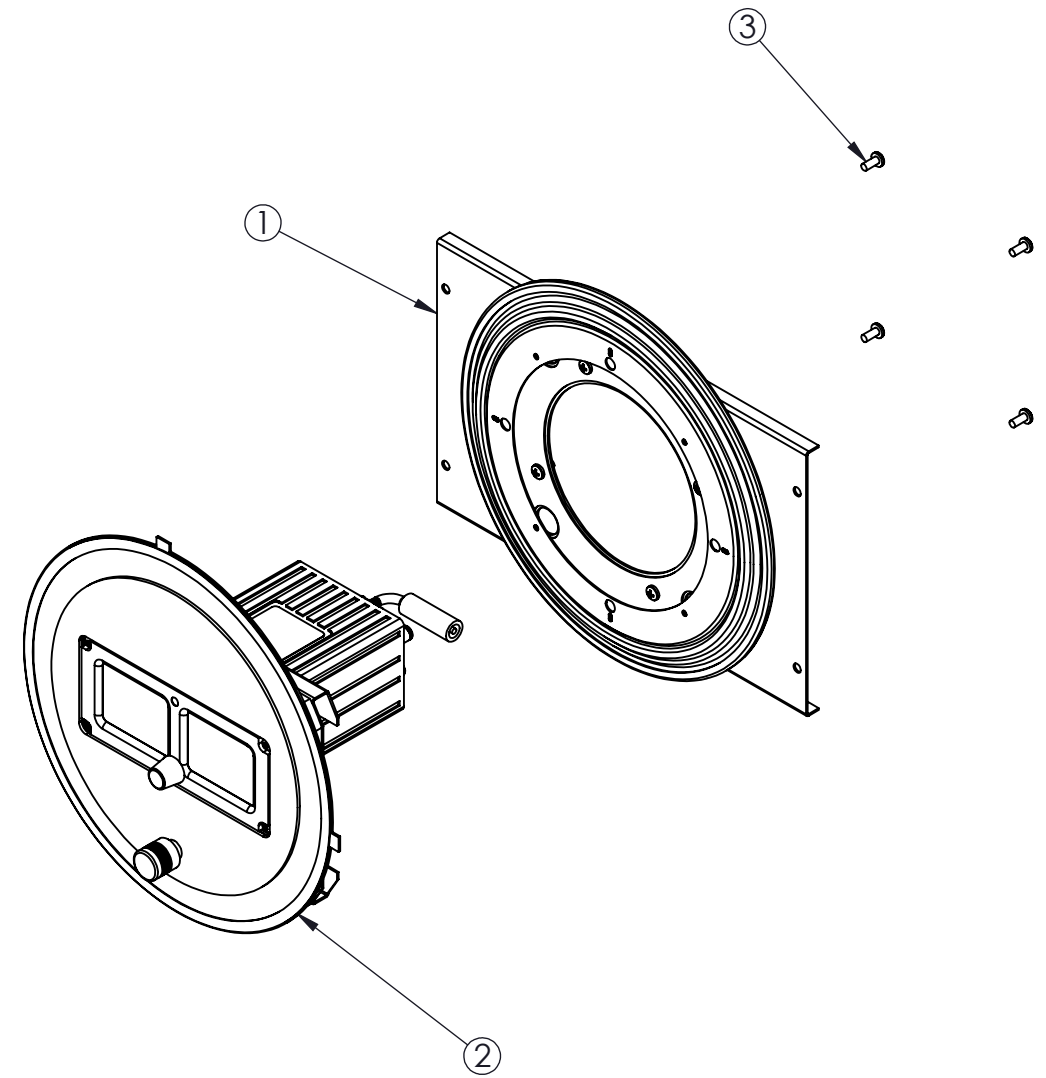
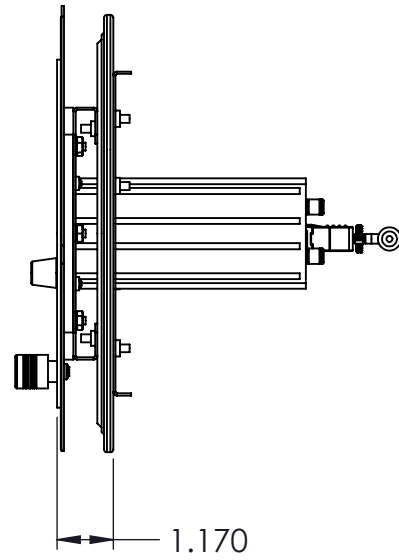
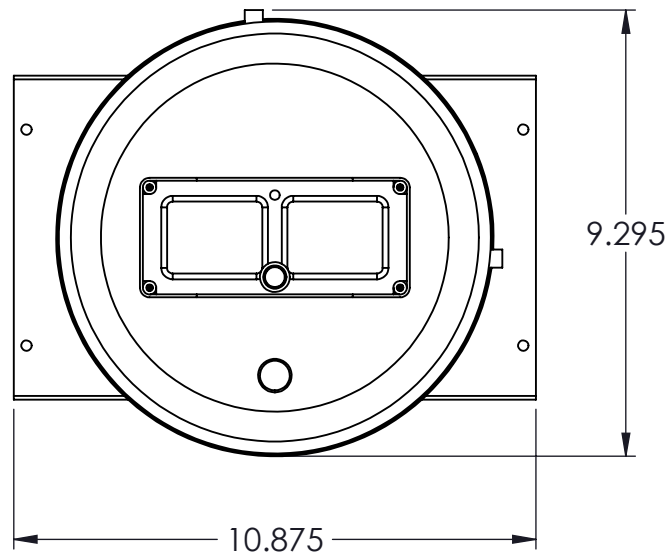
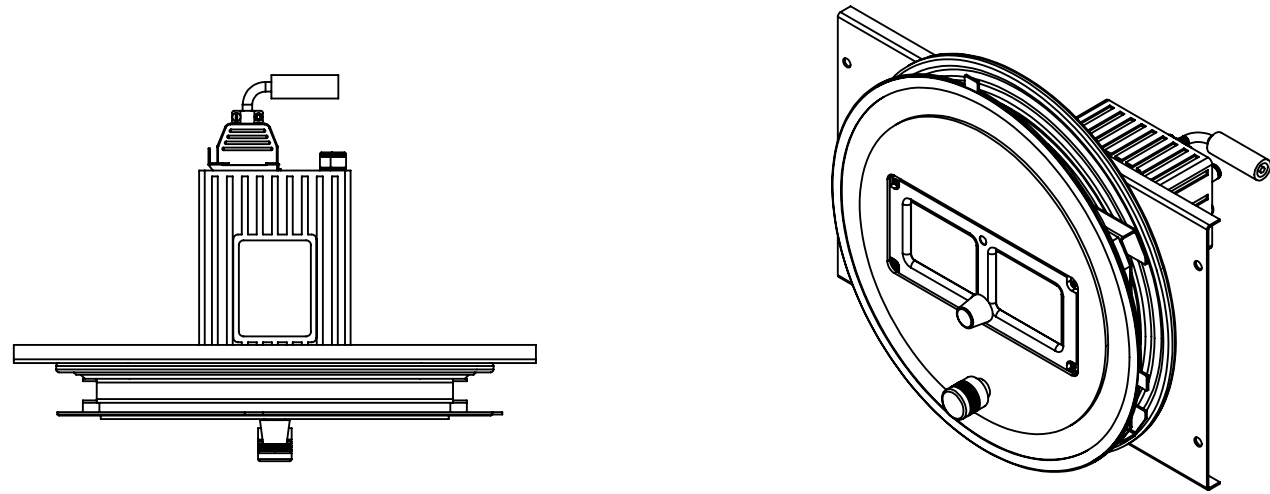

ITEM NO.	PART NUMBER	DESCRIPTION	QTY.
1	Assem8	ROTATING SUBASSEMBLY	1
2	Assem3	SAM ROTATING ASSEMBLY	1
3	P19709	MACHINE SCREW 8-32 X 3/8 PHILLIP PAN HEAD ZINC	4

TOLERANCES UNLESS OTHERWISE NOTED XXX ± .015 XX ± .030 HOLE ± .005 ANGLE ± 1°		 AMD Industries Inc. 4620 West 19th Street, Cicero, IL 60804	
DESIGNED JB		TITLE ROTATING ASSEMBLY	
DATE 12/11/17	DRAWN JB	MATERIAL N/A	PART NO PXXXXX
	DATE 12/20/17	FINISH XXXXXXXXXX	SHEET 1 OF 1

REV	ECN #	DESCRIPTION	DATE	BY
1	XXX	DESIGN INTENT FOR ENGINEERING	12/20/17	JB

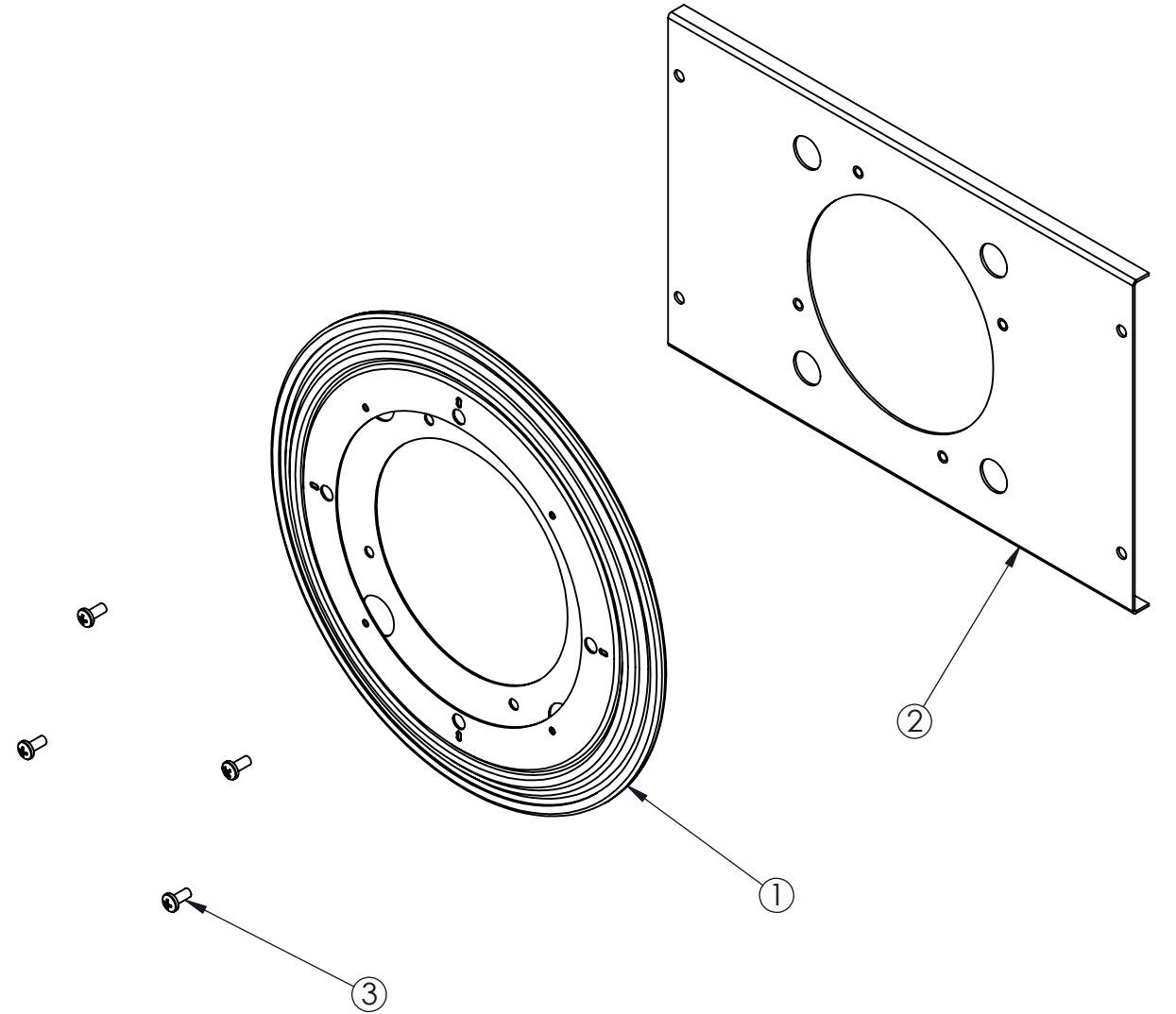
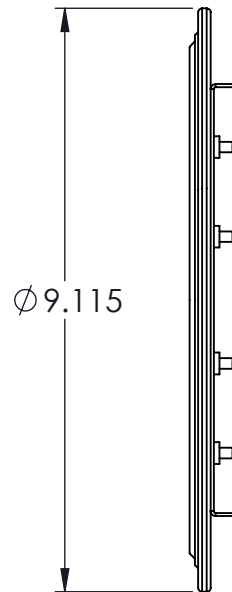
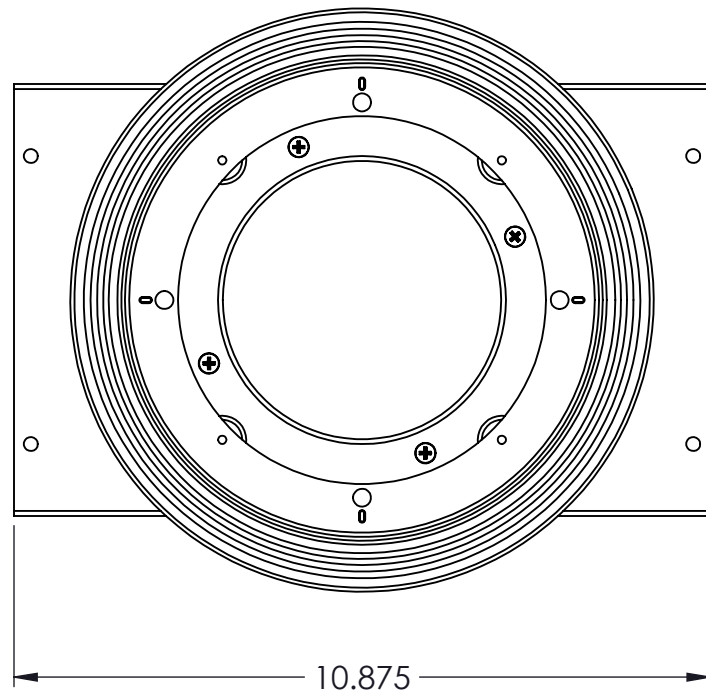
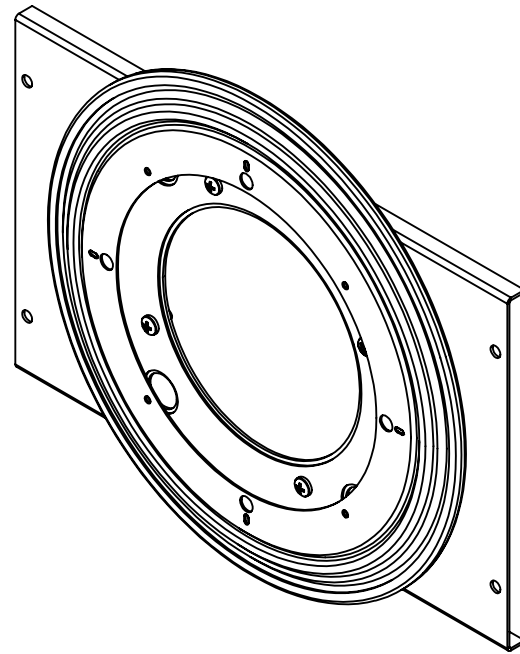
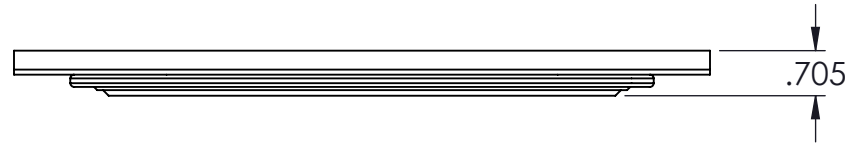

ITEM NO.	PART NUMBER	DESCRIPTION	QTY.
1	Assem7	TURNTABLE ASSEMBLY MCMMASTER #1797K210	1
2	Assem14	FIXED TURNTABLE BRACKET SUBASSEMBLY	1
3	P19709	MACHINE SCREW 8-32 X 3/8 PHILLIP PAN HEAD ZINC	4

TOLERANCES UNLESS OTHERWISE NOTED XXX ± .015 XX ± .030 HOLE ± .005 ANGLE ± 1°		 AMD Industries Inc. 4620 West 19th Street, Cicero, IL 60804	
TITLE ROTATING SUBASSEMBLY			
DESIGNED JB	DRAWN JB	MATERIAL N/A	PART NO PXXXXX
DATE 12/07/17	DATE 12/20/17	FINISH XXXXXXXXXX	SHEET 1 OF 1

REV	ECN #	DESCRIPTION	DATE	BY
1	XXX	DESIGN INTENT FOR ENGINEERING	12/20/17	JB

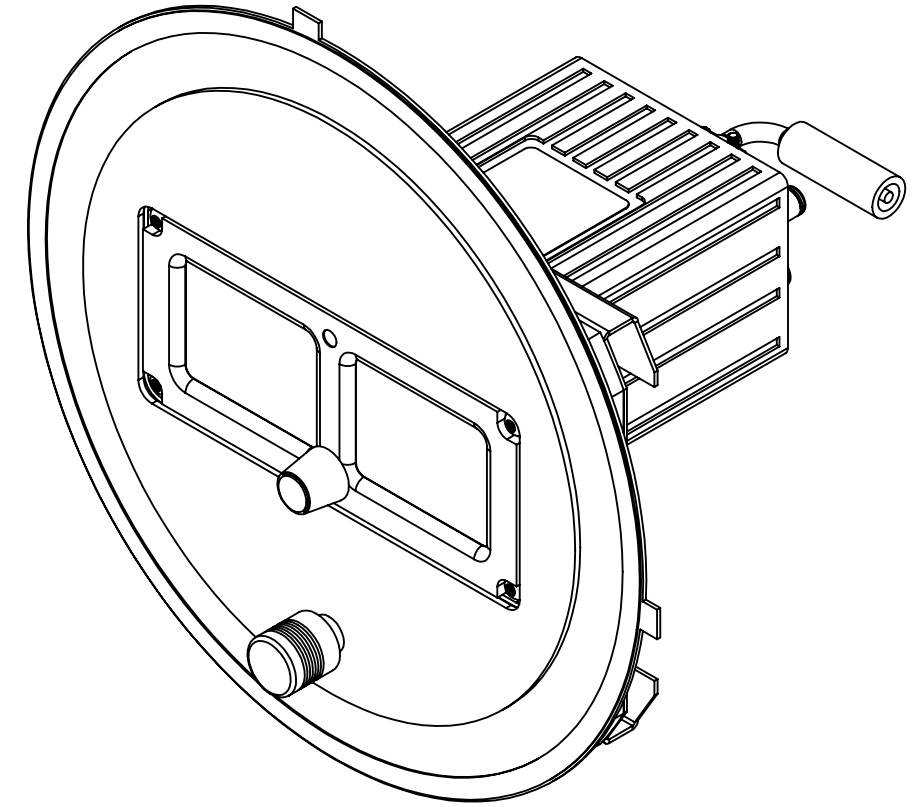
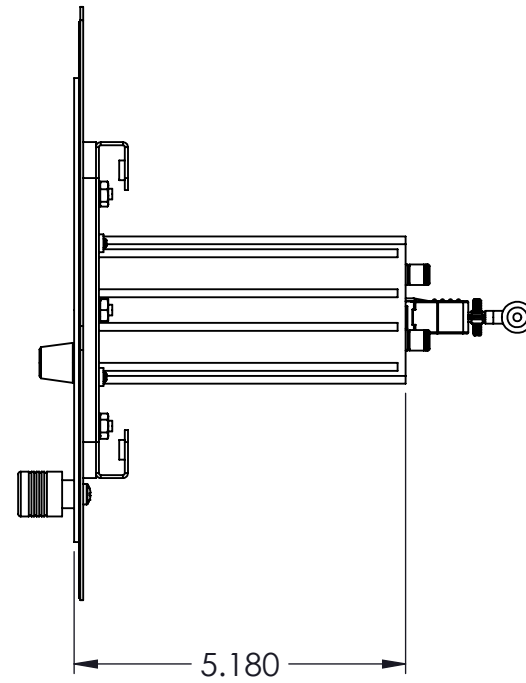
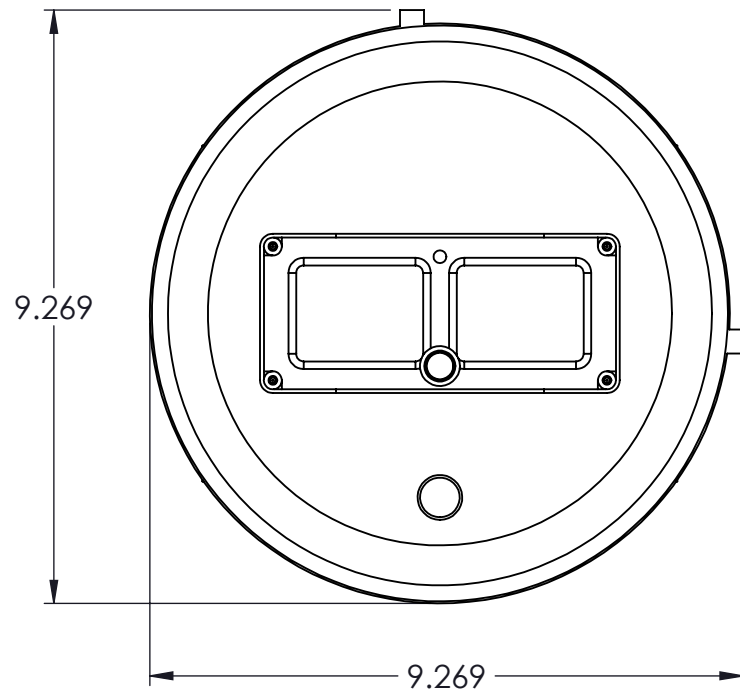
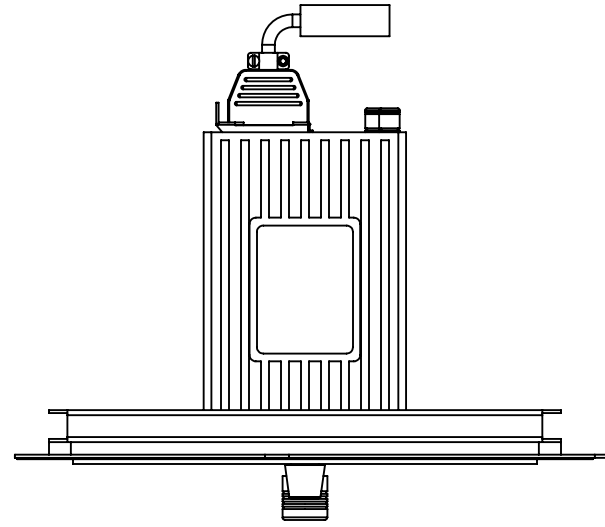

TOLERANCES UNLESS OTHERWISE NOTED XXX ± .015 XX ± .030 HOLE ± .005 ANGLE ± 1°	 AMD Industries Inc. 4620 West 19th Street, Cicero, IL 60804		PART NO PXXXXX
	TITLE SAM ROTATING ASSEMBLY		
DESIGNED JB	DRAWN JB	MATERIAL N/A	SHEET 1 OF 2
DATE 12/07/17	DATE 12/20/17	FINISH XXXXXXXXXX	

REV	ECN #	DESCRIPTION	DATE	BY
1	XXX	DESIGN INTENT FOR ENGINEERING	12/20/17	JB

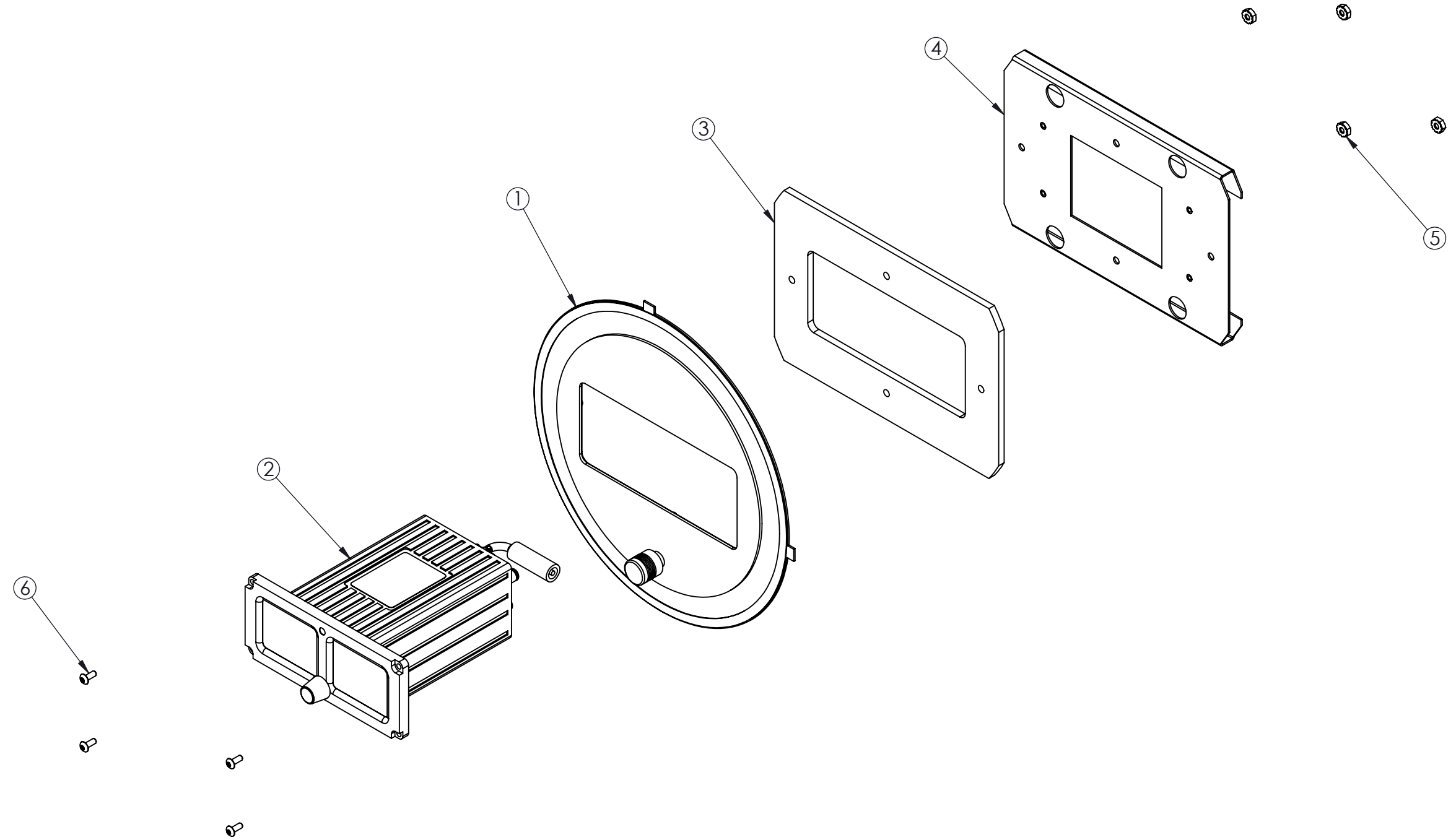

ITEM NO.	PART NUMBER	DESCRIPTION	QTY.
1	Assem9	SAM GRAPHIC ASSEMBLY WITH KNOB	1
2	SAM_ASSEMBLY	SAM ASSEMBLY (FBC)	1
3	Part10	SPACER	1
4	Assem6	TURNTABLE MOUNTING BRACKET SUBASSEMBLY	1
5	P11254	KEP NUT 8-32 ZINC	4
6	Default	MACHINE SCREW 6-32 X 3/8" TAMPER RESISTANT PIN-IN-TORX SOCKET BUTTON HEAD BLACK OXIDE	4

TOLERANCES UNLESS OTHERWISE NOTED XXX ± .015 XX ± .030 HOLE ± .005 ANGLE ± 1°		 AMD Industries Inc. 4620 West 19th Street, Cicero, IL 60804	
DESIGNED JB		TITLE <b>SAM ROTATING ASSEMBLY</b>	
DATE 12/07/17	DRAWN JB	MATERIAL N/A	PART NO PXXXXX
		FINISH XXXXXXXXXX	SHEET 2 OF 2

REV	ECN #	DESCRIPTION	DATE	BY
1	XXX	DESIGN INTENT FOR ENGINEERING	12/20/17	JB

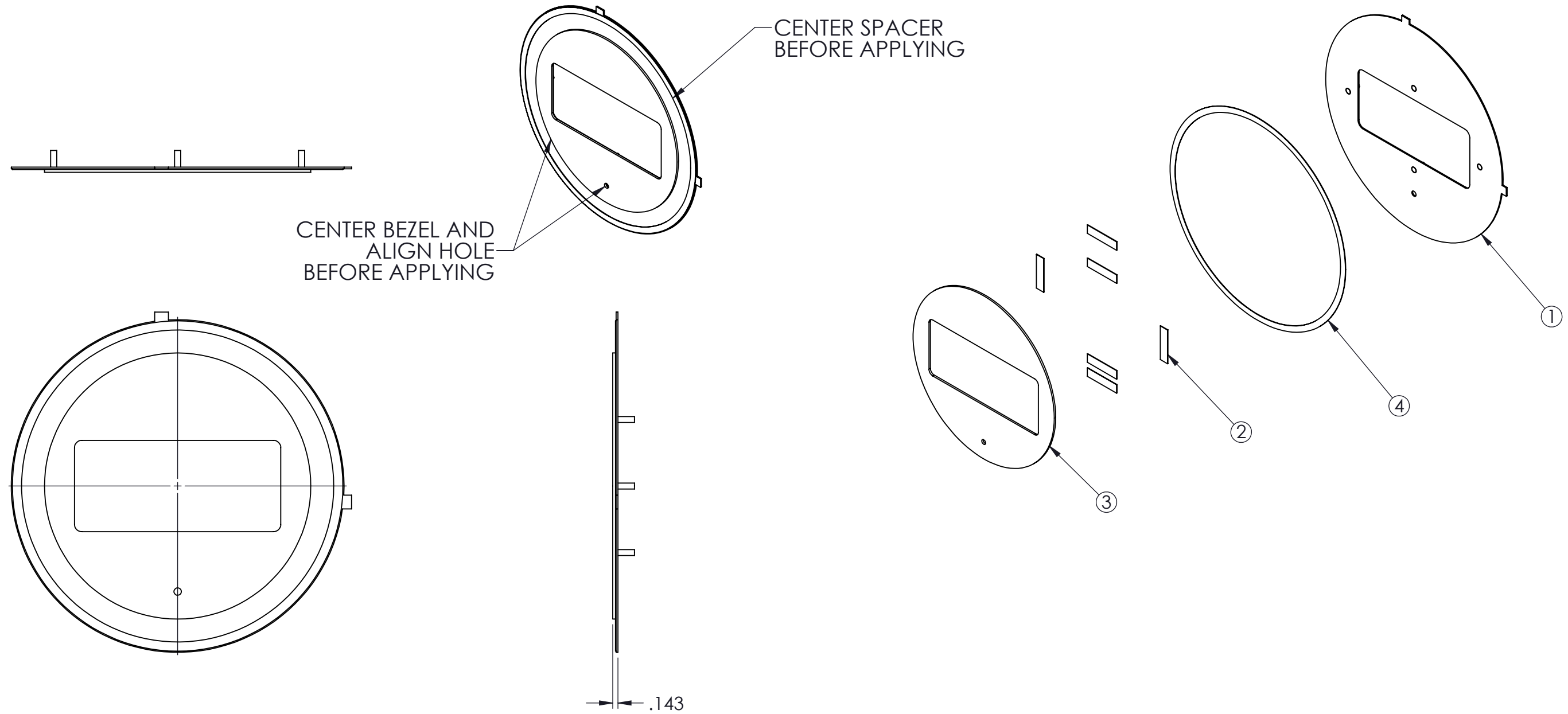

ITEM NO.	PART NUMBER	DESCRIPTION	QTY.
1	Assem4	ROTATING BRACKET WITH TABS SUBASSEMBLY	1
2	Part13	TWINSTICK 0.020" X 1.5" X .375"	6
3	Part4	SAM UNIT BEZEL	1
4	Part18	BLACK STYRENE WITH FULL BACK ADHESIVE	1

TOLERANCES UNLESS OTHERWISE NOTED XXX ± .015 XX ± .030 HOLE ± .005 ANGLE ± 1°		 AMD Industries Inc. 4620 West 19th Street, Cicero, IL 60804	
TITLE ROTATING BRACKET WITH TABS ASSEMBLY			
DESIGNED JB	DRAWN JB	MATERIAL N/A	PART NO PXXXXX
DATE 12/11/17	DATE 12/20/17	FINISH XXXXXXXXXX	SHEET 1 OF 1



REV	ECN #	DESCRIPTION	DATE	BY
1	XXX	DESIGN INTENT FOR ENGINEERING	12/20/17	JB

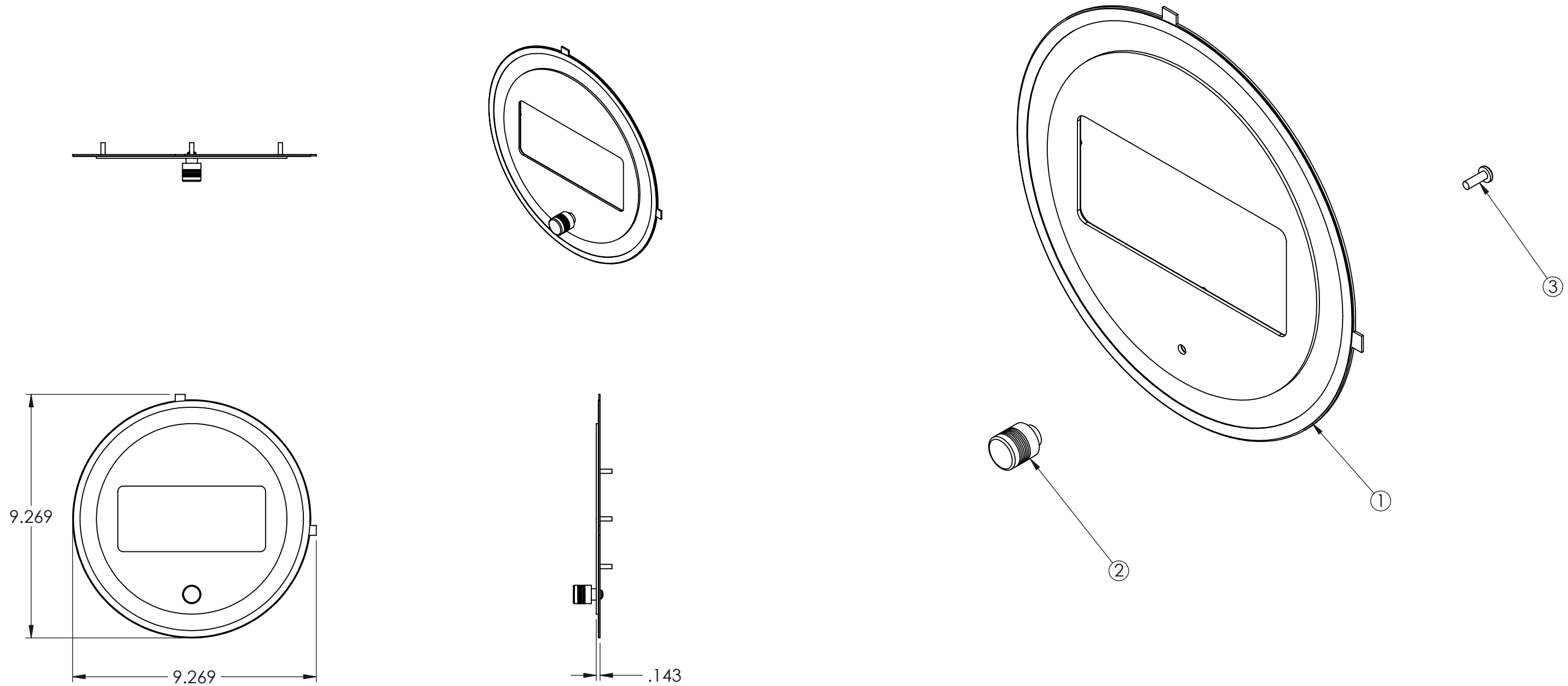

ITEM NO.	PART NUMBER	DESCRIPTION	QTY.
1	Assem5	ROTATING BRACKET WITH TABS ASSEMBLY	1
2	KNOB-16418-SS OUTWATER 304 SS 8-32X1 SCREW INCL	KNOB-16418-SS OUTWATER 304 SS 8-32X1 SCREW INCL	1
3	P13547	MACHINE SCREW 8-32 X 1/2 PHILLIP PAN HEAD BLACK OXIDE	1

TOLERANCES UNLESS OTHERWISE NOTED XXX ± .015 XX ± .030 HOLE ± .005 ANGLE ± 1°		 AMD Industries Inc. 4620 West 19th Street, Cicero, IL 60804	
TITLE SAM GRAPHIC ASSEMBLY WITH KNOB			
DESIGNED JB	DRAWN JB	MATERIAL N/A	PART NO PXXXXX
DATE 12/07/17	DATE 12/20/17	FINISH XXXXXXXXXX	SHEET 1 OF 1

REV	ECN #	DESCRIPTION	DATE	BY
1	XXX	DESIGN INTENT FOR ENGINEERING	12/20/17	JB

MASK ALL THREADS  
BEFORE PAINTING

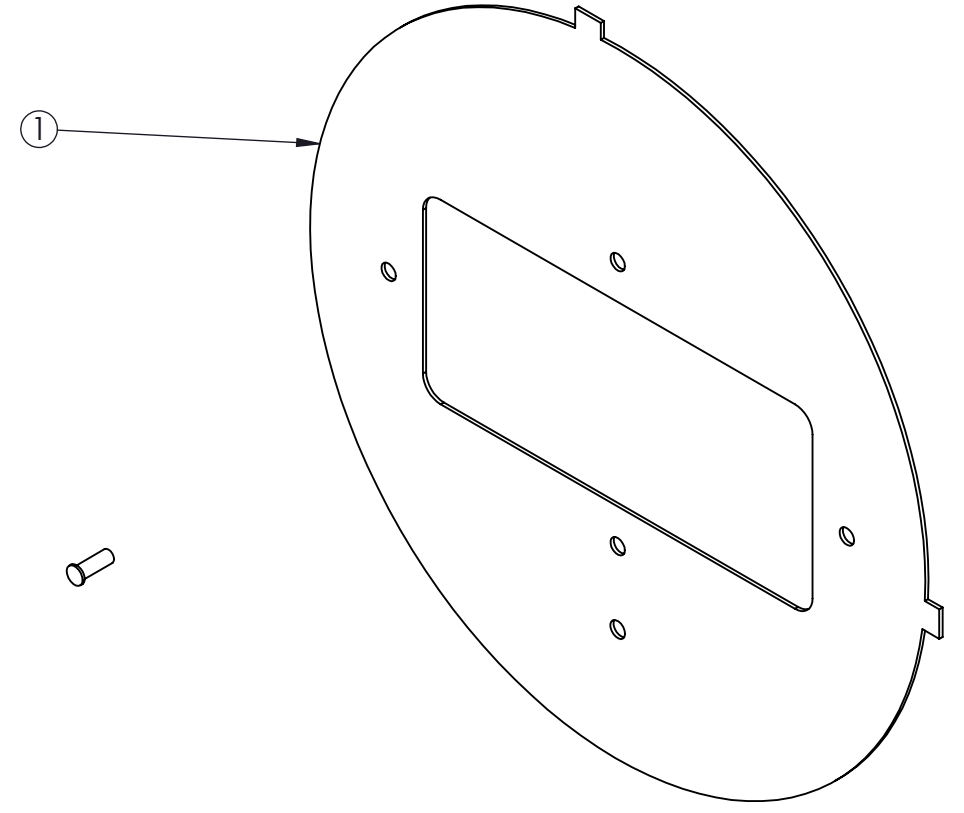
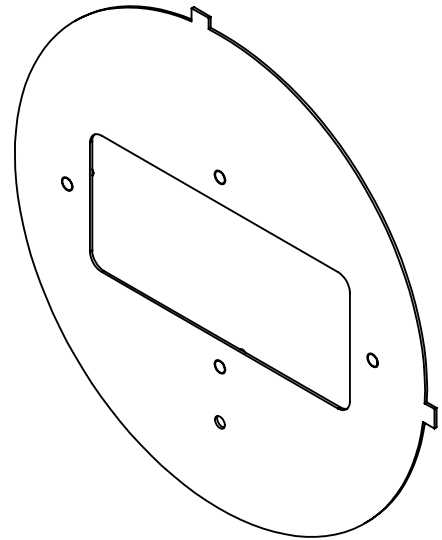

②

NOTE:  
SEE NEXT PAGE FOR INK  
TRANSFER DIRECTION

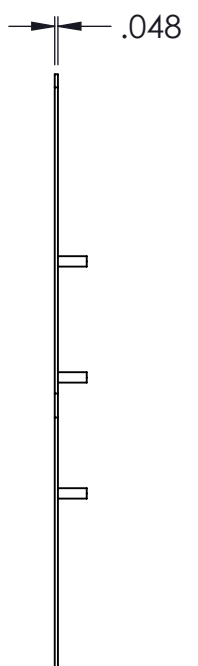
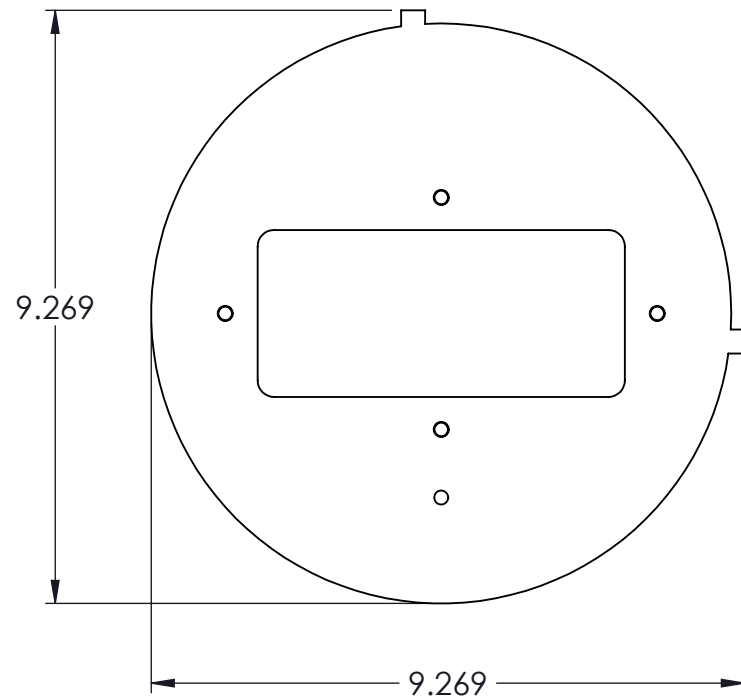

TOLERANCES  
UNLESS  
OTHERWISE NOTED  
XXX ± .015  
XX ± .030  
HOLE ± .005  
ANGLE ± 1°



AMD Industries Inc.  
4620 West 19th Street, Cicero, IL 60804

TITLE  
ROTATING BRACKET WITH TABS SUBASSEMBLY

DESIGNED	DRAWN	MATERIAL	PART NO
JB	JB	N/A	PXXXXX
DATE 12/13/17	DATE 12/20/17	FINISH BLACK MINI TEX	SHEET 1 OF 2

ITEM NO.	PART NUMBER	DESCRIPTION	QTY.
1	Part5	ROTATING BRACKET WITH TABS	1
2	P33752	PEM STUD SELF CLINCH FLUSH 8-32 X 1/2" #FH-832-8 ZI	4

REV	ECN #	DESCRIPTION	DATE	BY
1	XXX	DESIGN INTENT FOR ENGINEERING	12/20/17	JB

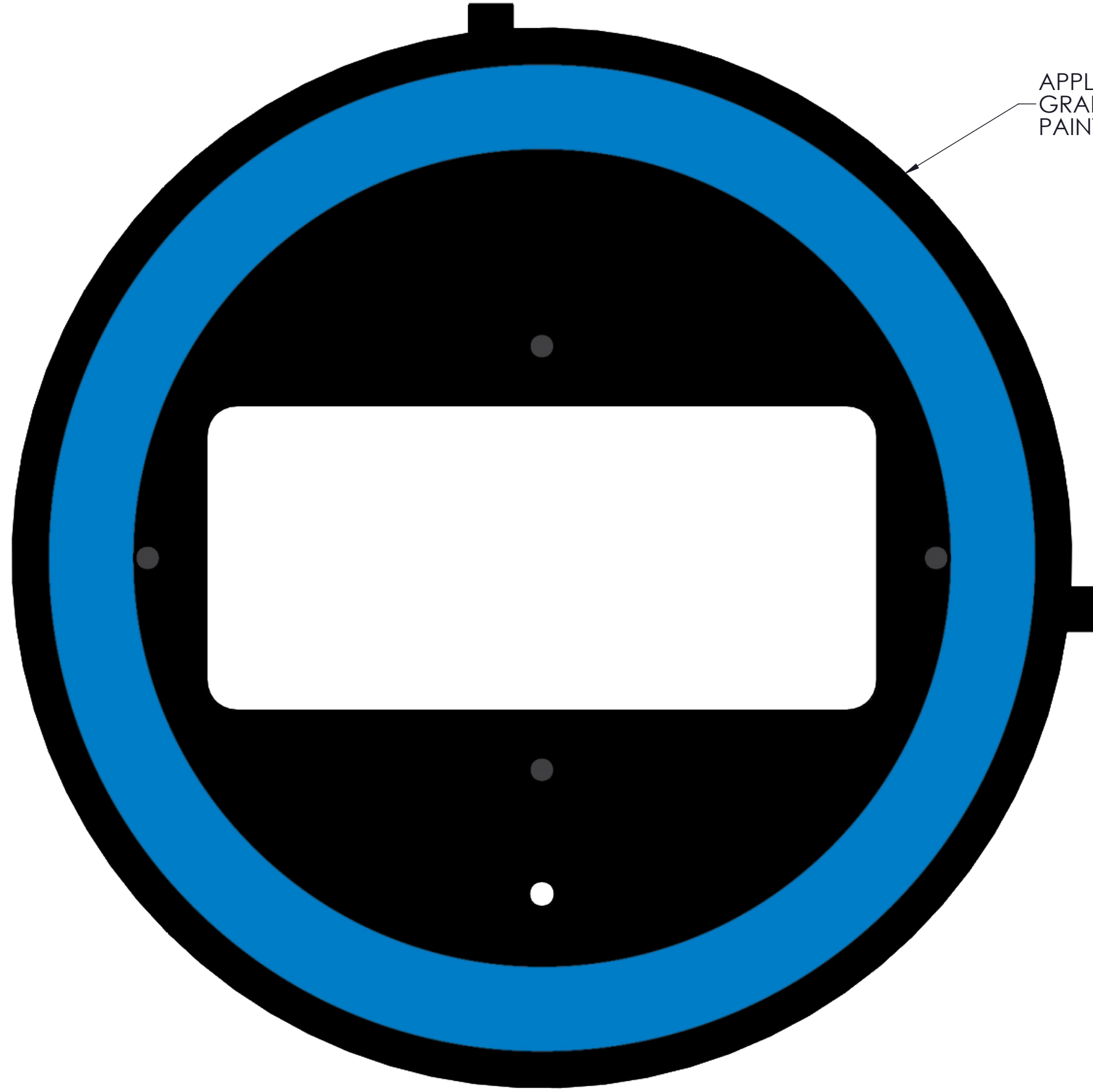

APPLY INK TRANSFER  
GRAPHIC AFTER  
PAINTING

NOTES:

- USE PROVIDED ARTWORK
- 1 COLOR INK TRANSFER; BLUE ONLY
- STANDARD DURATAG WITH BLEND 21 ACTIVATOR TO ADHERE TO BLACK MINI TEX POWDERCOATED METAL

TOLERANCES UNLESS OTHERWISE NOTED XXX ± .015 XX ± .030 HOLE ± .005 ANGLE ± 1°	 AMD Industries Inc. 4620 West 19th Street, Cicero, IL 60804		PART NO PXXXXX
	TITLE ROTATING BRACKET WITH TABS SUBASSEMBLY		
DESIGNED JB	DRAWN JB	MATERIAL N/A	SHEET 2 OF 2
DATE 12/13/17	DATE 12/20/17	FINISH BLACK MINI TEX	

REV	ECN #	DESCRIPTION	DATE	BY
1	XXX	DESIGN INTENT FOR ENGINEERING	12/20/17	JB

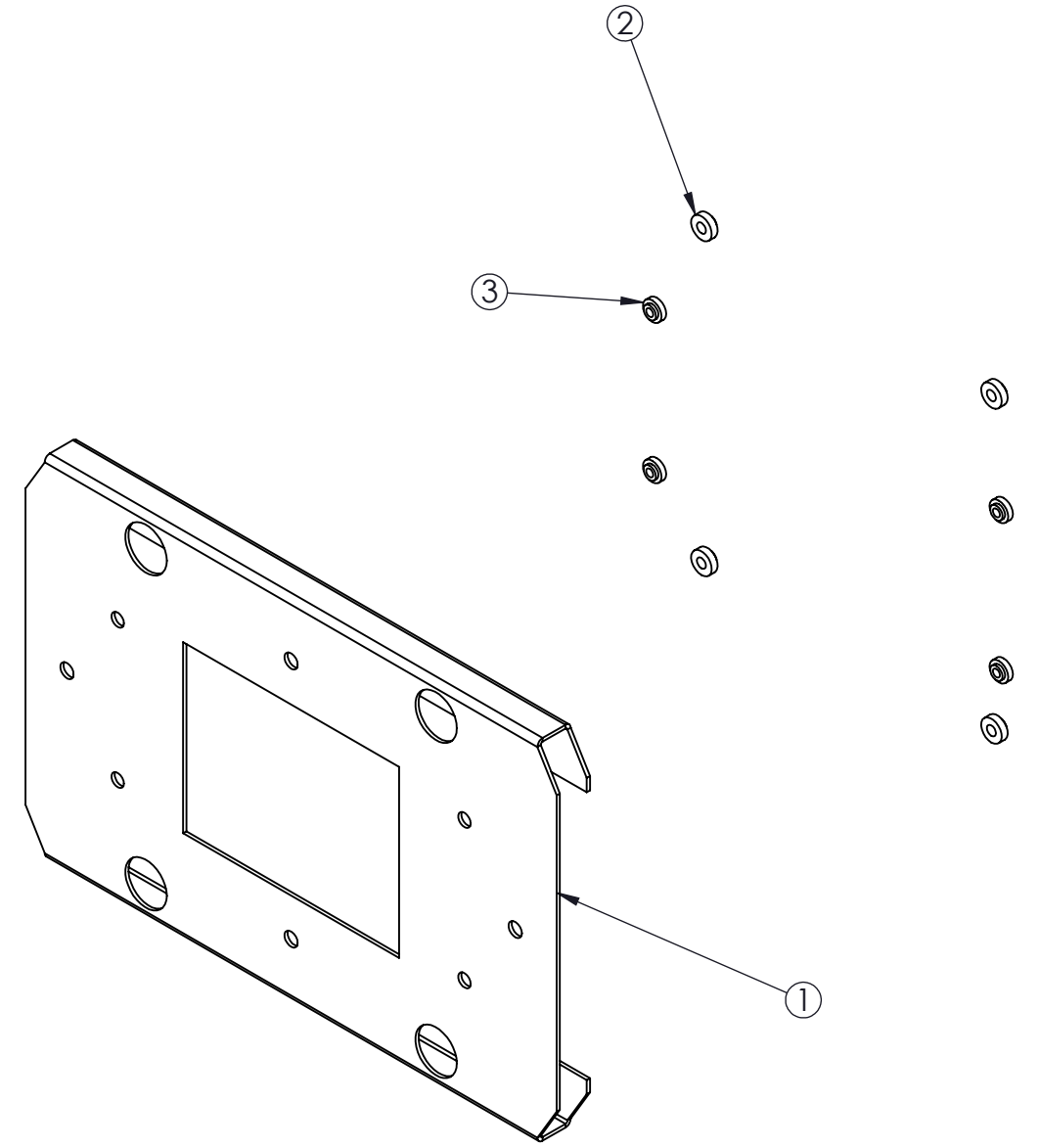
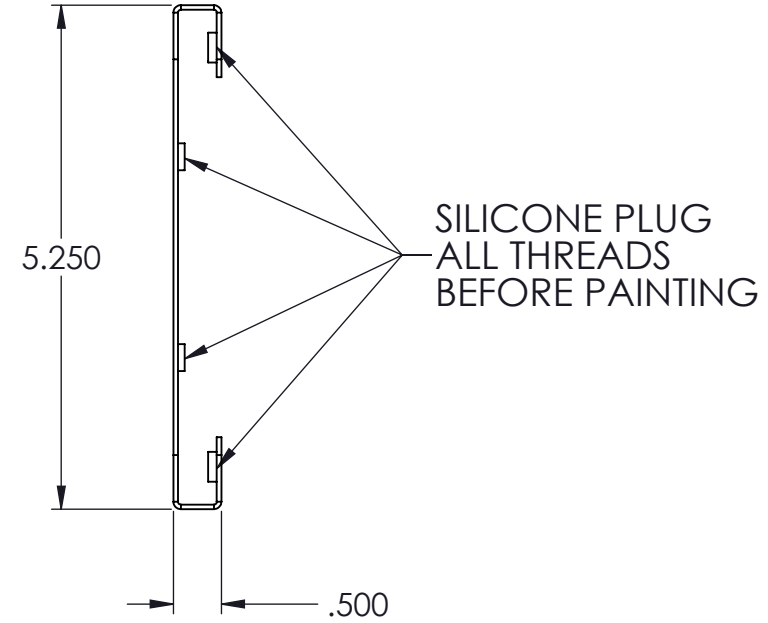
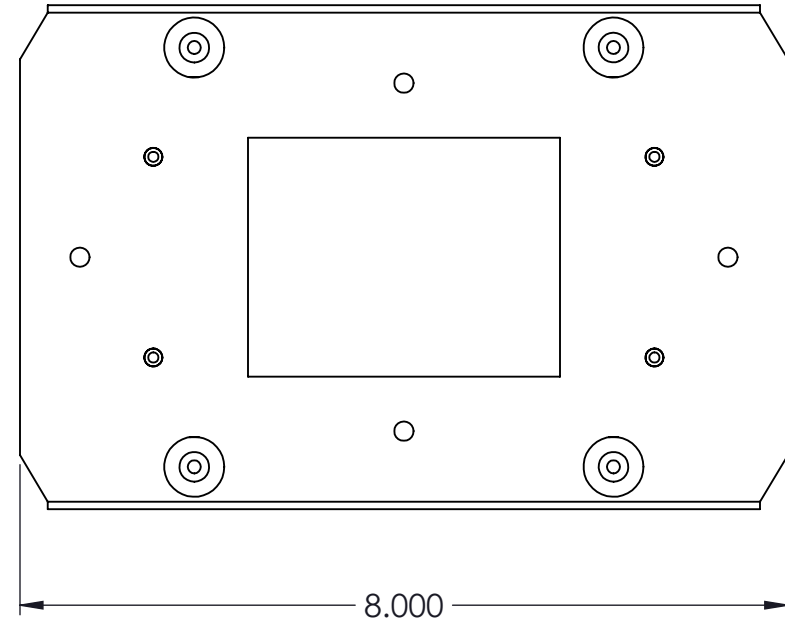
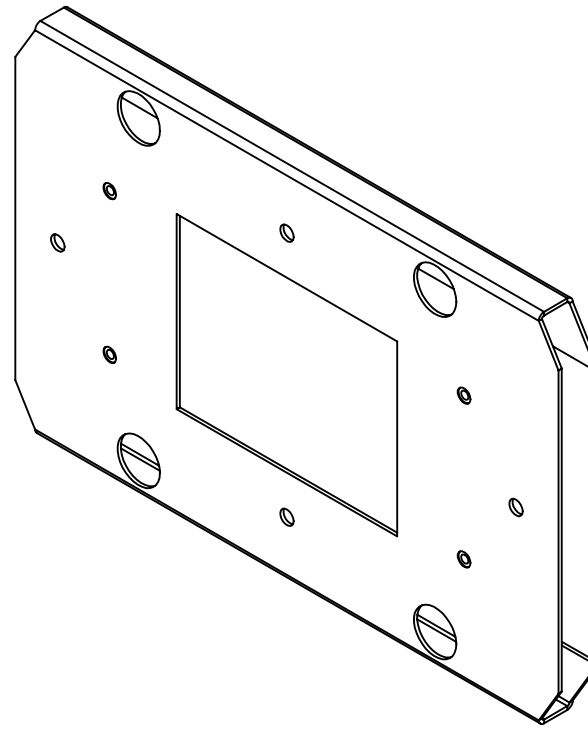
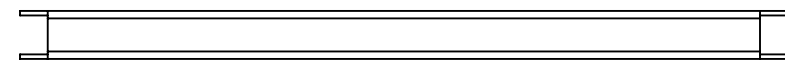

ITEM NO.	PART NUMBER	DESCRIPTION	QTY.
1	Part11	TURNTABLE BRACKET	1
2	P33383	PEM NUT SELF CLINCH 8-32 X .038" PEM #S-832-1ZI	4
3	P33745	PEM NUT SELF CLINCH 6-32 X .038" #S-632-1 ZI	4

TOLERANCES UNLESS OTHERWISE NOTED XXX ± .015 XX ± .030 HOLE ± .005 ANGLE ± 1°		 AMD Industries Inc. 4620 West 19th Street, Cicero, IL 60804	
TITLE TURNTABLE MOUNTING BRACKET SUBASSEMBLY			
DESIGNED JB	DRAWN JB	MATERIAL N/A	PART NO PXXXXX
DATE 12/07/17	DATE 12/20/17	FINISH BLACK MINI TEX	SHEET 1 OF 1

REV	ECN #	DESCRIPTION	DATE	BY
1	XXX	DESIGN INTENT FOR ENGINEERING	12/20/17	JB

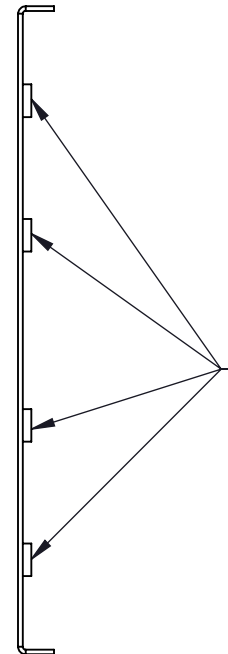
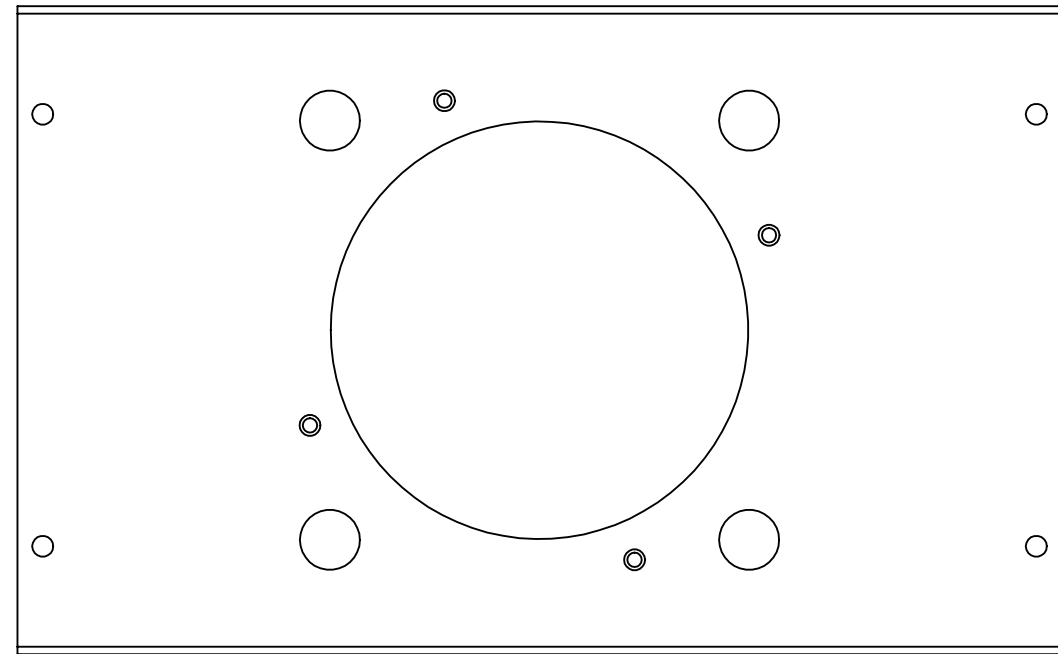
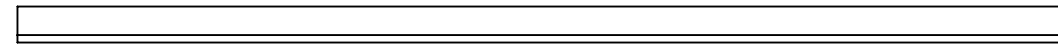

SILICONE PLUG  
ALL THREADS  
BEFORE PAINTING

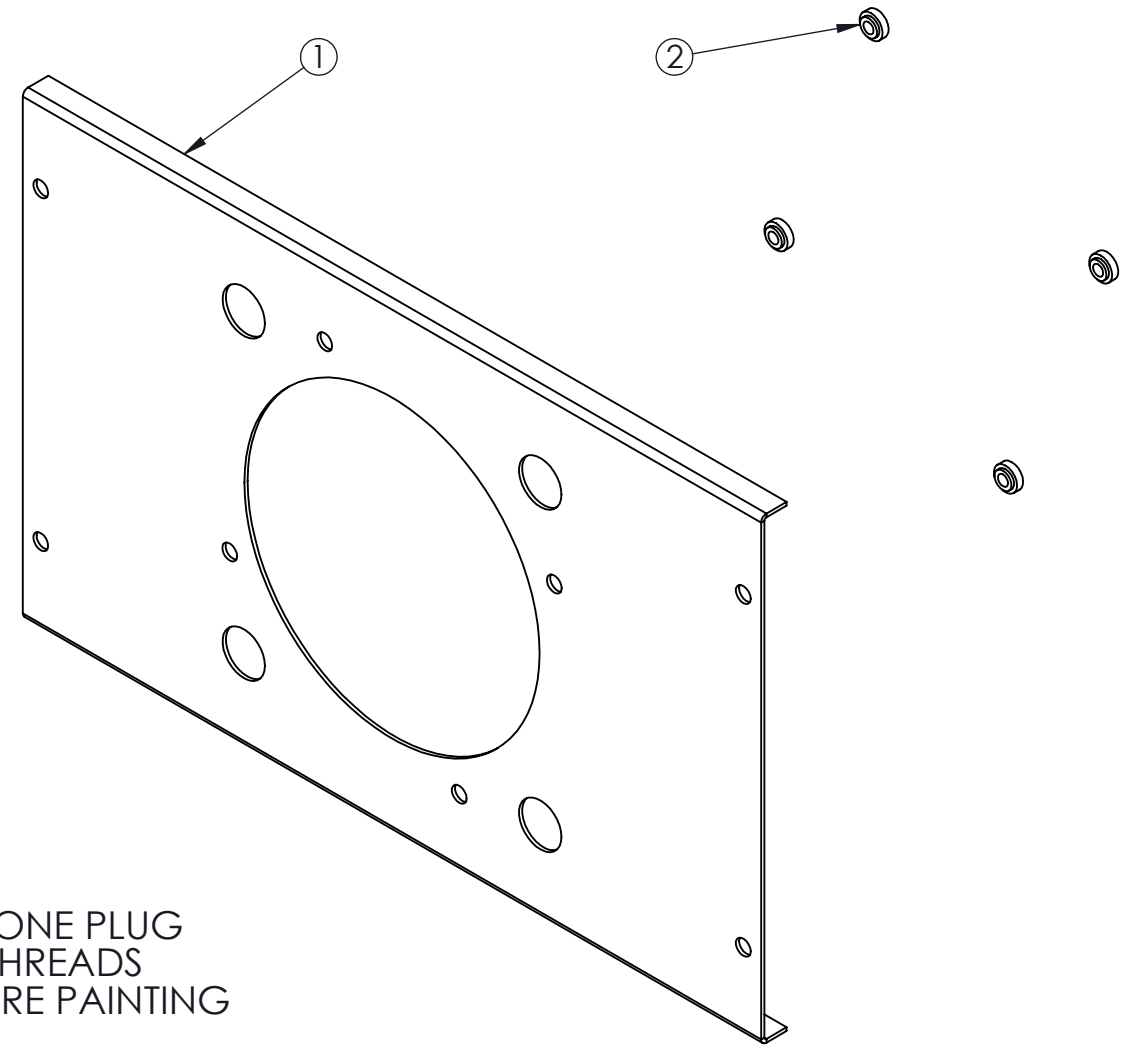

ITEM NO.	PART NUMBER	DESCRIPTION	QTY.
1	Part19	FIXED TURNTABLE BRACKET	1
2	P33318	PEM NUT SELF CLINCH 10-24 X .038" #SS-024-1 ZI	4

TOLERANCES UNLESS OTHERWISE NOTED XXX ± .015 XX ± .030 HOLE ± .005 ANGLE ± 1°		 AMD Industries Inc. 4620 West 19th Street, Cicero, IL 60804	
TITLE FIXED TURNTABLE BRACKET SUBASSEMBLY			
DESIGNED JB	DRAWN JB	MATERIAL N/A	PART NO PXXXXX
DATE 12/11/17	DATE 12/20/17	FINISH BLACK MINI TEX	SHEET 1 OF 1

REV	ECN #	DESCRIPTION	DATE	BY
1	XXX	DESIGN INTENT FOR ENGINEERING	12/20/17	JB

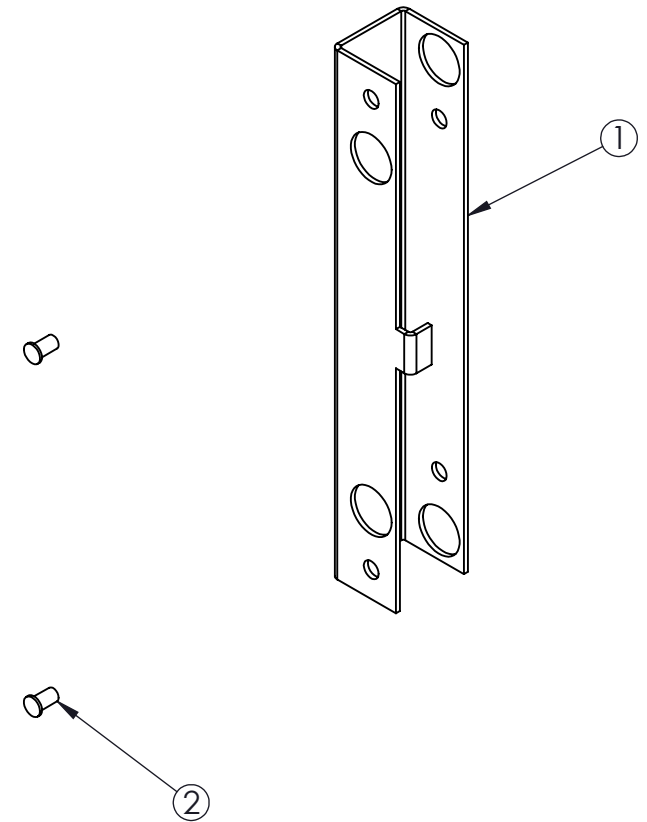
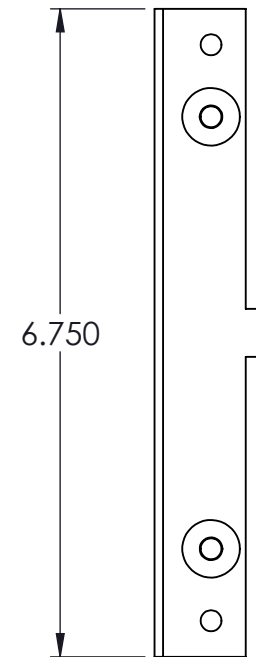
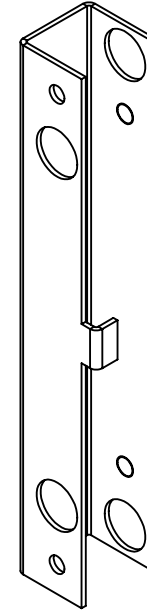
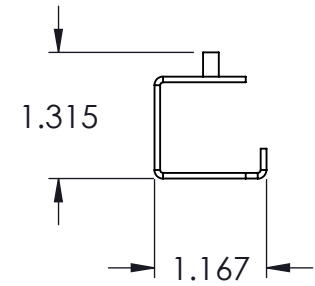

ITEM NO.	PART NUMBER	DESCRIPTION	QTY.
1	Part23	BRACKET	1
2	P36073	PEM STUD SELF CLINCH FLUSH 8-32 X 5/16" #FH-832-5 ZI	2

TOLERANCES UNLESS OTHERWISE NOTED XXX ± .015 XX ± .030 HOLE ± .005 ANGLE ± 1°		 AMD Industries Inc. 4620 West 19th Street, Cicero, IL 60804	
DESIGNED JB		TITLE BRACKET ASSEMBLY	
DATE 12/10/17		PART NO PXXXXX	
DRAWN JB		MATERIAL N/A	
DATE 12/20/17		FINISH BLACK MINI TEX	
		SHEET 1 OF 1	

REV	ECN #	DESCRIPTION	DATE	BY
1	XXX	DESIGN INTENT FOR ENGINEERING	12/20/17	JB

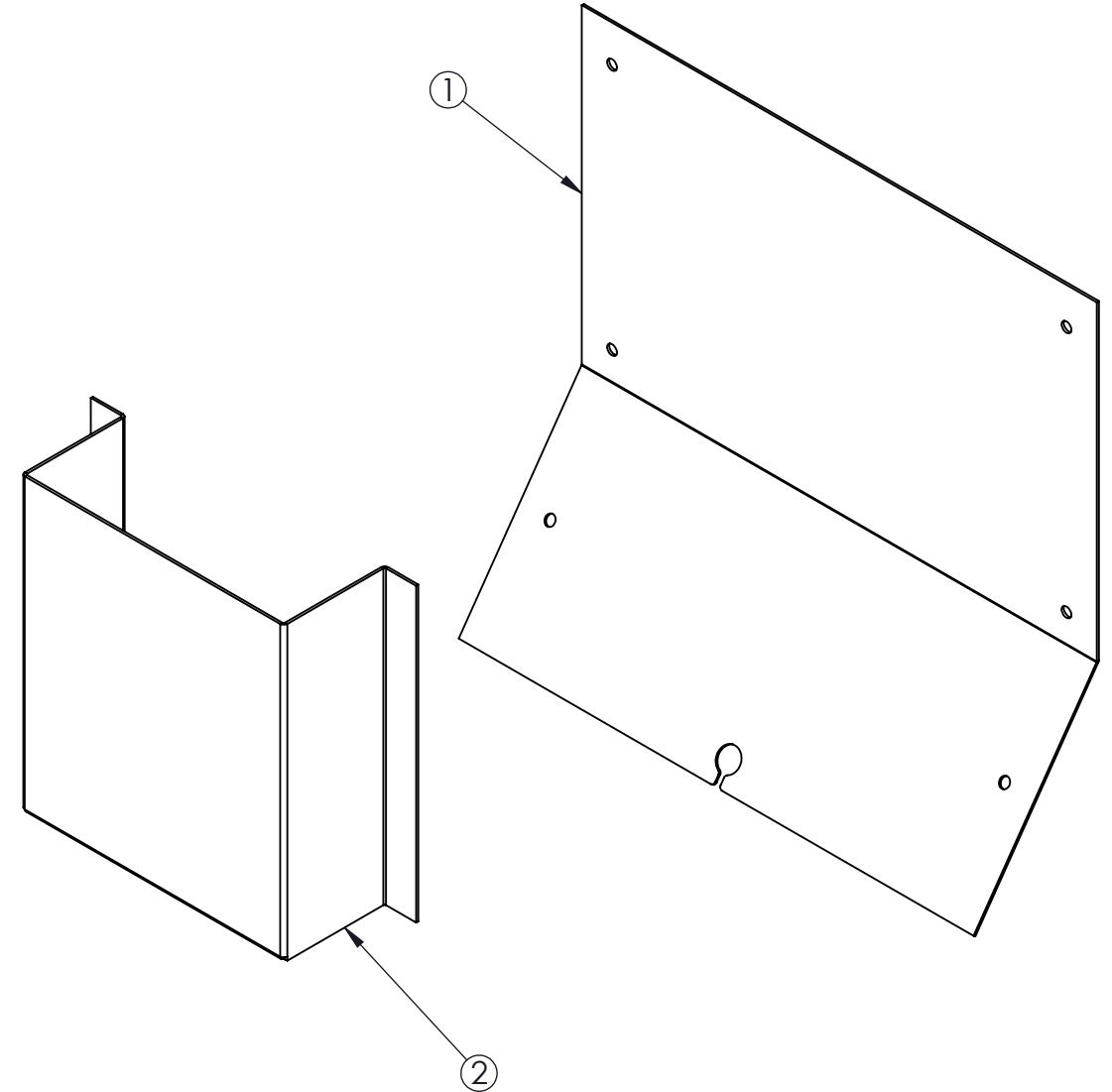
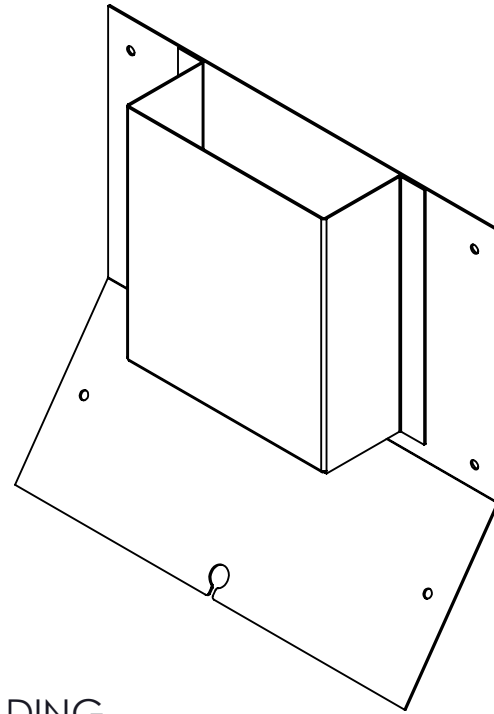
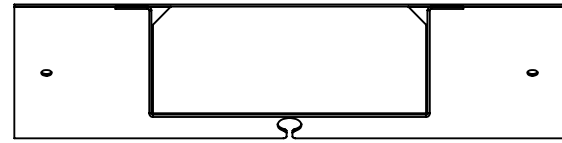

FLUSH BEFORE WELDING

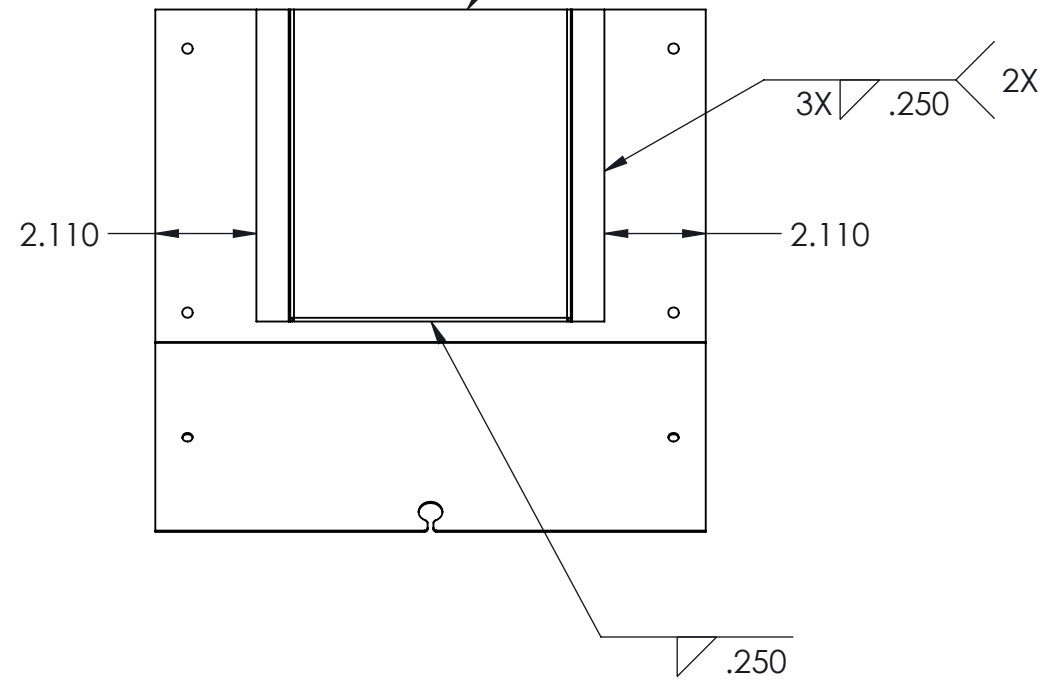

ITEM NO.	PART NUMBER	DESCRIPTION	QTY.
1	Part22	BACK COVER	1
2	Part3	BROCHURE POCKET	1

TOLERANCES UNLESS OTHERWISE NOTED XXX ± .015 XX ± .030 HOLE ± .005 ANGLE ± 1°		 AMD Industries Inc. 4620 West 19th Street, Cicero, IL 60804	
DESIGNED JB		TITLE BACK COVER WELDMENT	
DATE 12/09/17	DRAWN JB	MATERIAL N/A	PART NO PXXXXX
	DATE 12/20/17	FINISH BLACK MINI TEX	SHEET 1 OF 1

REV	ECN #	DESCRIPTION	DATE	BY
1	XXX	DESIGN INTENT FOR ENGINEERING	12/20/17	JB

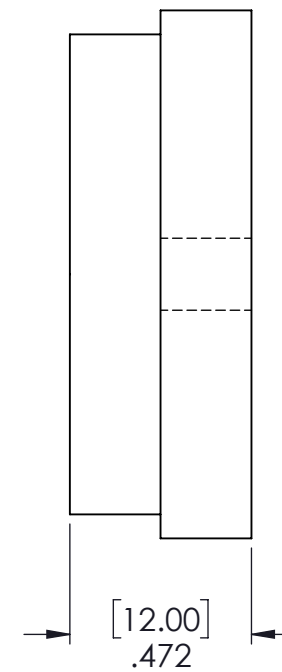
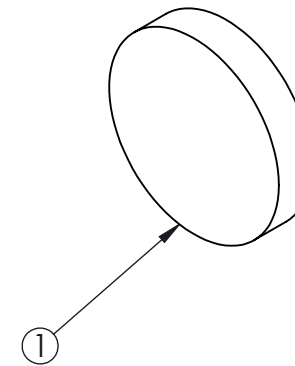
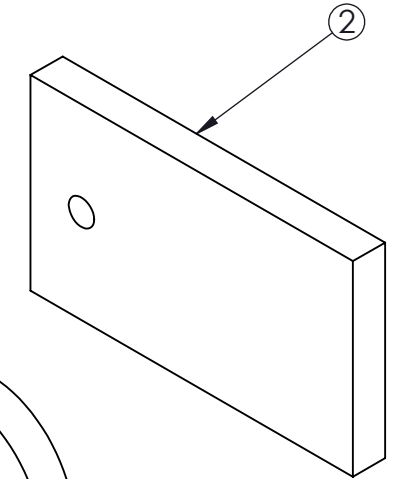
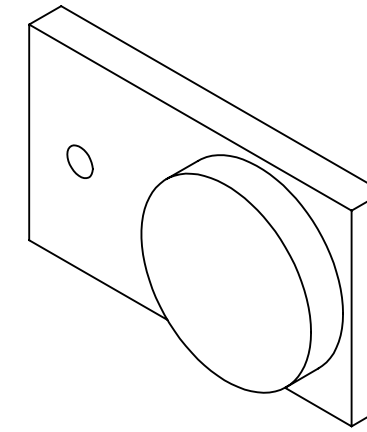
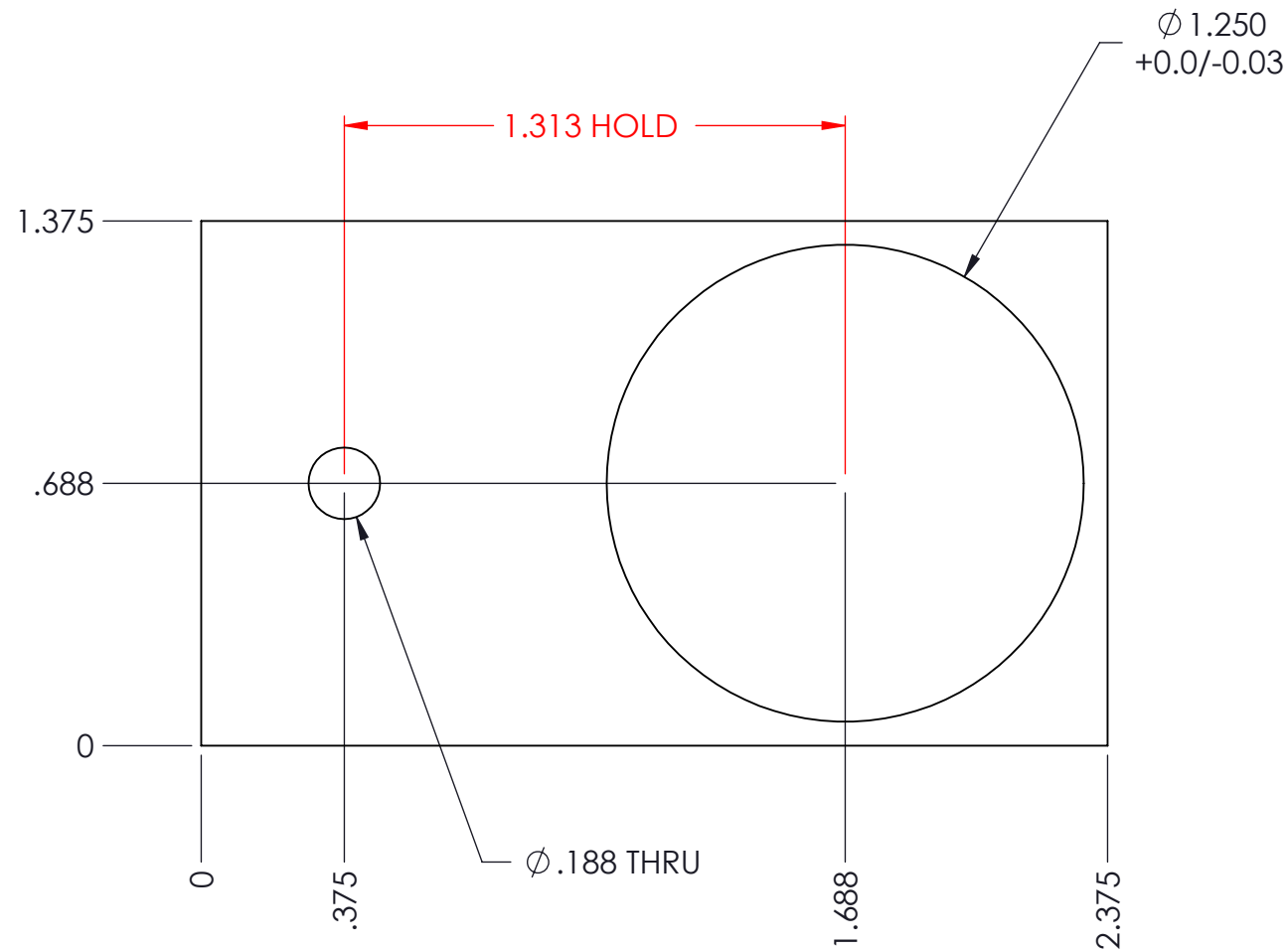
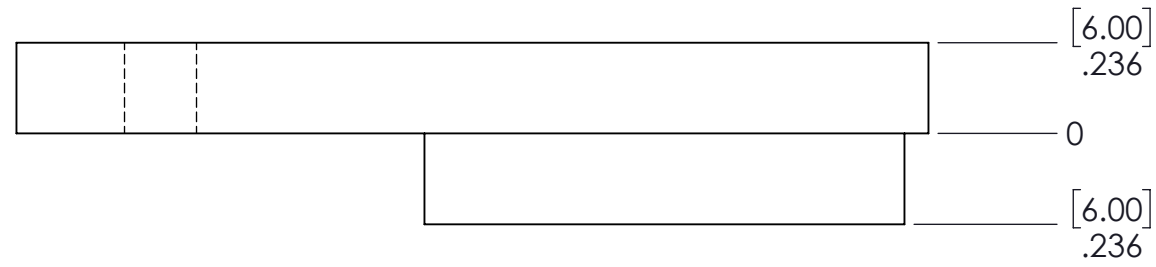

NOTES:  
LASER CUT, SOLVENT BOND  
SEE NEXT PAGE FOR INK TRANSFER DIRECTION

ITEM NO.	PART NUMBER	DESCRIPTION	QTY.
1	Part15	ACRYLIC LOGO CIRCLE	1
2	Part16	ACRYLIC LOGO BACKER	1

TOLERANCES UNLESS OTHERWISE NOTED XXX ± .015 XX ± .030 HOLE ± .005 ANGLE ± 1°		 AMD Industries Inc. 4620 West 19th Street, Cicero, IL 60804	
DESIGNED JB		TITLE BACKLIT DIMENSIONAL GRAPHIC	
DATE 12/13/17		PART NO PXXXXX	
DRAWN JB		FINISH XXXXXXXXXX	
DATE 12/20/17		SHEET 1 OF 2	



REV	ECN #	DESCRIPTION	DATE	BY
1	XXX	DESIGN INTENT FOR ENGINEERING	12/20/17	JB

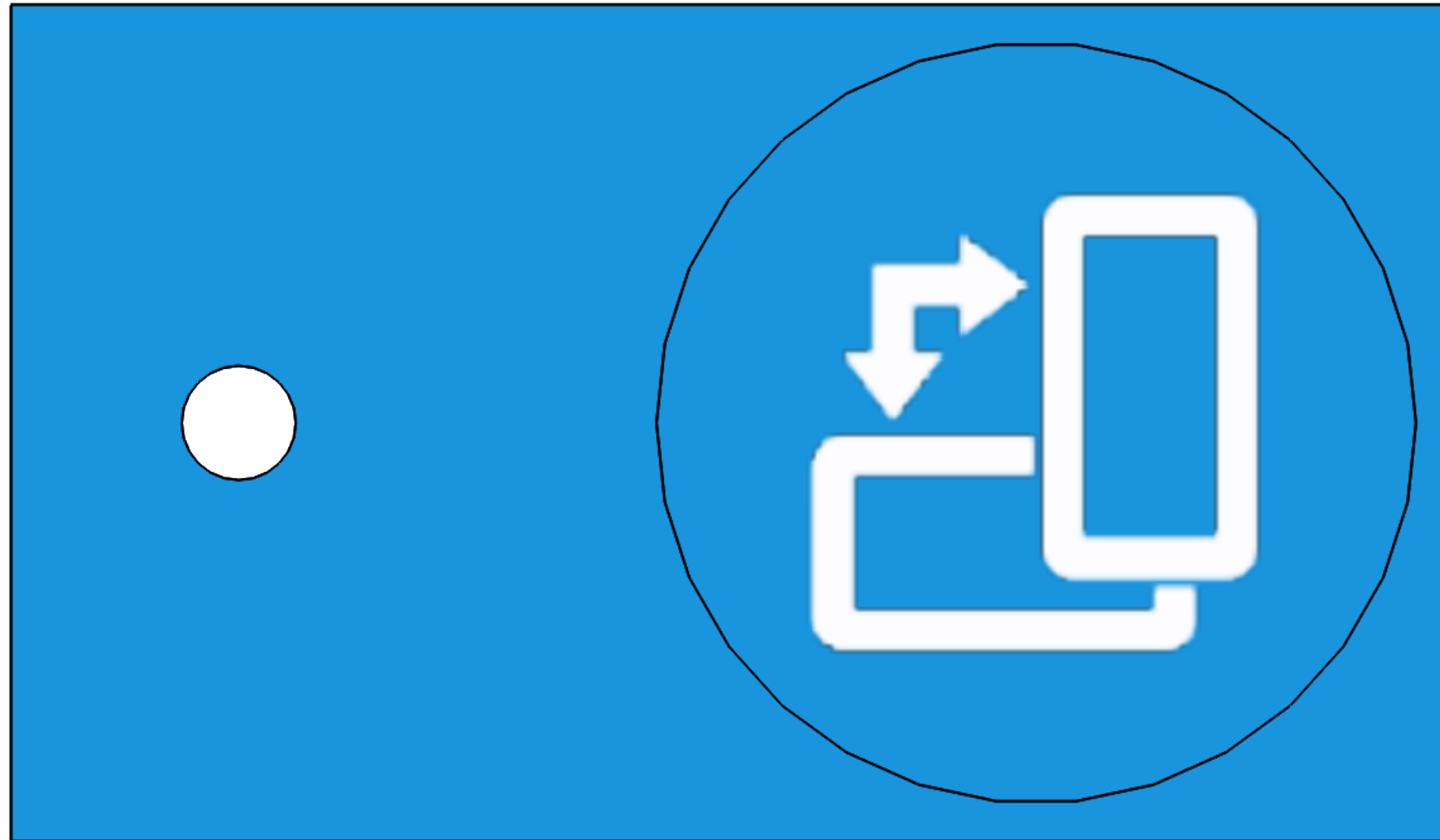

- NOTES:
- APPLY INK TRANSFER AFTER SOLVENT BONDING
  - USE PROVIDED ARTWORK
  - 1 COLOR INK TRANSFER; WHITE ONLY
  - STANDARD DURATAG WITH BLEND 21 ACTIVATOR TO ADHERE TO ACRYLIC

TOLERANCES UNLESS OTHERWISE NOTED XXX ± .015 XX ± .030 HOLE ± .005 ANGLE ± 1°	 AMD Industries Inc. 4620 West 19th Street, Cicero, IL 60804		
	TITLE BACKLIT DIMENSIONAL GRAPHIC		
DESIGNED JB	DRAWN JB	MATERIAL N/A	PART NO PXXXXX
DATE 12/13/17	DATE 12/20/17	FINISH XXXXXXXXXX	SHEET 2 OF 2

REV	ECN #	DESCRIPTION	DATE	BY
1	XXX	DESIGN INTENT FOR ENGINEERING	12/20/17	JB

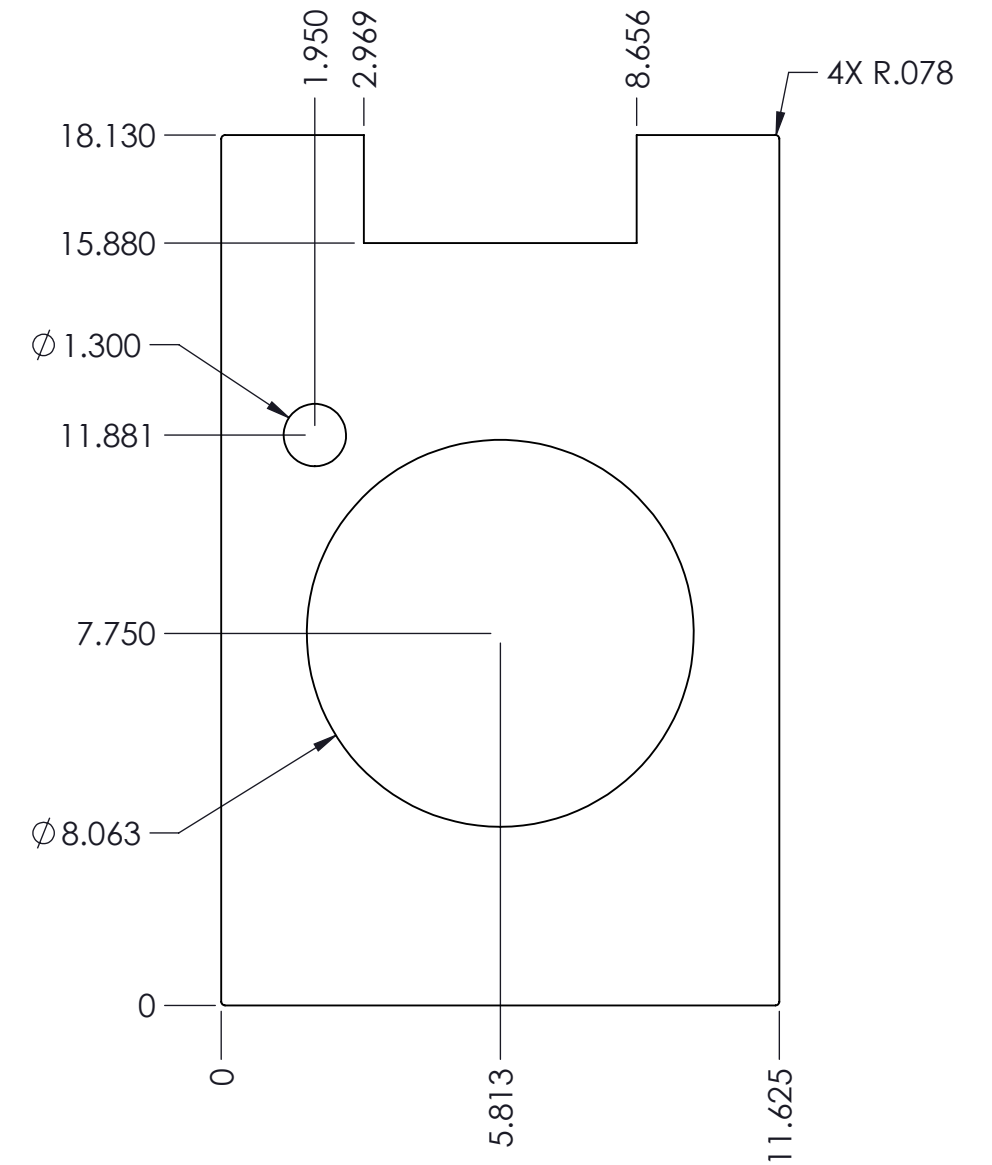
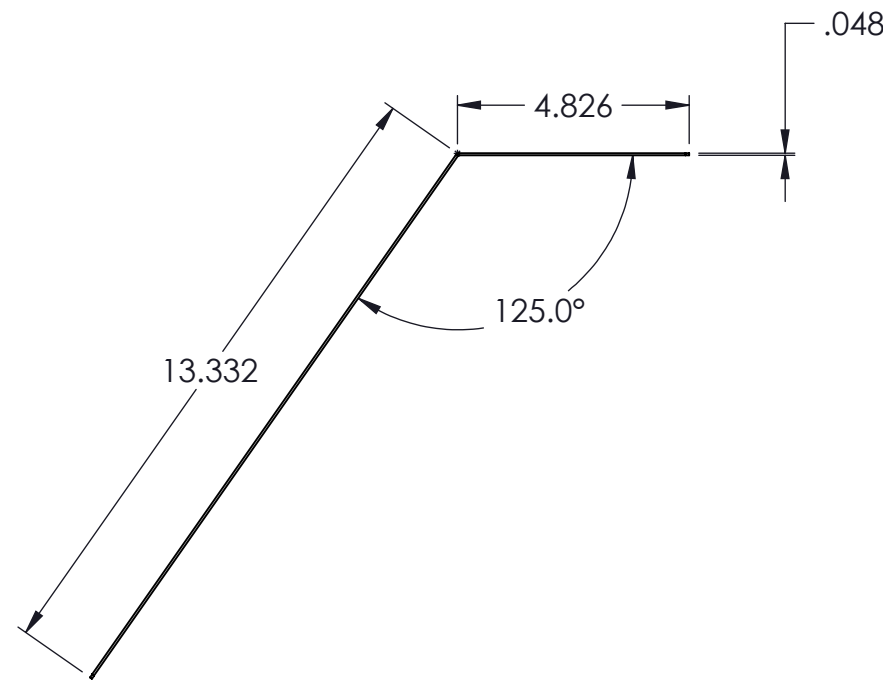
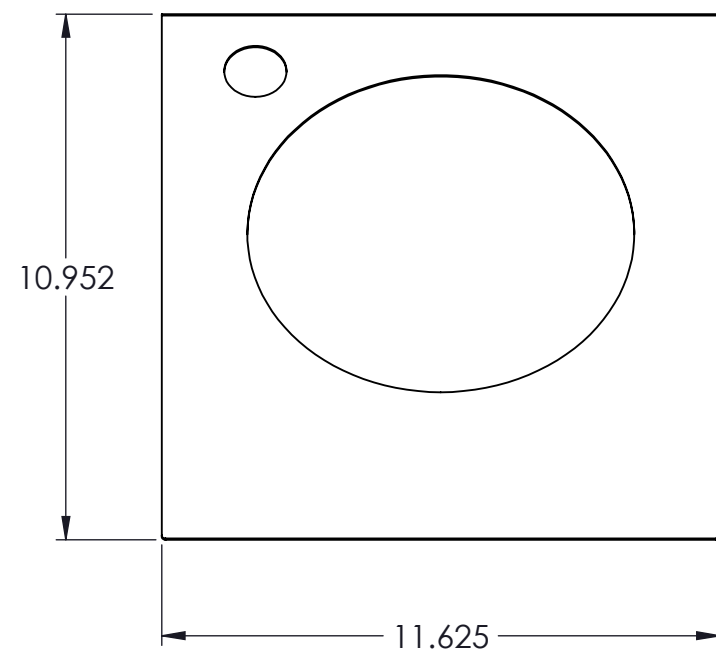
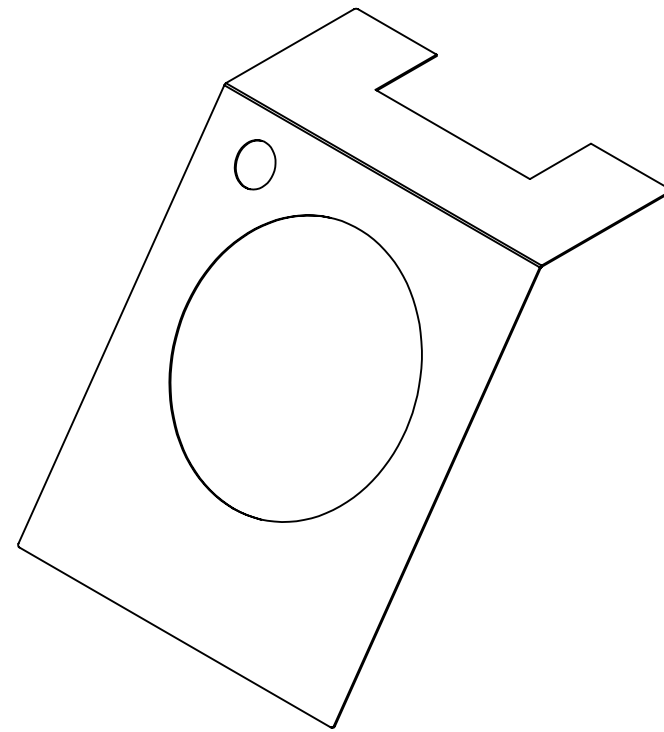
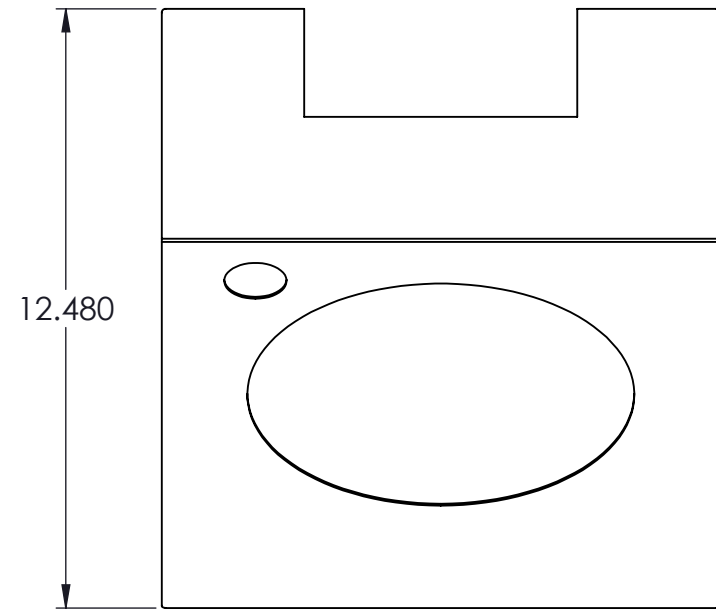

TOLERANCES UNLESS OTHERWISE NOTED XXX ± .015 XX ± .030 HOLE ± .005 ANGLE ± 1°		 AMD Industries Inc. 4620 West 19th Street, Cicero, IL 60804	
DESIGNED JB		TITLE FRONT	
DATE 12/11/17	DRAWN JB	MATERIAL 18 GA (.048) CRS	PART NO PXXXXX
	DATE 12/20/17	FINISH XXXXXXXXXX	SHEET 1 OF 1

REV	ECN #	DESCRIPTION	DATE	BY
1	XXX	DESIGN INTENT FOR ENGINEERING	12/20/17	JB

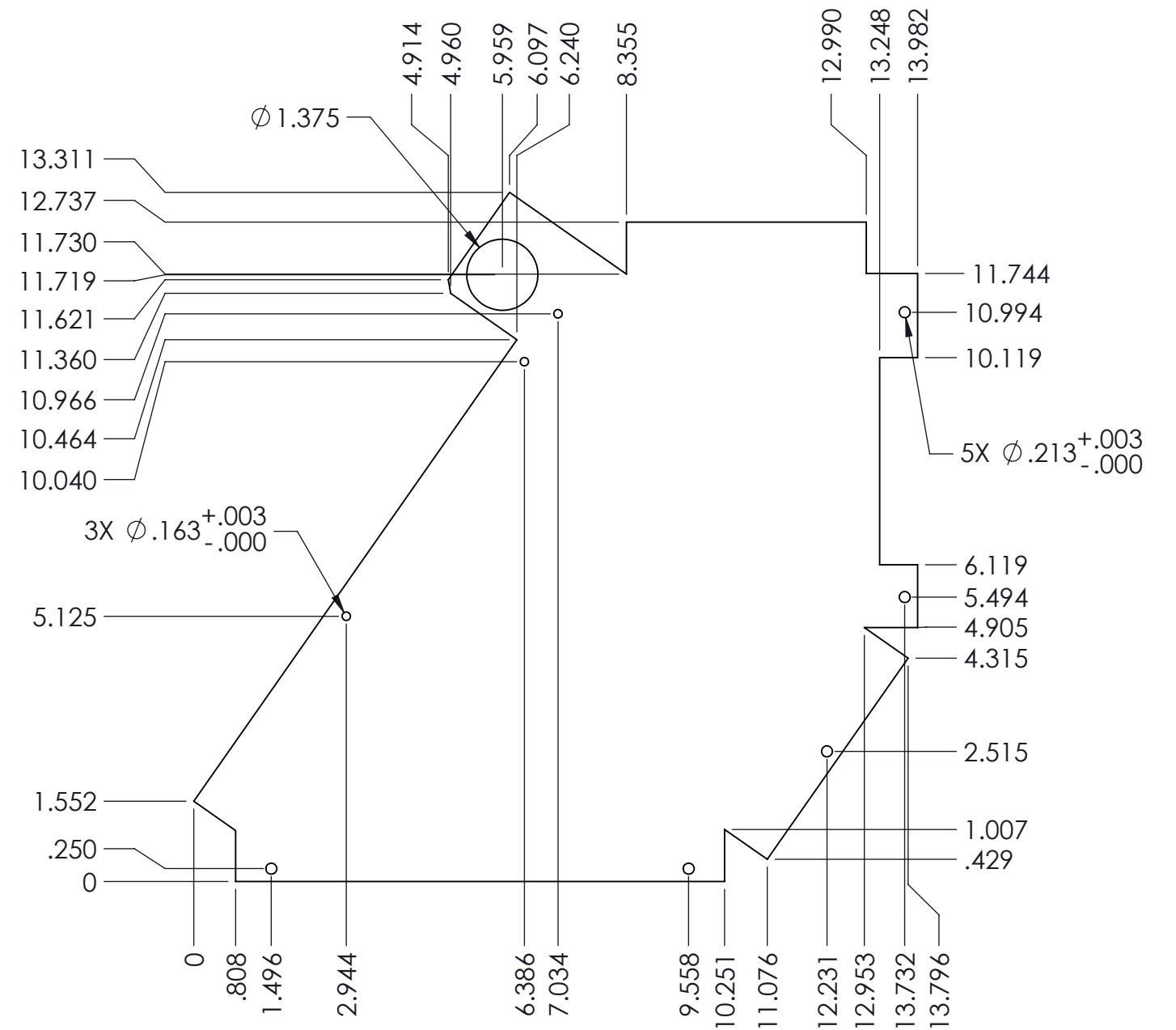
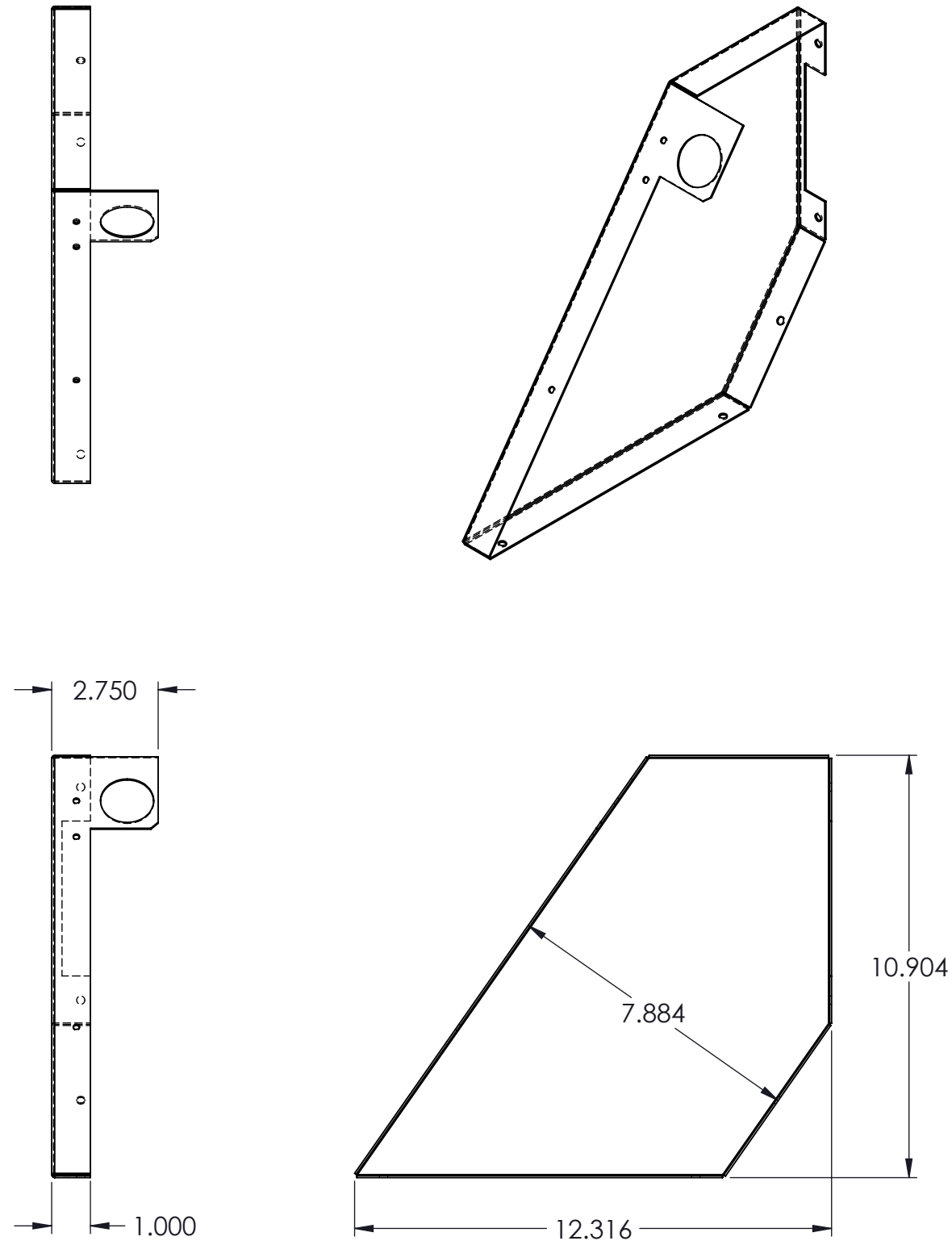

TOLERANCES UNLESS OTHERWISE NOTED XXX ± .015 XX ± .030 HOLE ± .005 ANGLE ± 1°			AMD Industries Inc. 4620 West 19th Street, Cicero, IL 60804
	TITLE SIDE LEFT		
DESIGNED JB	DRAWN JB	MATERIAL 18 GA (.048) CRS	PART NO PXXXXX
DATE 12/07/17	DATE 12/20/17	FINISH XXXXXXXXXX	SHEET 1 OF 1

REV	ECN #	DESCRIPTION	DATE	BY
1	XXX	DESIGN INTENT FOR ENGINEERING	12/20/17	JB

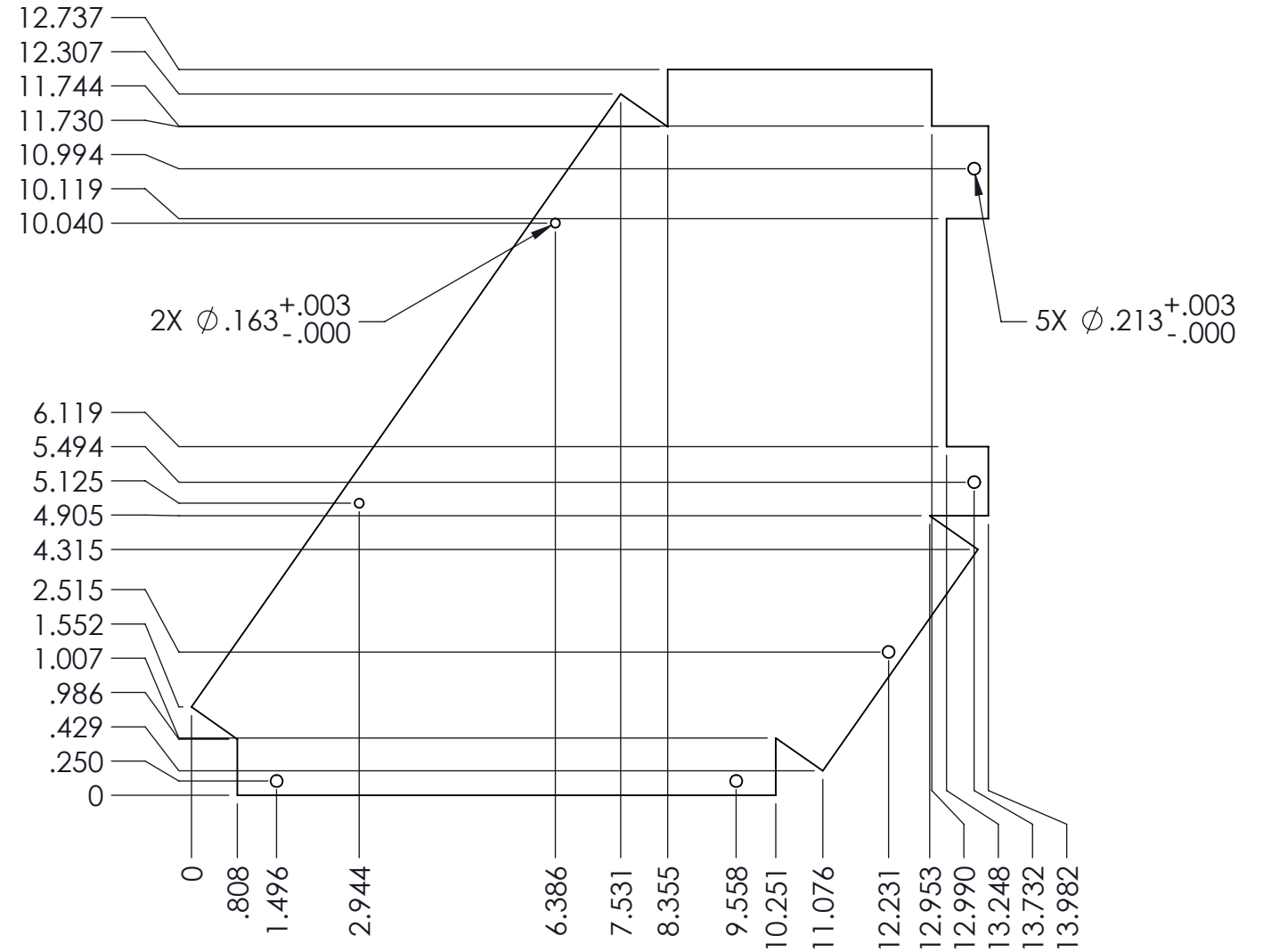
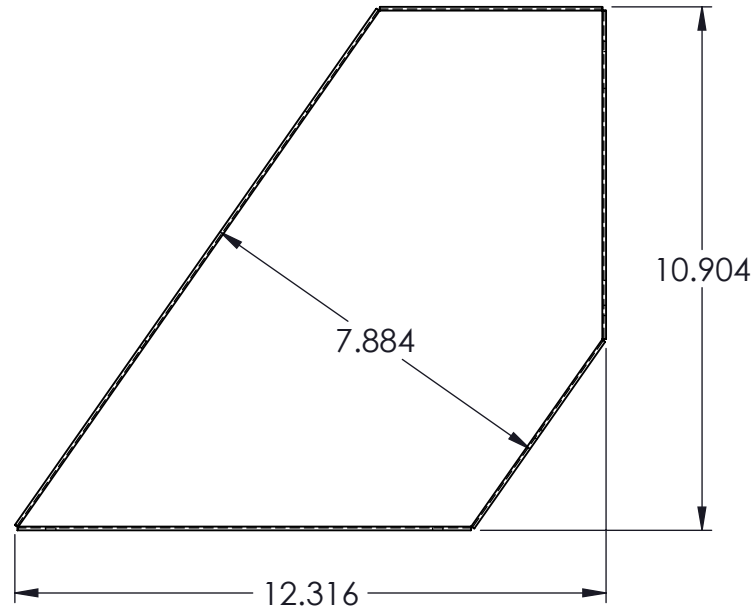
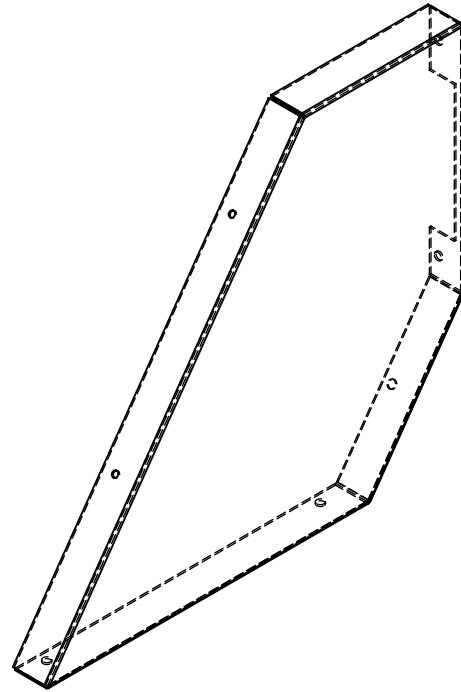
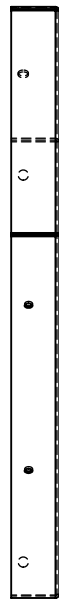

1.000

TOLERANCES UNLESS OTHERWISE NOTED XXX ± .015 XX ± .030 HOLE ± .005 ANGLE ± 1°			AMD Industries Inc. 4620 West 19th Street, Cicero, IL 60804
	TITLE SIDE RIGHT		
DESIGNED JB	DRAWN JB	MATERIAL 18 GA (.048) CRS	PART NO PXXXXX
DATE 12/07/17	DATE 12/20/17	FINISH XXXXXXXXXX	SHEET 1 OF 1

REV	ECN #	DESCRIPTION	DATE	BY
1	XXX	DESIGN INTENT FOR ENGINEERING	12/20/17	JB

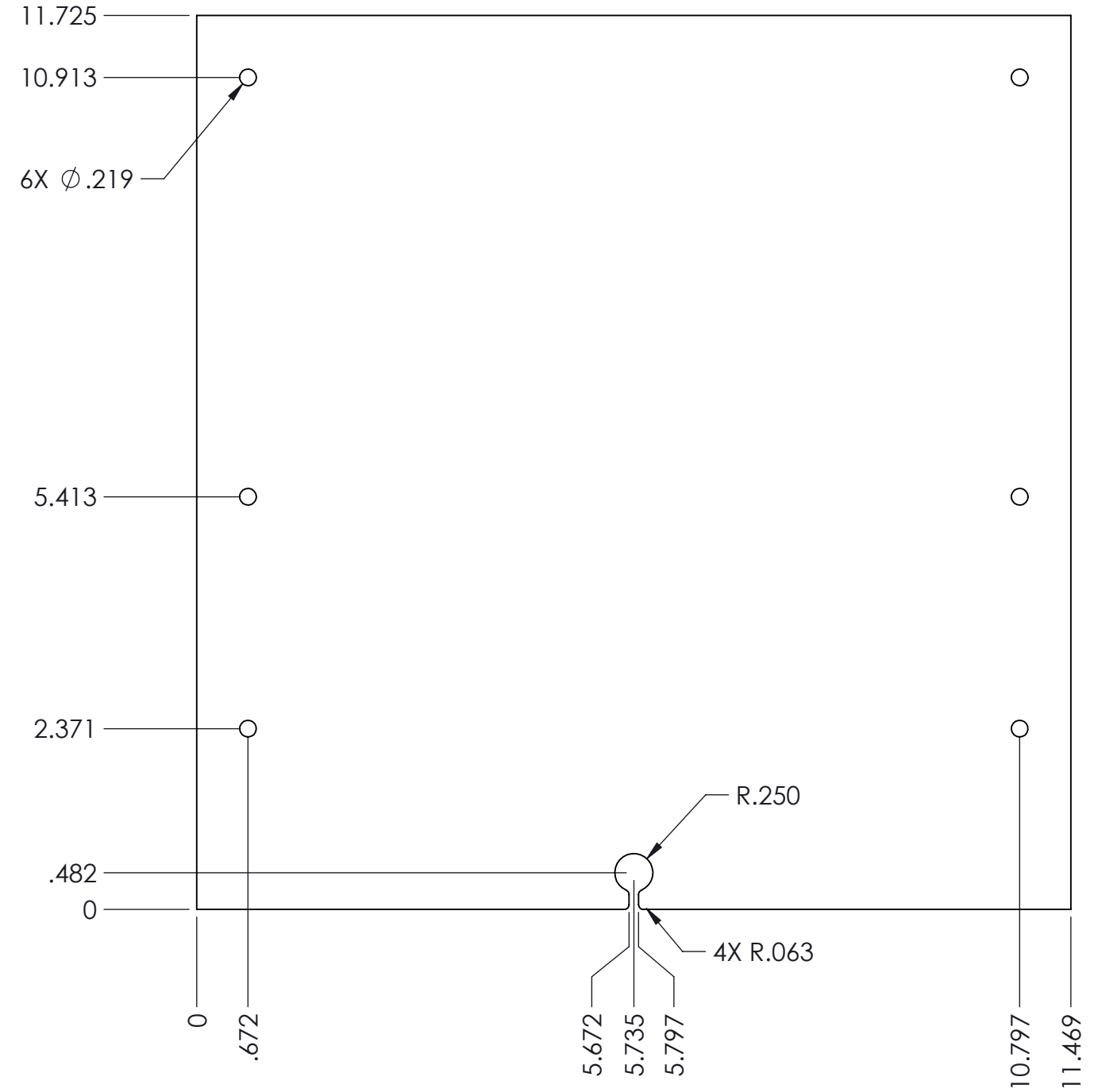
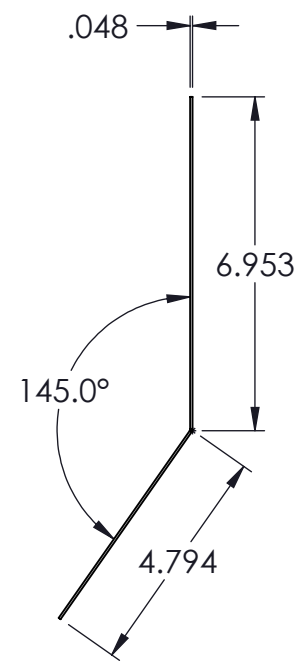
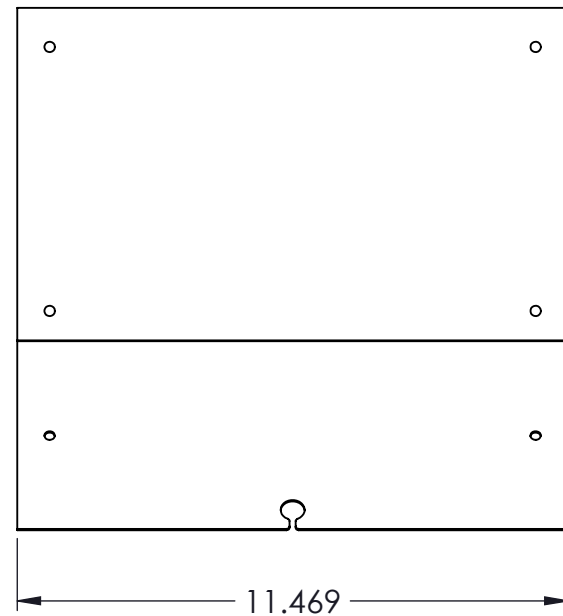
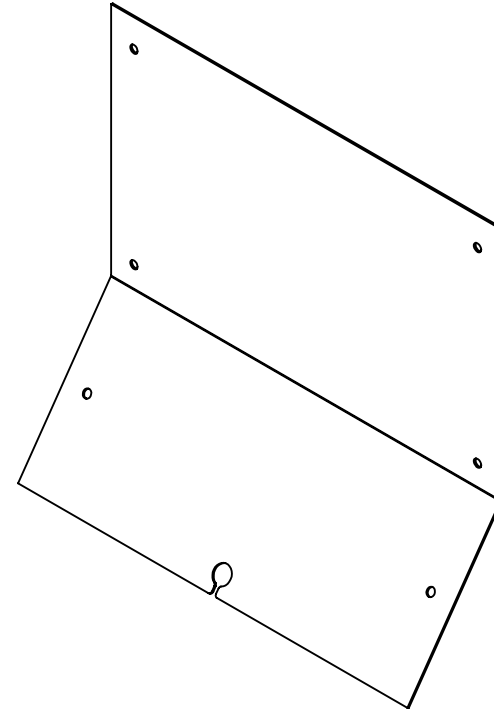
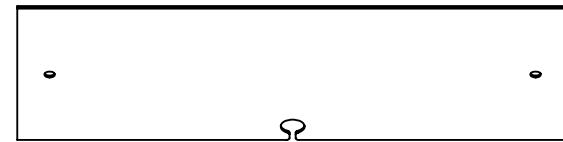

TOLERANCES UNLESS OTHERWISE NOTED XXX ± .015 XX ± .030 HOLE ± .005 ANGLE ± 1°		 AMD Industries Inc. 4620 West 19th Street, Cicero, IL 60804	
DESIGNED JB		TITLE BACK COVER	
DATE 12/10/17	DRAWN JB	MATERIAL 18 GA (.048) CRS	PART NO PXXXXX
	DATE 12/20/17	FINISH BLACK MINI TEX	SHEET 1 OF 1

REV	ECN #	DESCRIPTION	DATE	BY
1	XXX	DESIGN INTENT FOR ENGINEERING	12/20/17	JB

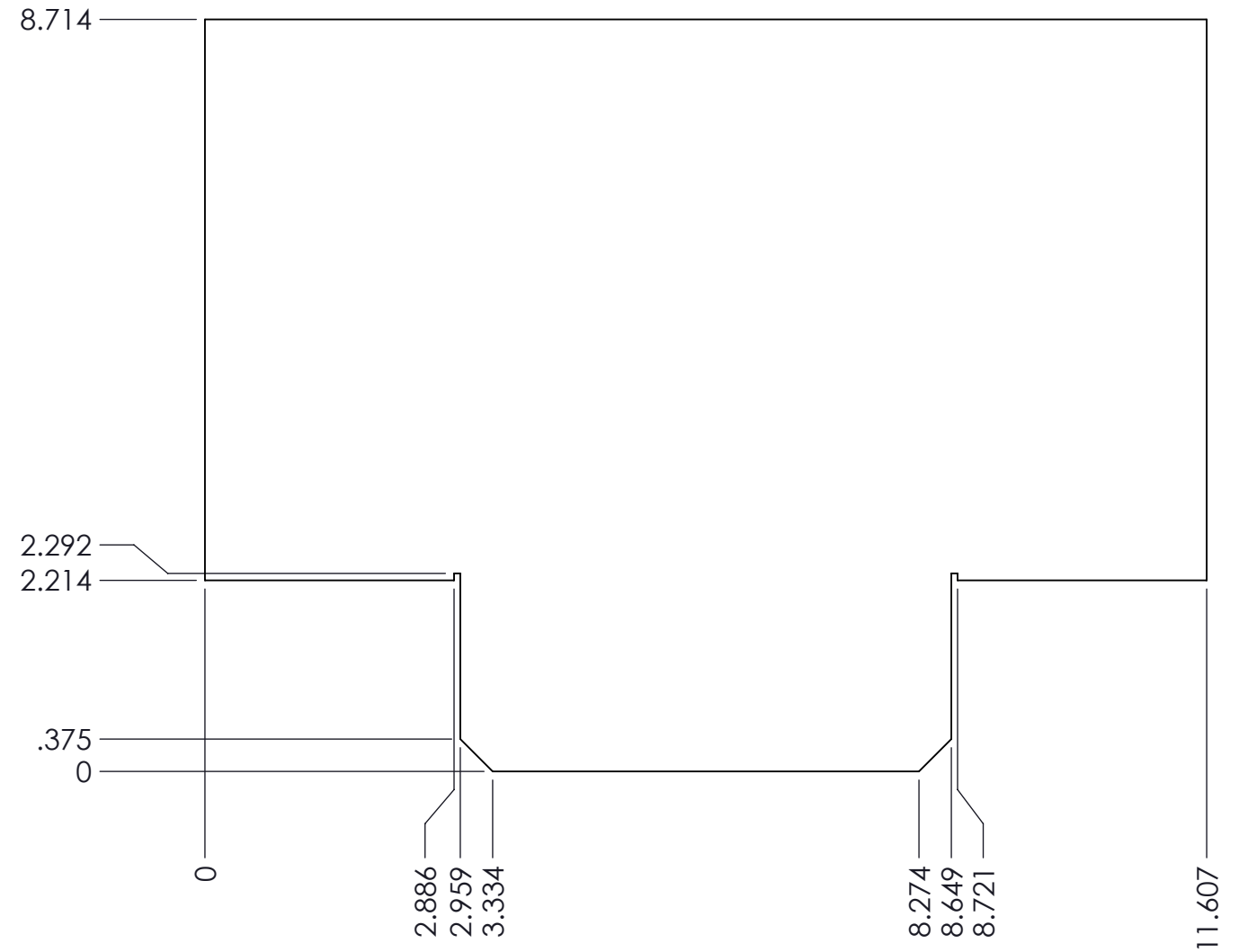
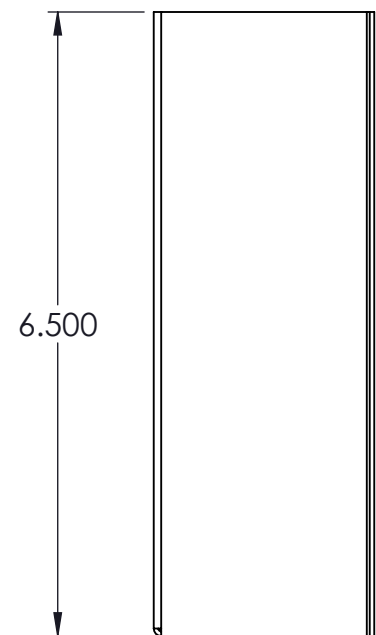
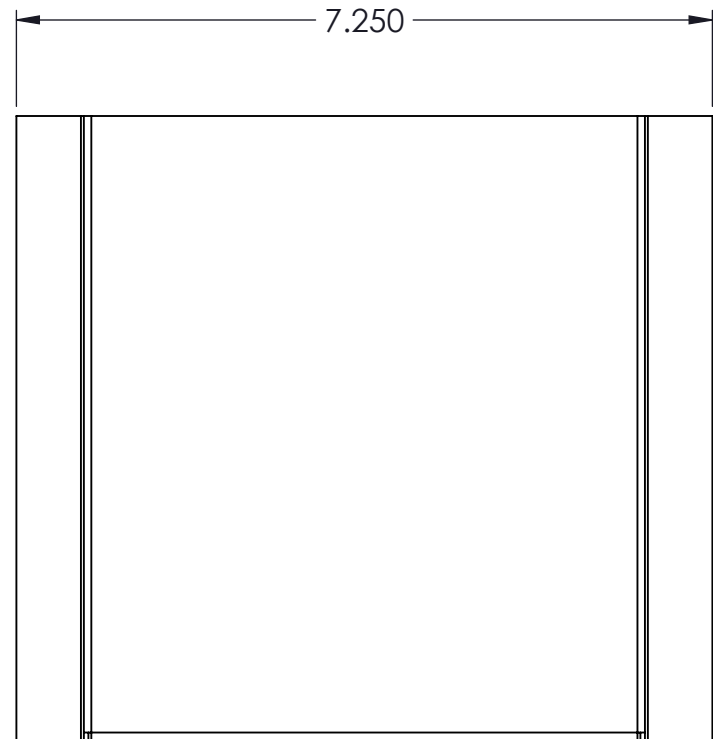
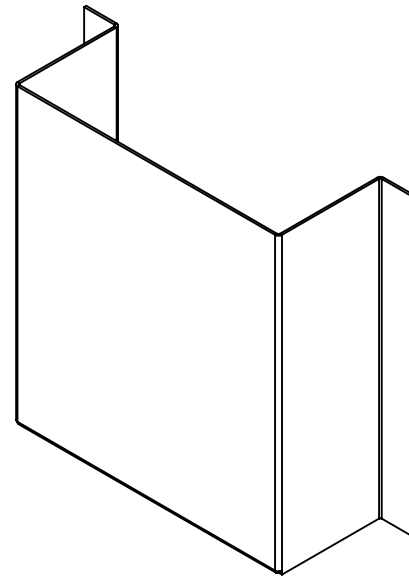
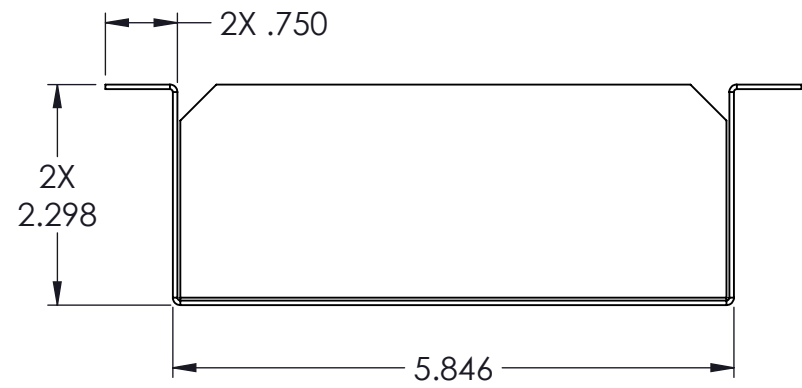

TOLERANCES UNLESS OTHERWISE NOTED XXX ± .015 XX ± .030 HOLE ± .005 ANGLE ± 1°		 AMD Industries Inc. 4620 West 19th Street, Cicero, IL 60804	
DESIGNED JB		DRAWN JB	
DATE 12/11/17		DATE 12/20/17	
MATERIAL 18 GA (.048) CRS		FINISH XXXXXXXXXX	
TITLE BROCHURE POCKET		PART NO PXXXXX	
		SHEET 1 OF 1	

REV	ECN #	DESCRIPTION	DATE	BY
1	XXX	DESIGN INTENT FOR ENGINEERING	12/20/17	JB

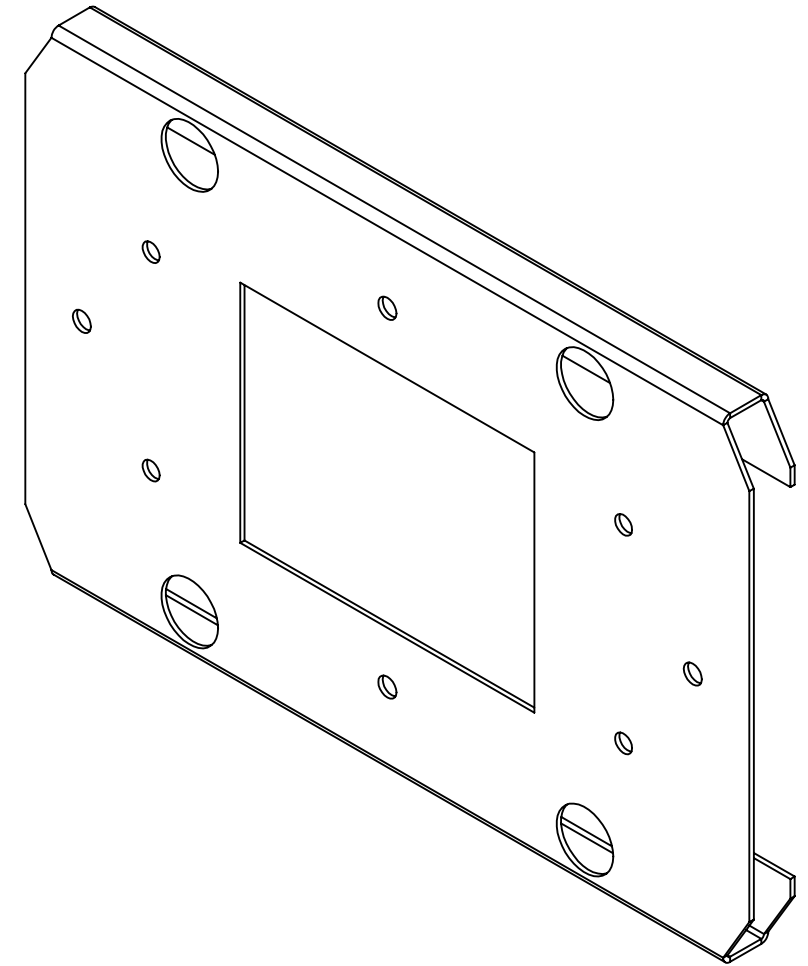
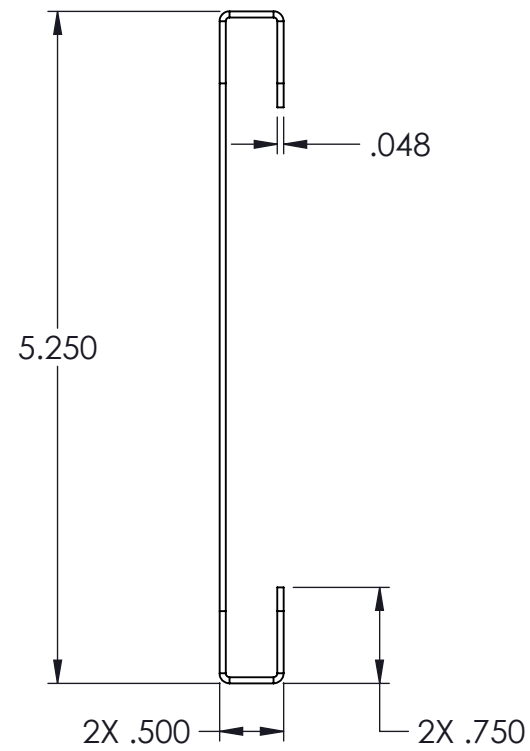
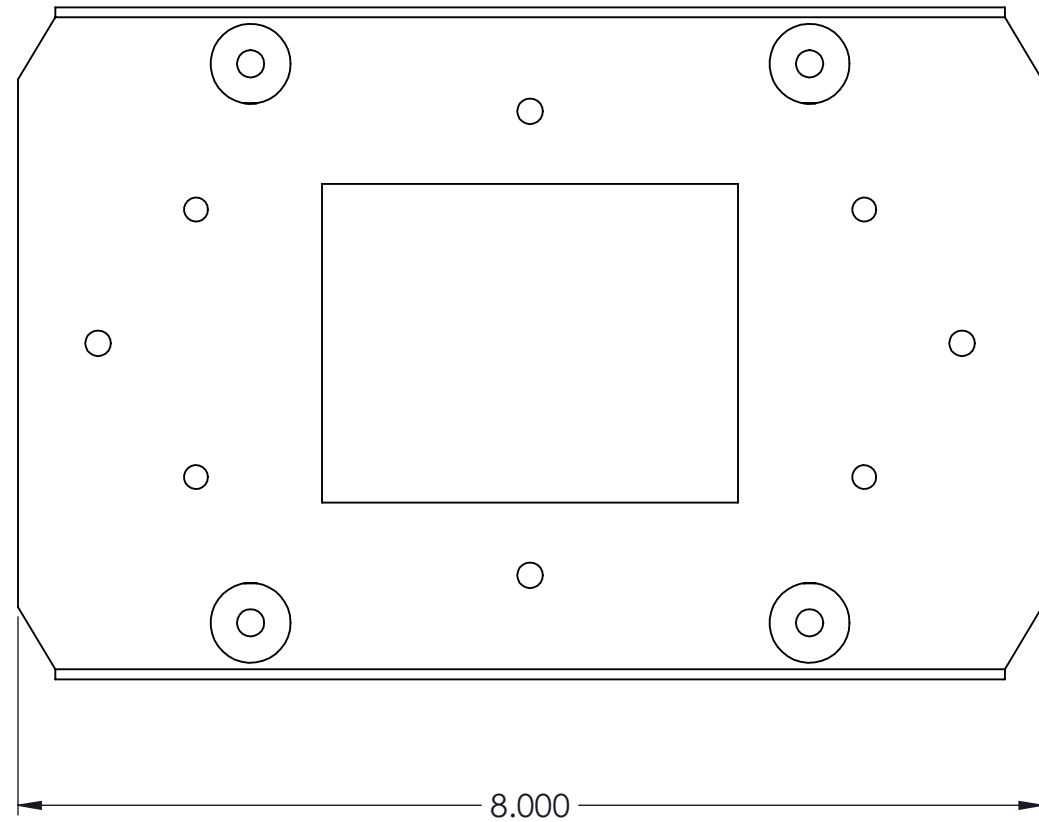
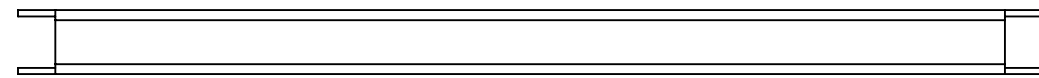

TOLERANCES UNLESS OTHERWISE NOTED XXX ± .015 XX ± .030 HOLE ± .005 ANGLE ± 1°	 <b>AMD Industries Inc.</b> 4620 West 19th Street, Cicero, IL 60804		
	<b>TITLE</b> TURNTABLE BRACKET		
<b>DESIGNED</b> JB	<b>DRAWN</b> JB	<b>MATERIAL</b> 18 GA (.048) CRS	<b>PART NO</b> PXXXXX
<b>DATE</b> 12/07/17	<b>DATE</b> 12/20/17	<b>FINISH</b> BLACK MINI TEX	<b>SHEET 1 OF 2</b>

REV	ECN #	DESCRIPTION	DATE	BY
1	XXX	DESIGN INTENT FOR ENGINEERING	12/20/17	JB

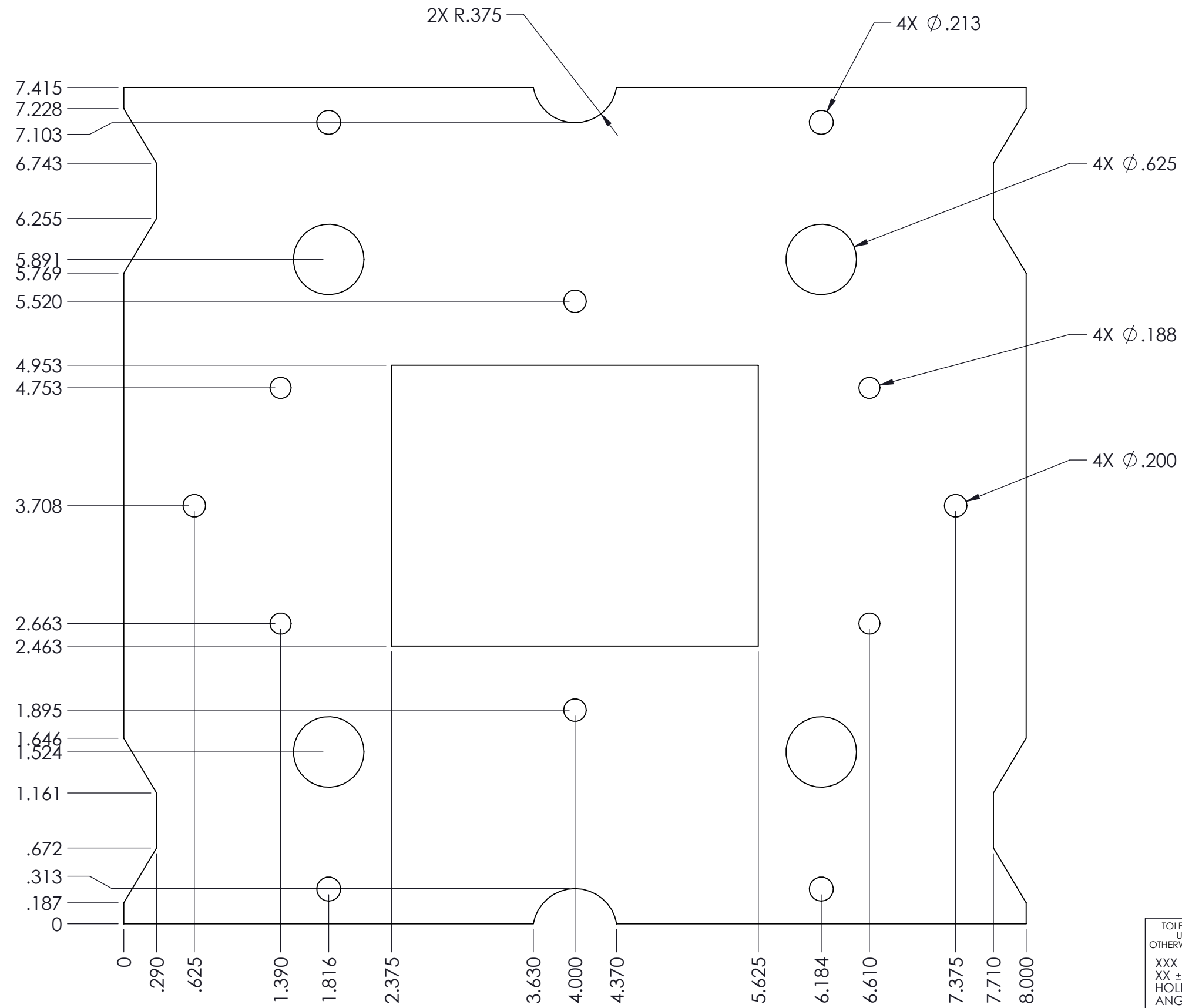

TOLERANCES UNLESS OTHERWISE NOTED XXX $\pm$ .015 XX $\pm$ .030 HOLE $\pm$ .005 ANGLE $\pm$ 1°	 AMD Industries Inc. 4620 West 19th Street, Cicero, IL 60804		
	TITLE TURNTABLE BRACKET		
DESIGNED JB	DRAWN JB	MATERIAL 18 GA (.048) CRS	PART NO PXXXXX
DATE 12/07/17	DATE 12/20/17	FINISH BLACK MINI TEX	SHEET 2 OF 2



REV	ECN #	DESCRIPTION	DATE	BY
1	XXX	DESIGN INTENT FOR ENGINEERING	12/20/17	JB

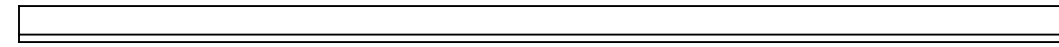

ENSURE CORRECT  
ORIENTATION  
BEFORE BENDING

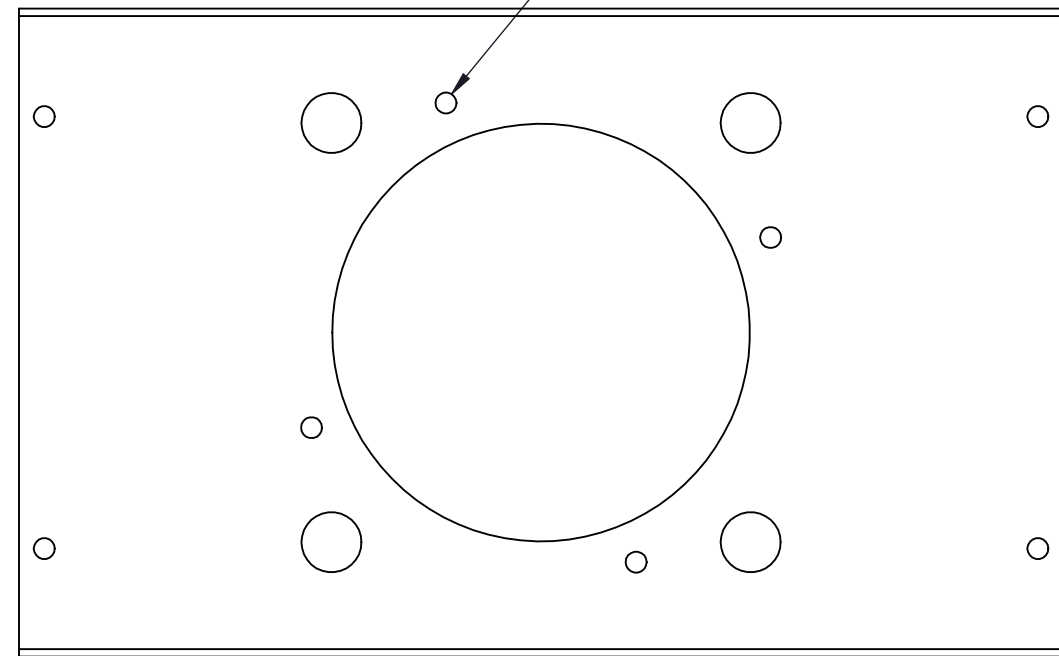

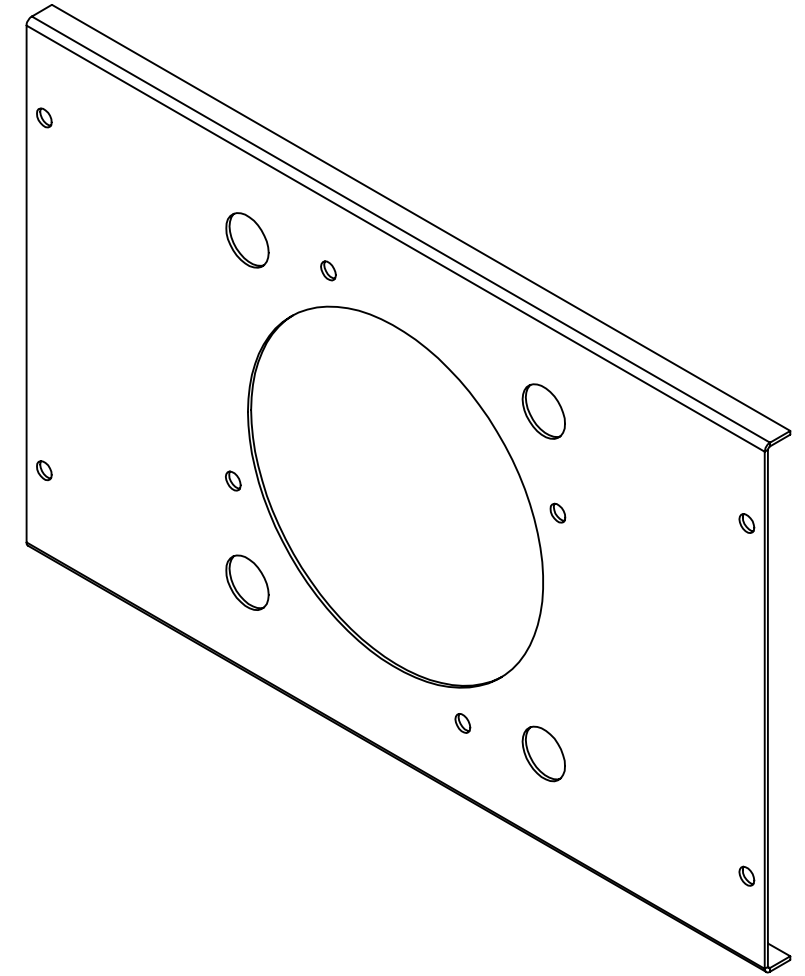
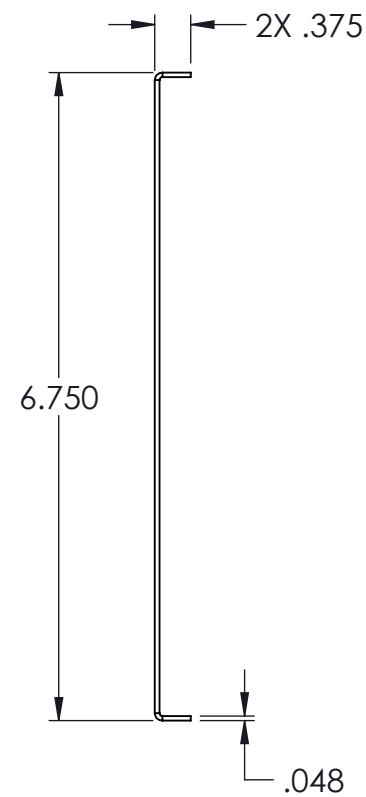

10.875

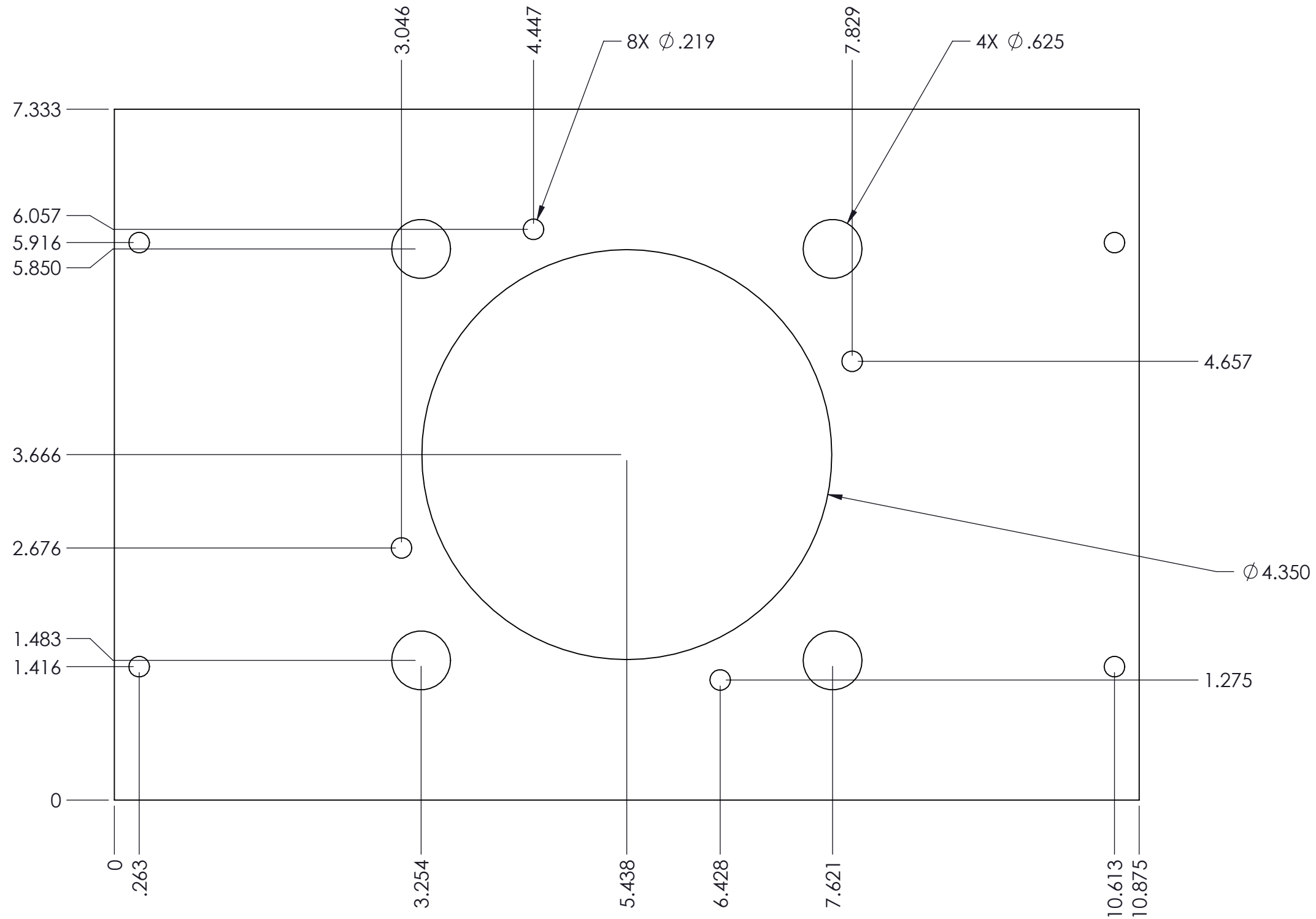

TOLERANCES UNLESS OTHERWISE NOTED XXX ± .015 XX ± .030 HOLE ± .005 ANGLE ± 1°	 AMD Industries Inc. 4620 West 19th Street, Cicero, IL 60804		
	TITLE FIXED TURNTABLE BRACKET		
DESIGNED JB	DRAWN JB	MATERIAL 18 GA (.048) CRS	PART NO PXXXXX
DATE 12/11/17	DATE 12/20/17	FINISH XXXXXXXXXX	SHEET 1 OF 2

REV	ECN #	DESCRIPTION	DATE	BY
1	XXX	DESIGN INTENT FOR ENGINEERING	12/20/17	JB



TOLERANCES UNLESS OTHERWISE NOTED XXX ± .015 XX ± .030 HOLE ± .005 ANGLE ± 1°	 AMD Industries Inc. 4620 West 19th Street, Cicero, IL 60804		
	TITLE FIXED TURNTABLE BRACKET		
DESIGNED JB	DRAWN JB	MATERIAL 18 GA (.048) CRS	PART NO PXXXXX
DATE 12/11/17	DATE 12/20/17	FINISH XXXXXXXXXX	SHEET 2 OF 2

REV	ECN #	DESCRIPTION	DATE	BY
1	XXX	DESIGN INTENT FOR ENGINEERING	12/20/17	JB

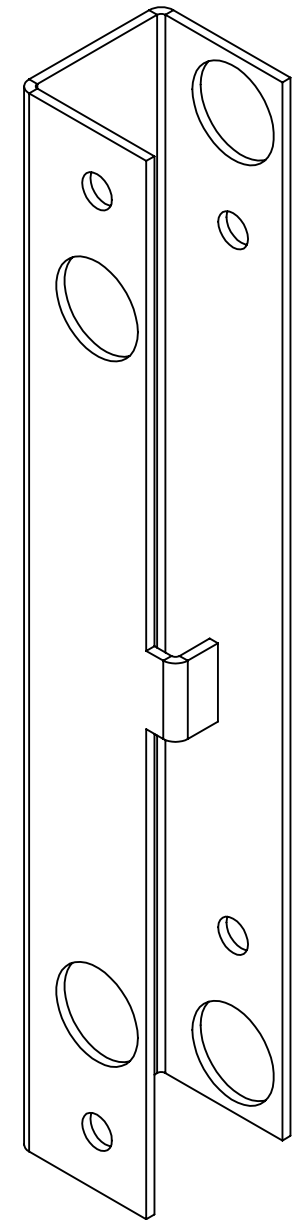
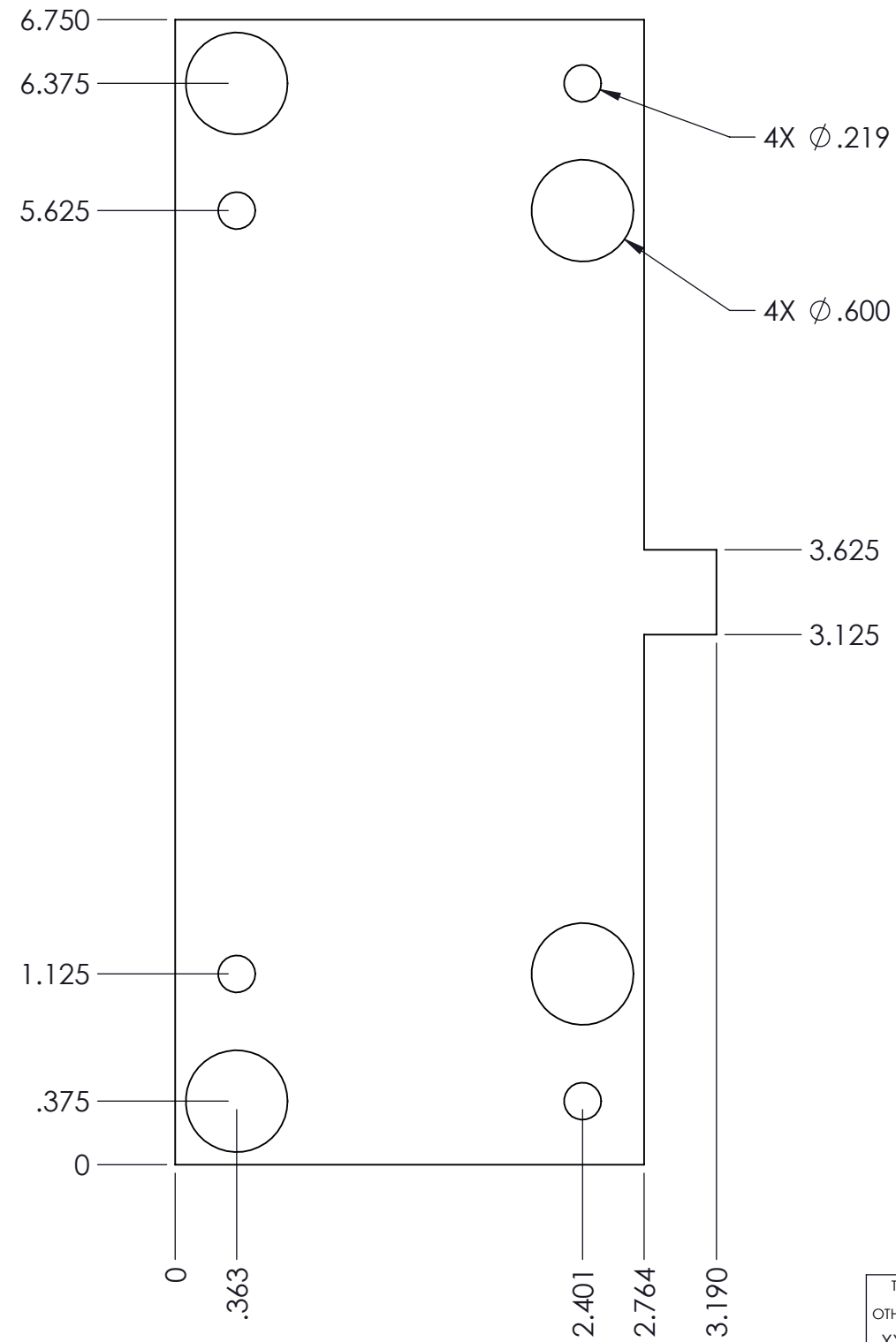
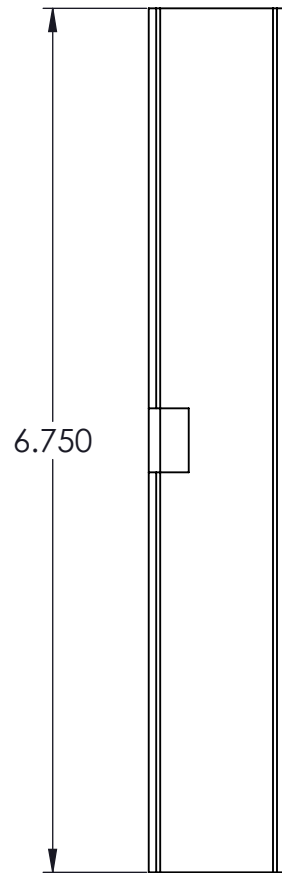
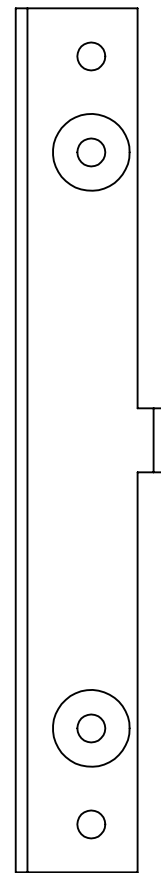
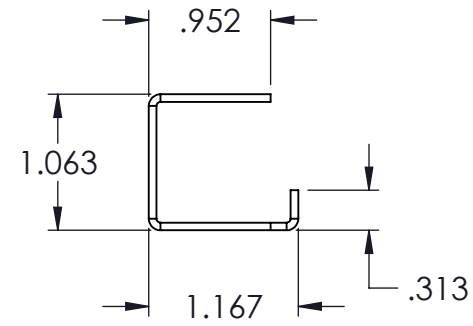

TOLERANCES UNLESS OTHERWISE NOTED XXX $\pm$ .015 XX $\pm$ .030 HOLE $\pm$ .005 ANGLE $\pm$ 1°	 AMD Industries Inc. 4620 West 19th Street, Cicero, IL 60804		PART NO PXXXXX
	TITLE BRACKET		
DESIGNED JB	DRAWN JB	MATERIAL 16 GA (.060) CRS	SHEET 1 OF 1
DATE 12/10/17	DATE 12/20/17	FINISH XXXXXXXXXX	

REV	ECN #	DESCRIPTION	DATE	BY
1	XXX	DESIGN INTENT FOR ENGINEERING	12/20/17	JB

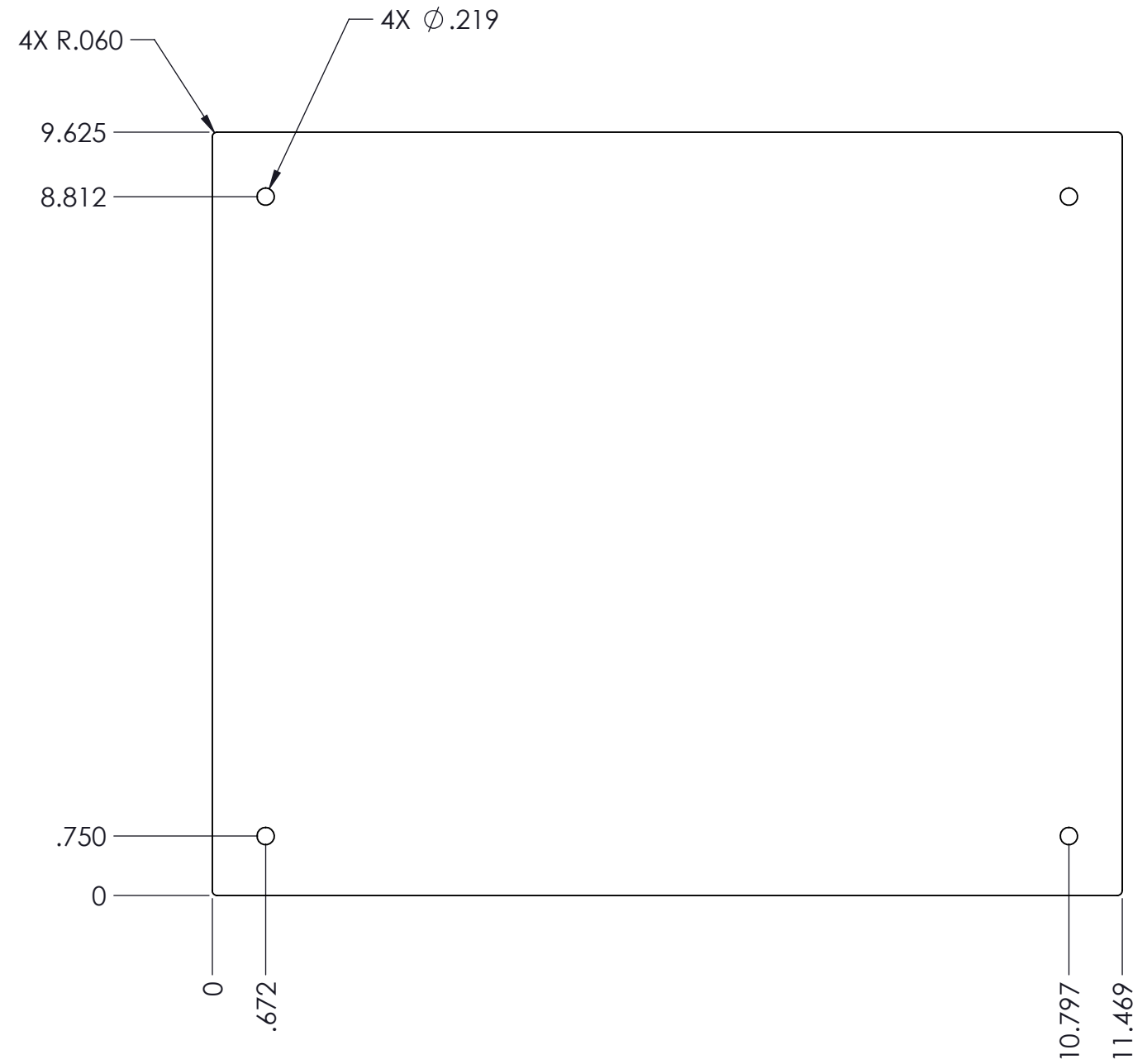
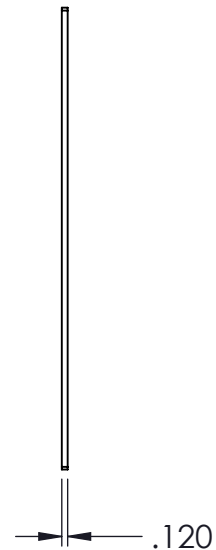
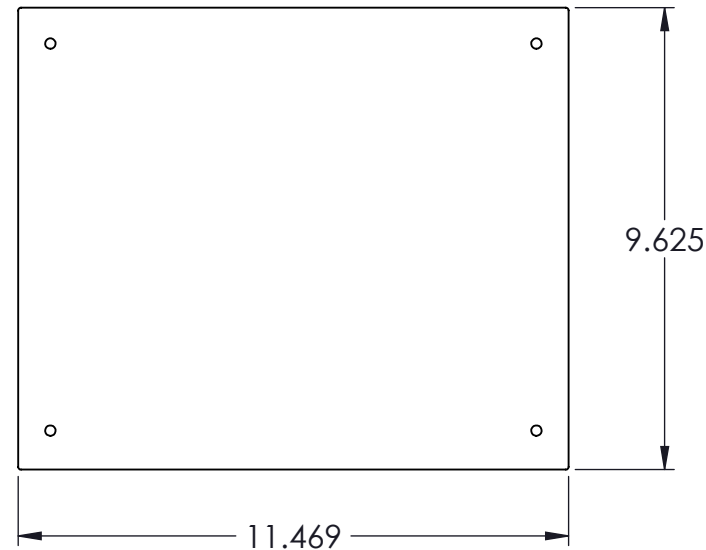
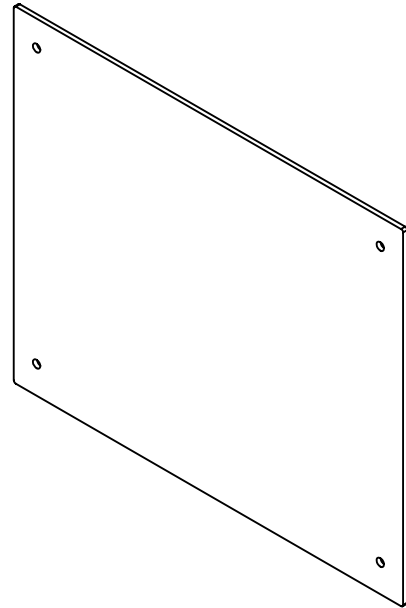

TOLERANCES UNLESS OTHERWISE NOTED XXX $\pm$ .015 XX $\pm$ .030 HOLE $\pm$ .005 ANGLE $\pm$ 1°	 AMD Industries Inc. 4620 West 19th Street, Cicero, IL 60804		
	TITLE BOTTOM COVER		
DESIGNED JB	DRAWN JB	MATERIAL 11 GA (.120) CRS	PART NO PXXXXX
DATE 12/08/17	DATE 12/20/17	FINISH BLACK MINI TEX	SHEET 1 OF 1

REV	ECN #	DESCRIPTION	DATE	BY
1	XXX	DESIGN INTENT FOR ENGINEERING	12/20/17	JB

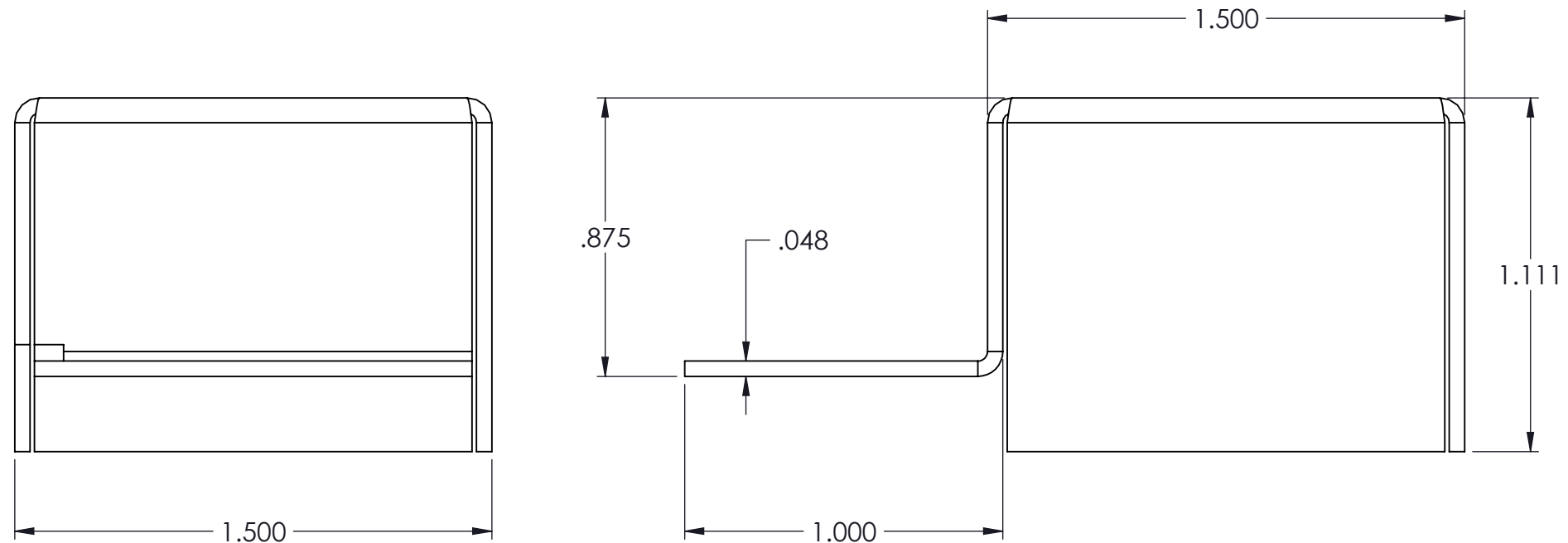
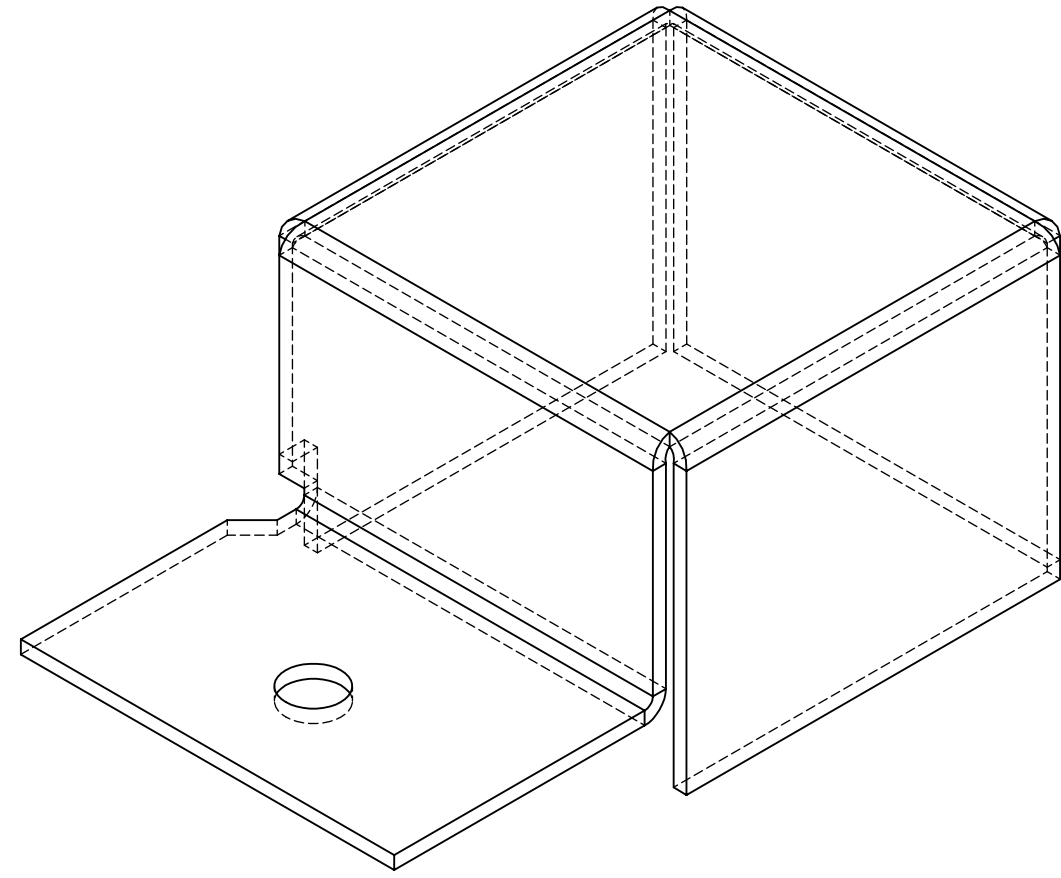
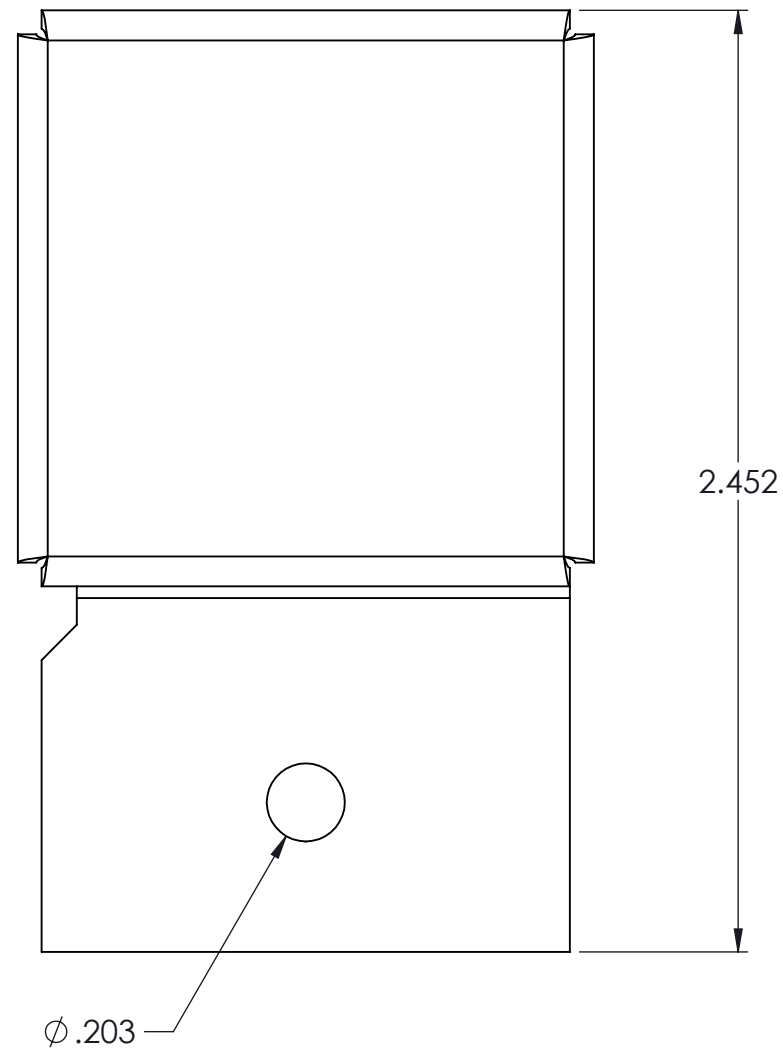

TOLERANCES UNLESS OTHERWISE NOTED XXX ± .015 XX ± .030 HOLE ± .005 ANGLE ± 1°	 <b>AMD Industries Inc.</b> 4620 West 19th Street, Cicero, IL 60804		
	<b>TITLE</b> LED LIGHT BOX		
DESIGNED	DRAWN JB	MATERIAL 18 GA (.048) CRS	PART NO PXXXXX
DATE	DATE 12/20/17	FINISH WW WHITE	SHEET 1 OF 2

REV	ECN #	DESCRIPTION	DATE	BY
1	XXX	DESIGN INTENT FOR ENGINEERING	12/20/17	JB

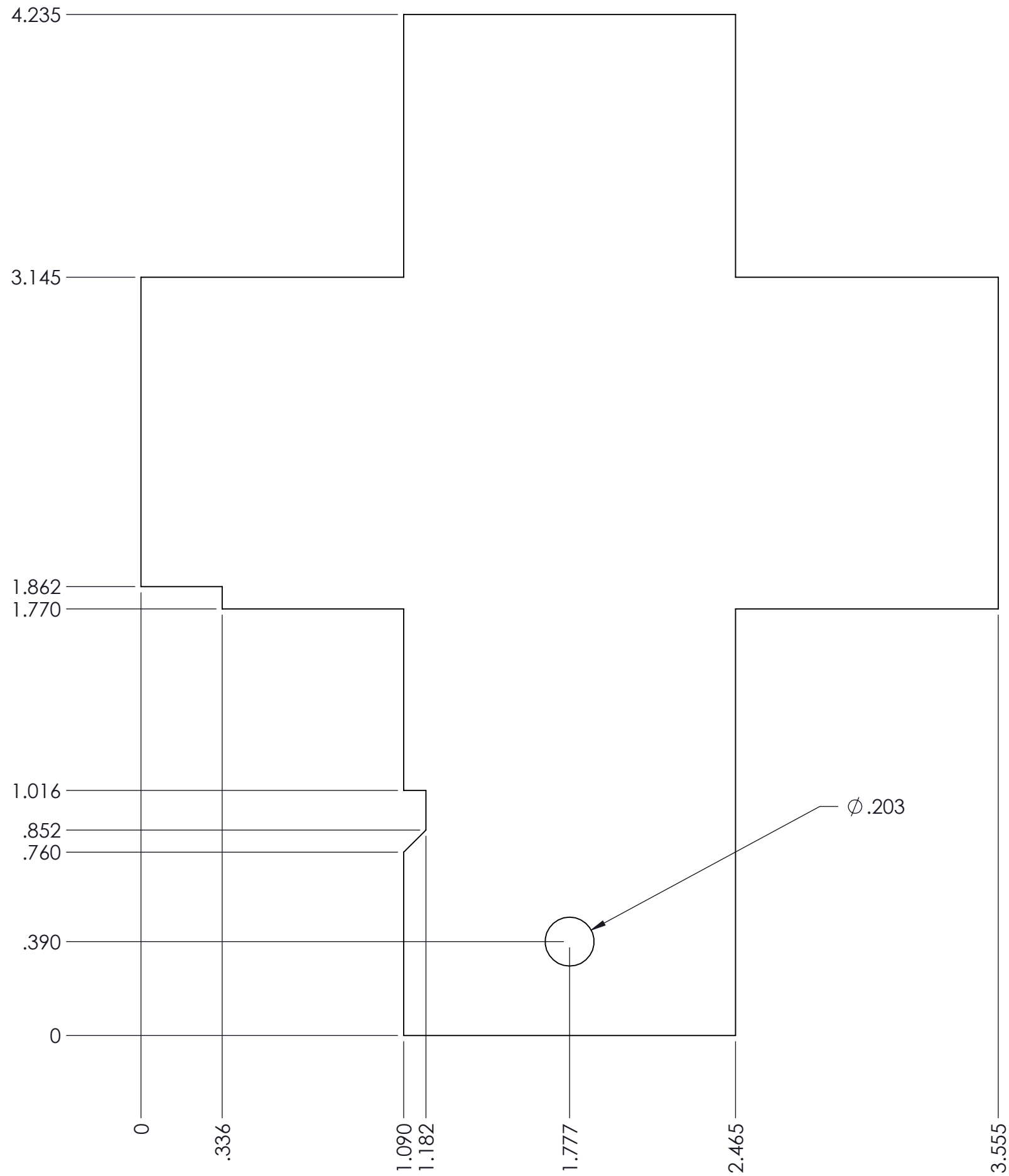

TOLERANCES UNLESS OTHERWISE NOTED XXX ± .015 XX ± .030 HOLE ± .005 ANGLE ± 1°	 AMD Industries Inc. 4620 West 19th Street, Cicero, IL 60804		
	TITLE LED LIGHT BOX		
DESIGNED	DRAWN JB	MATERIAL 18 GA (.048) CRS	PART NO PXXXXX
DATE	DATE 12/20/17	FINISH WW WHITE	SHEET 2 OF 2

REV	ECN #	DESCRIPTION	DATE	BY
1	XXX	DESIGN INTENT FOR ENGINEERING	12/20/17	JB

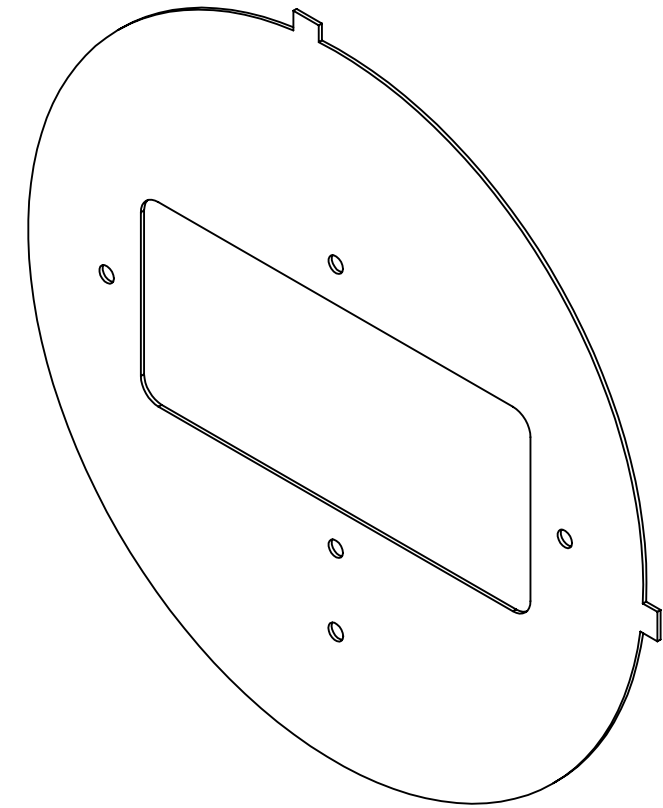
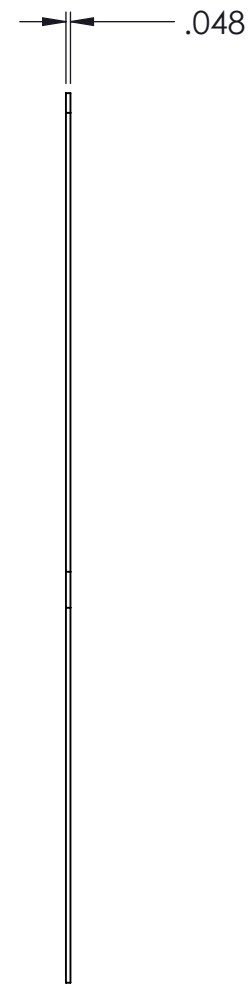
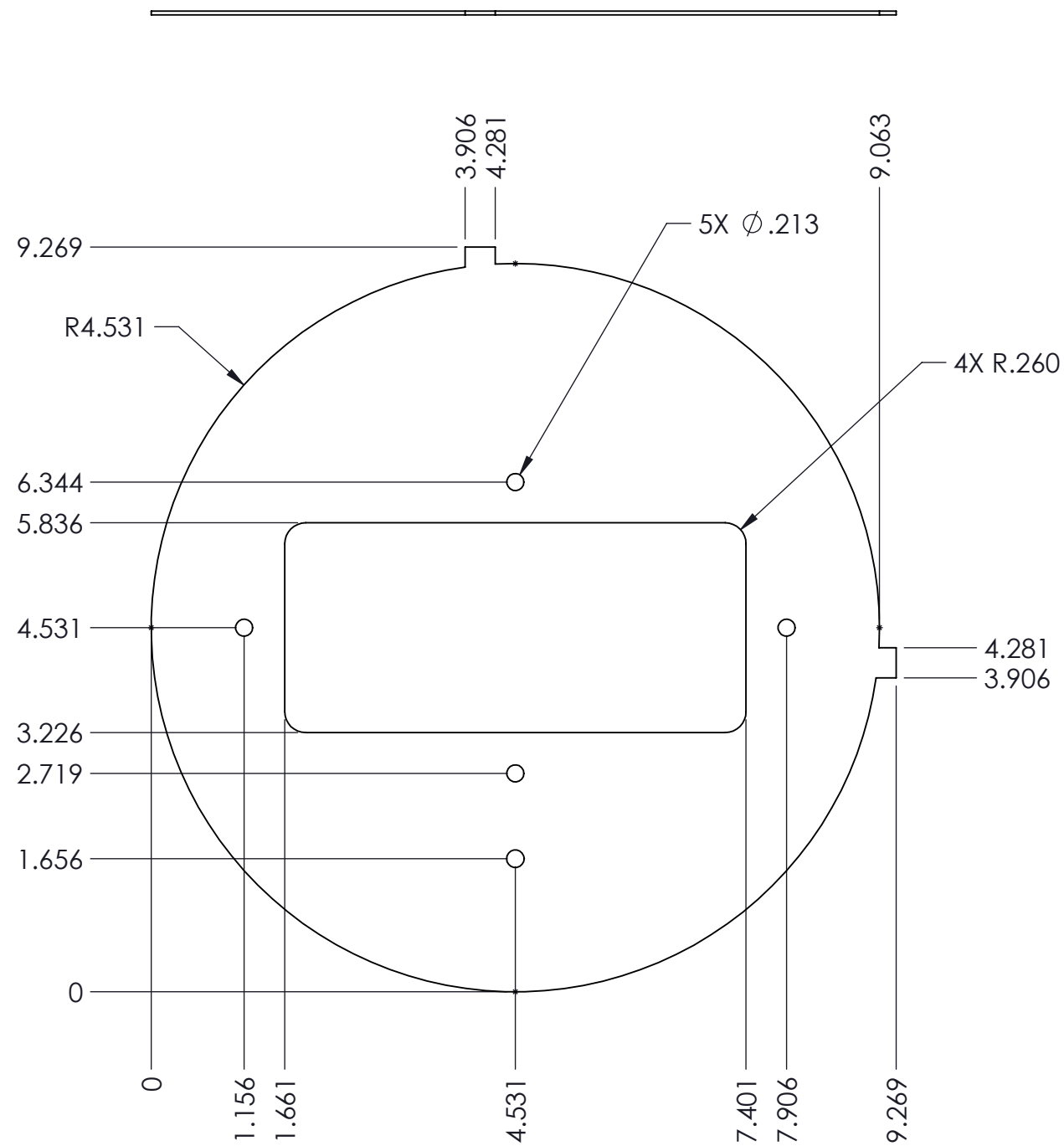

TOLERANCES UNLESS OTHERWISE NOTED XXX ± .015 XX ± .030 HOLE ± .005 ANGLE ± 1°	 AMD Industries Inc. 4620 West 19th Street, Cicero, IL 60804		
	TITLE <b>ROTATING BRACKET WITH TABS</b>		
DESIGNED JB	DRAWN JB	MATERIAL 18 GA (.048) CRS	PART NO PXXXXX
DATE 12/13/17	DATE 12/20/17	FINISH XXXXXXXXXX	SHEET 1 OF 1

REV	ECN #	DESCRIPTION	DATE	BY
1	XXX	DESIGN INTENT FOR ENGINEERING	12/20/17	JB

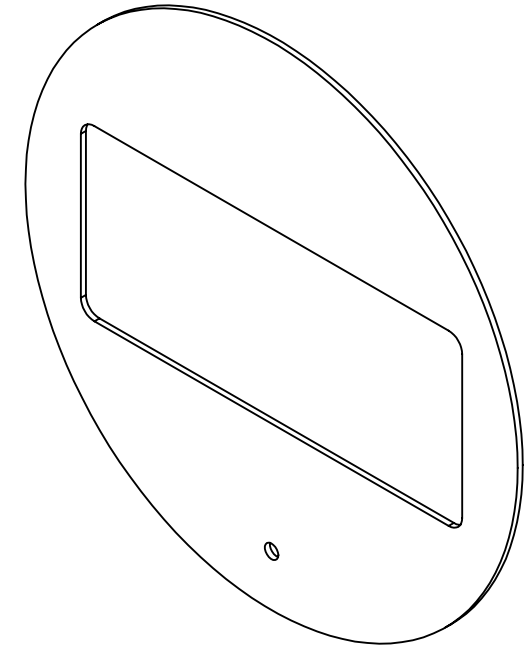
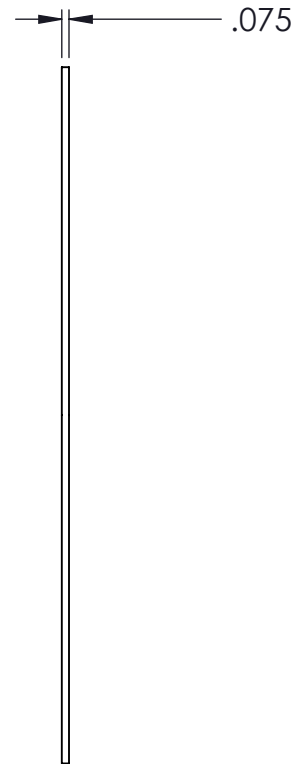
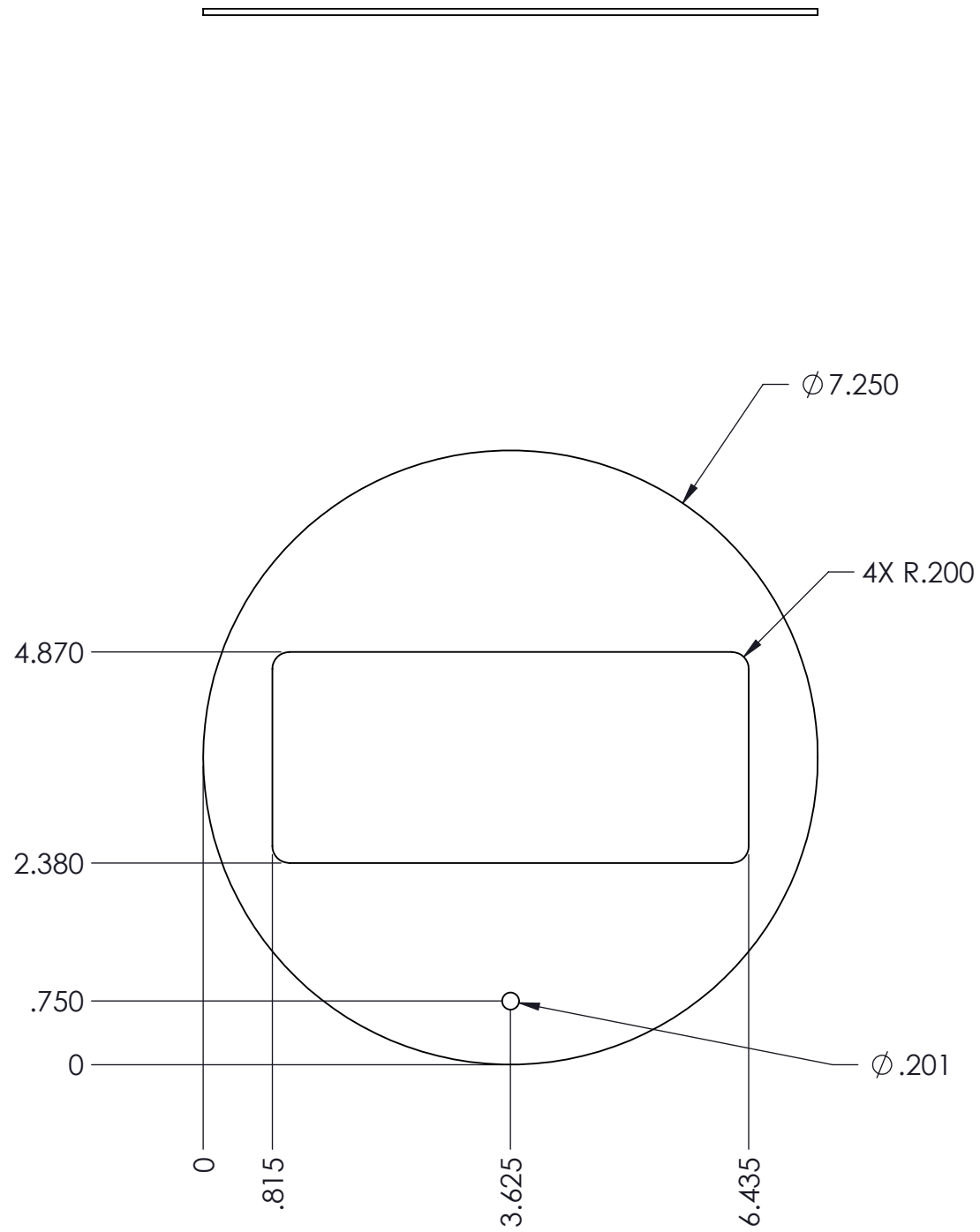

NOTE:  
SEE NEXT PAGE FOR INK  
TRANSFER DIRECTION

TOLERANCES UNLESS OTHERWISE NOTED XXX ± .015 XX ± .030 HOLE ± .005 ANGLE ± 1°	 AMD Industries Inc. 4620 West 19th Street, Cicero, IL 60804		
	TITLE SAM UNIT BEZEL		
DESIGNED JB	DRAWN JB	MATERIAL 14 GA (.075) CRS	PART NO PXXXXX
DATE 12/11/17	DATE 12/20/17	FINISH BLACK MINI TEX	SHEET 1 OF 2



REV	ECN #	DESCRIPTION	DATE	BY
1	XXX	DESIGN INTENT FOR ENGINEERING	12/20/17	JB



- NOTES:  
 APPLY INK TRANSFER AFTER PAINTING
- USED ARTWORK PROVIDED
  - 1 COLOR WHITE INK TRANSFER
  - STANDARD DURATAG WITH BLEND 21 ACTIVATOR TO ADHERE TO BLACK MINI TEX POWDERCOATED METAL

TOLERANCES UNLESS OTHERWISE NOTED  XXX ± .015 XX ± .030 HOLE ± .005 ANGLE ± 1°	 AMD Industries Inc. 4620 West 19th Street, Cicero, IL 60804		PART NO PXXXXX
	TITLE SAM UNIT BEZEL		
DESIGNED JB	DRAWN JB	MATERIAL 14 GA (.075) CRS	SHEET 2 OF 2
DATE 12/11/17	DATE 12/20/17	FINISH BLACK MINI TEX	

REV	ECN #	DESCRIPTION	DATE	BY
1	XXX	DESIGN INTENT FOR ENGINEERING	12/20/17	JB

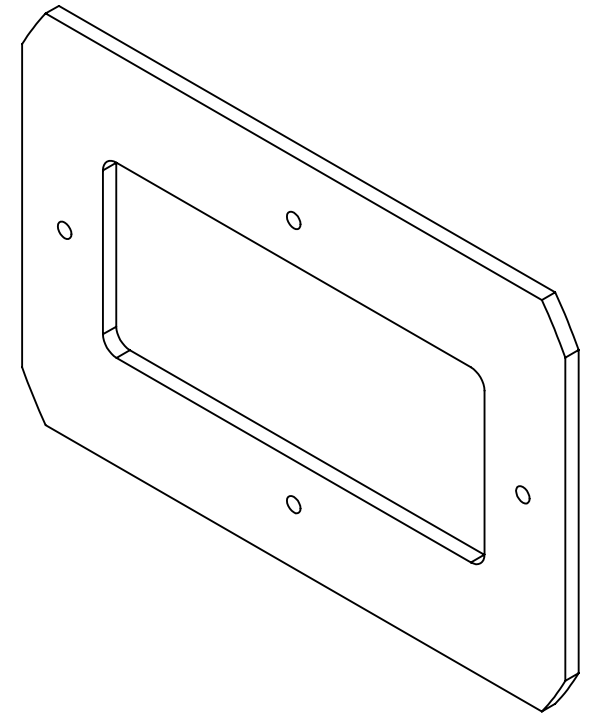
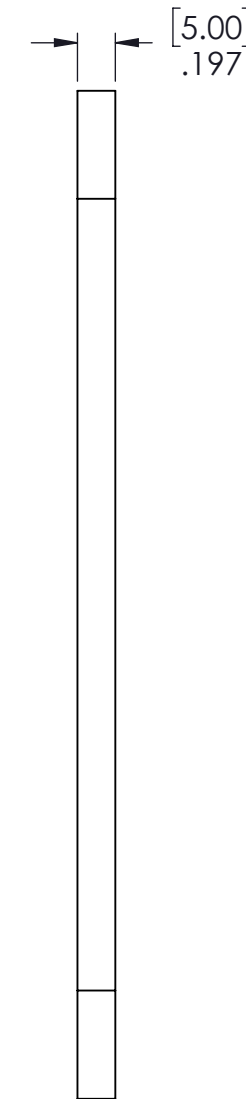
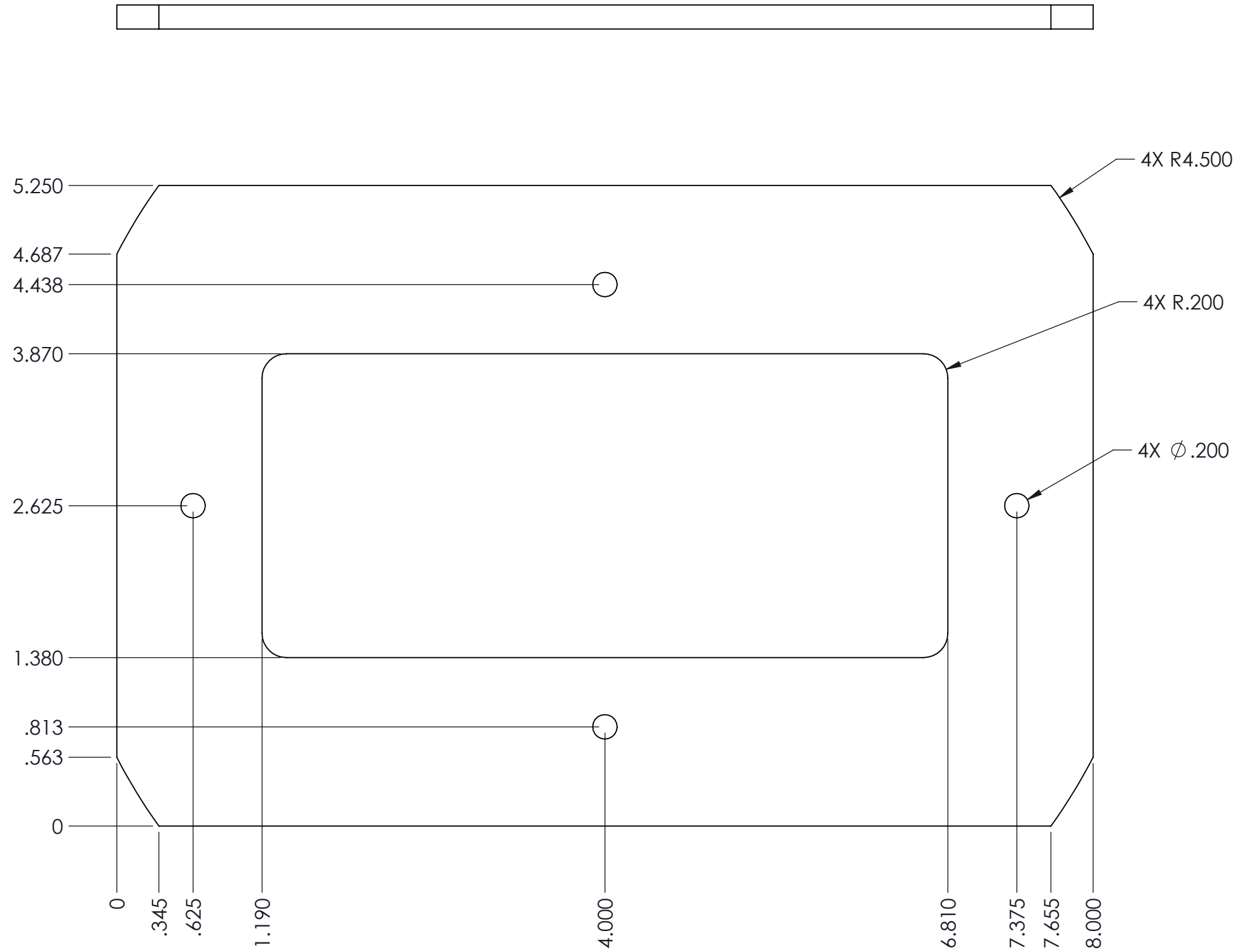

TOLERANCES UNLESS OTHERWISE NOTED XXX $\pm$ .015 XX $\pm$ .030 HOLE $\pm$ .005 ANGLE $\pm$ 1°		 AMD Industries Inc. 4620 West 19th Street, Cicero, IL 60804	
DESIGNED JB		TITLE SPACER	
DATE 12/11/17	DRAWN JB	MATERIAL SINTRA	PART NO PXXXXX
DATE 12/20/17		FINISH BLACK	SHEET 1 OF 1

REV	ECN #	DESCRIPTION	DATE	BY
1	XXX	DESIGN INTENT FOR ENGINEERING	12/20/17	JB

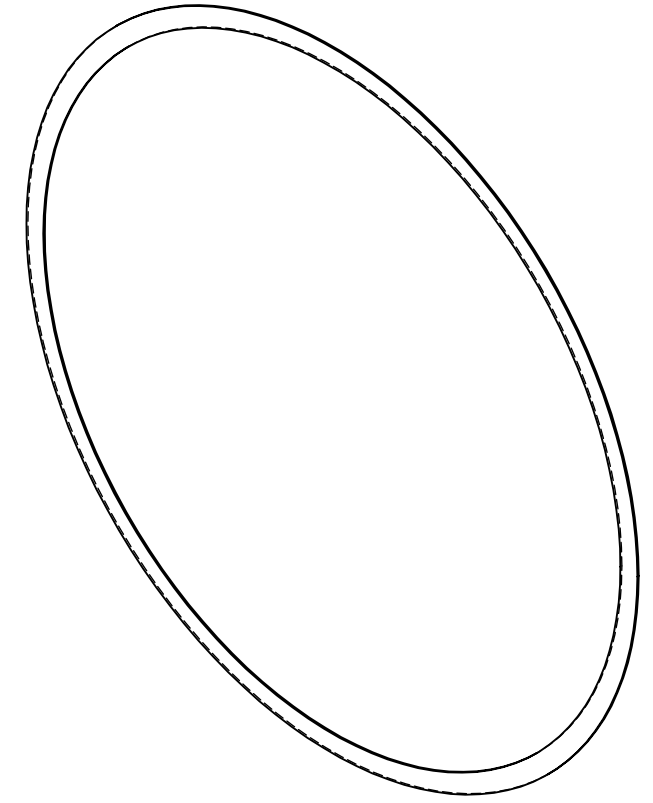
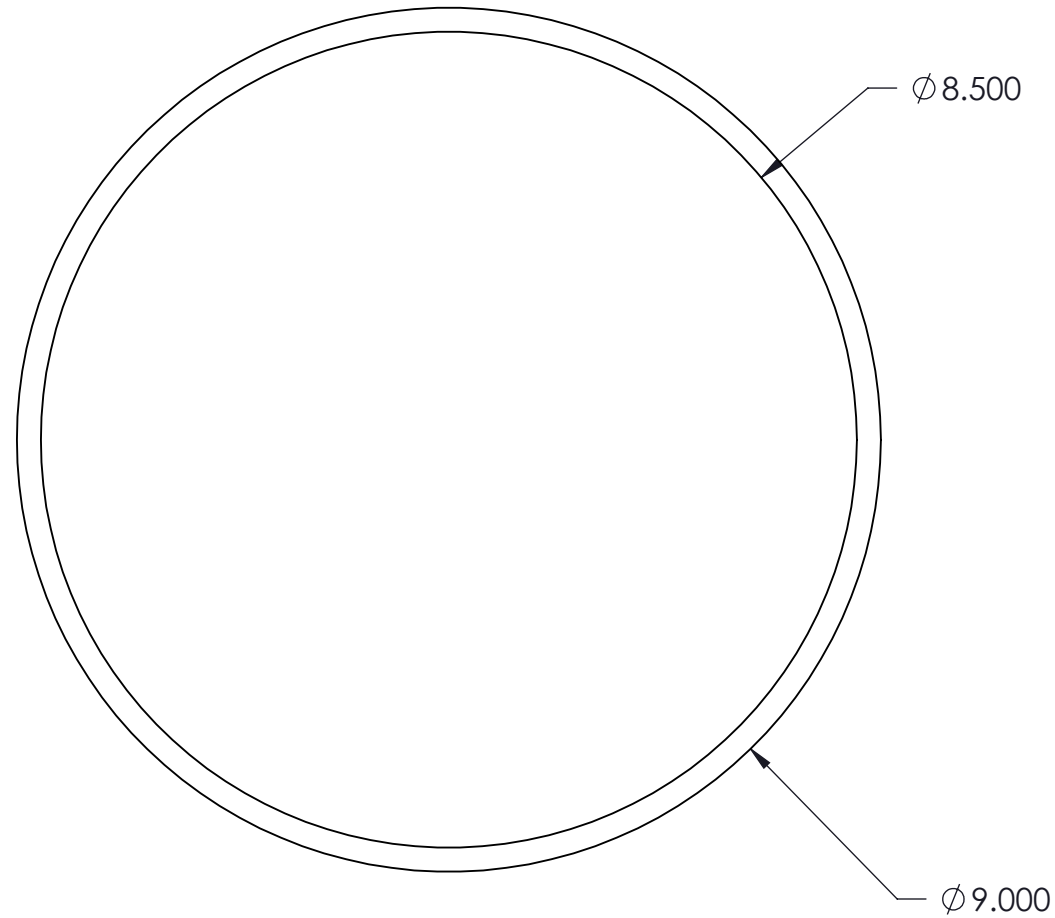

NOTES:  
BLACK 0.020" STYRENE WITH  
FULL ADHESIVE BACKING

TOLERANCES UNLESS OTHERWISE NOTED XXX ± .015 XX ± .030 HOLE ± .005 ANGLE ± 1°	 AMD Industries Inc. 4620 West 19th Street, Cicero, IL 60804		
	TITLE BLACK STYRENE WITH FULL BACK ADHESIVE		
DESIGNED JB	DRAWN JB	MATERIAL STYRENE	PART NO PXXXXX
DATE 12/11/17	DATE 12/20/17	FINISH BLACK WITH FULL BACK ADHESIVE	SHEET 1 OF 1

REV	ECN #	DESCRIPTION	DATE	BY
1	XXX	DESIGN INTENT FOR ENGINEERING	12/20/17	JB

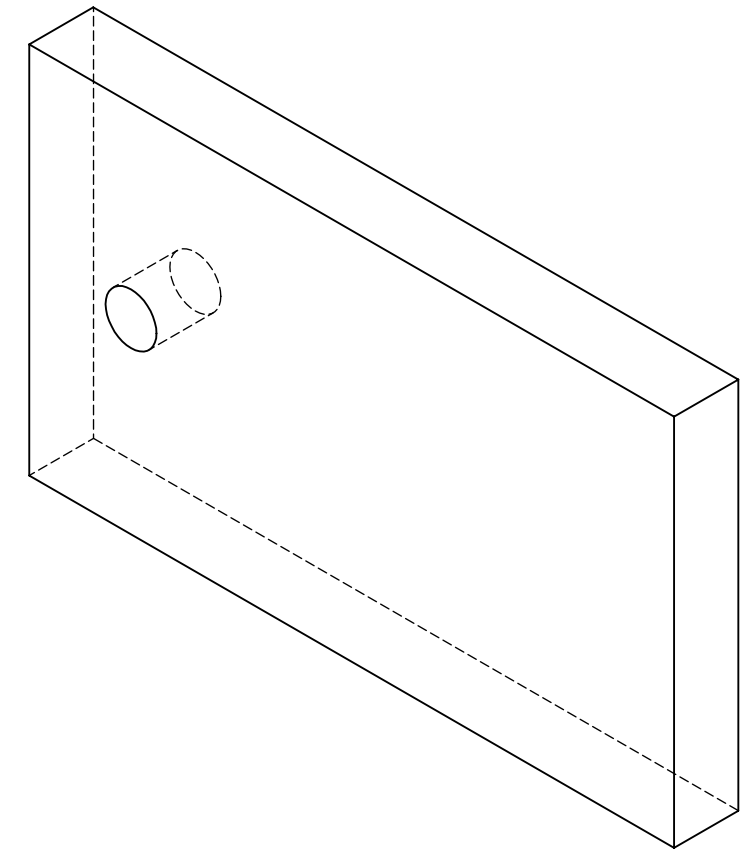
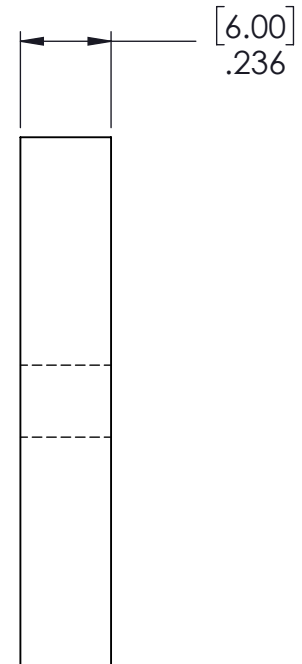
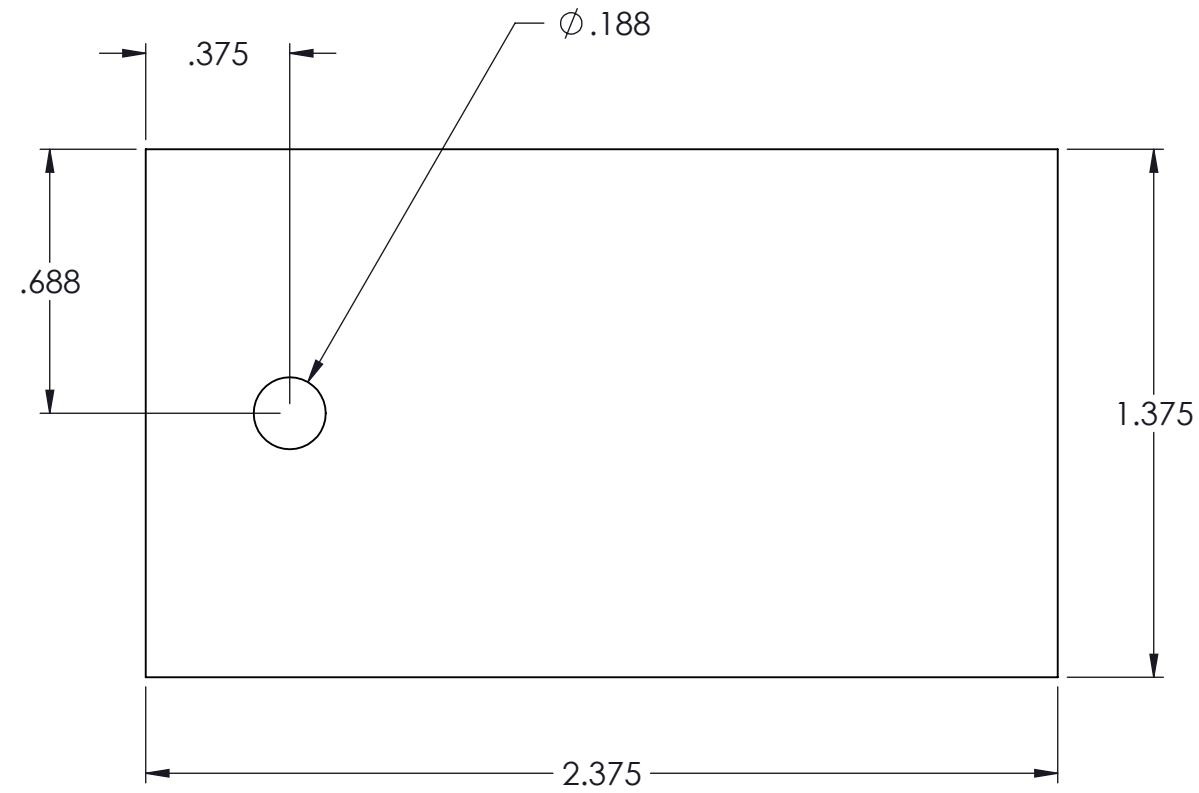

2051 BLUE TRANSLUCENT ACRYLIC

TOLERANCES UNLESS OTHERWISE NOTED XXX ± .015 XX ± .030 HOLE ± .005 ANGLE ± 1°	 AMD Industries Inc. 4620 West 19th Street, Cicero, IL 60804		PART NO PXXXXX
	TITLE ACRYLIC LOGO BACKER		
DESIGNED JB	DRAWN JB	MATERIAL ACRYLIC	SHEET 1 OF 1
DATE 12/13/17	DATE 12/20/17	FINISH XXXXXXXXXX	

REV	ECN #	DESCRIPTION	DATE	BY
1	XXX	DESIGN INTENT FOR ENGINEERING	12/20/17	JB

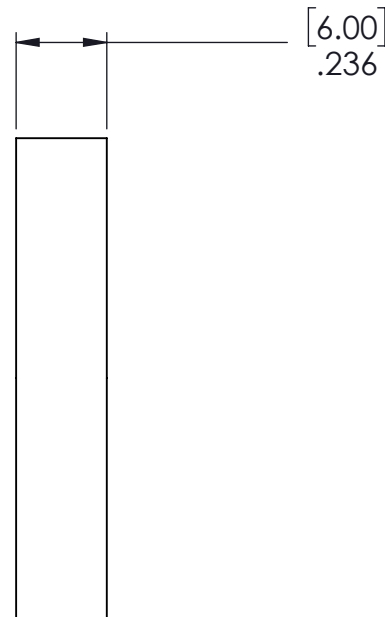
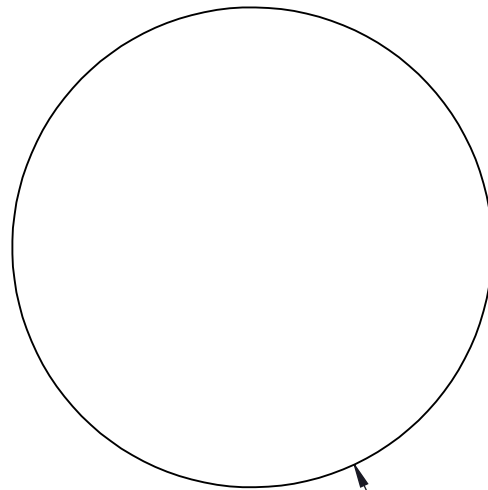
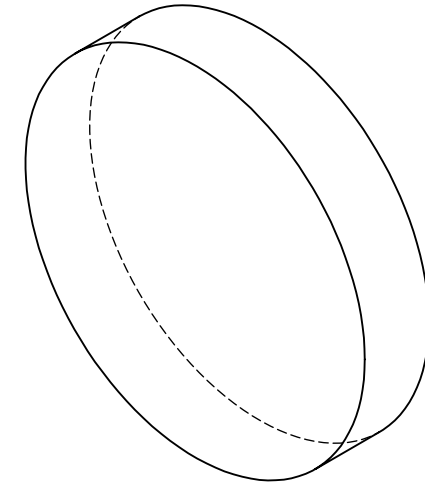

$\phi 1.250^{+.000}_{-.031}$

2051 BLUE TRANSLUCENT ACRYLIC

NOTE:  
MUST BE LASER CUT (OR SIMILAR CLEAN EDGES)

TOLERANCES UNLESS OTHERWISE NOTED XXX ± .015 XX ± .030 HOLE ± .005 ANGLE ± 1°	 AMD Industries Inc. 4620 West 19th Street, Cicero, IL 60804		PART NO PXXXXX
	TITLE ACRYLIC LOGO CIRCLE		
DESIGNED JB	DRAWN JB	MATERIAL ACRYLIC	SHEET 1 OF 1
DATE 12/13/17	DATE 12/20/17	FINISH XXXXXXXXXX	

REV	ECN #	DESCRIPTION	DATE	BY
1	XXX	DESIGN INTENT FOR ENGINEERING	12/20/17	JB

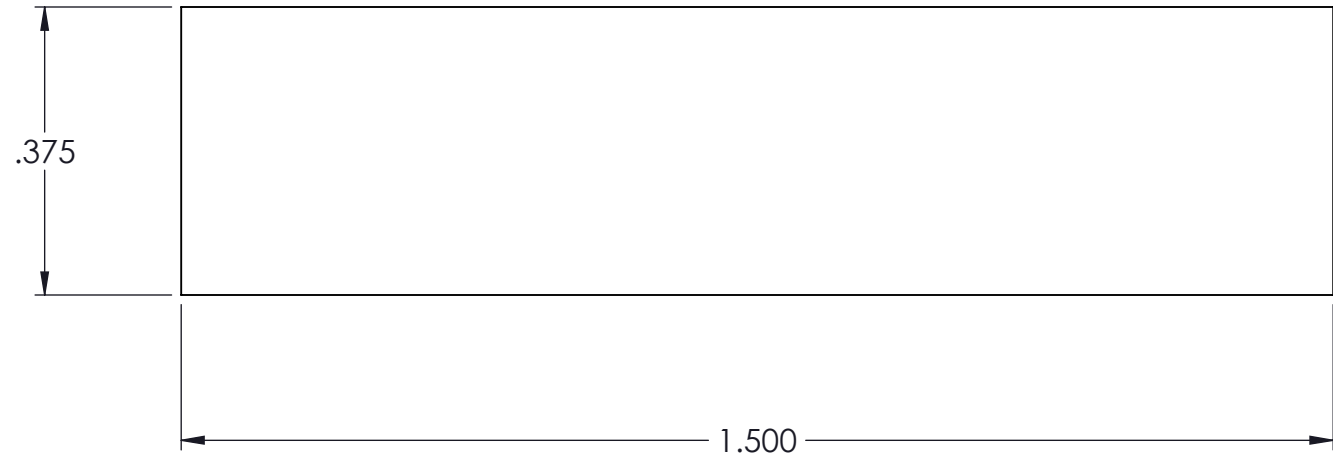
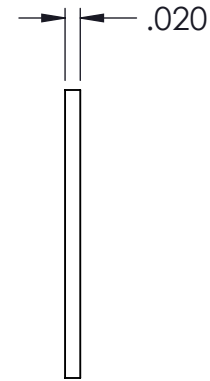
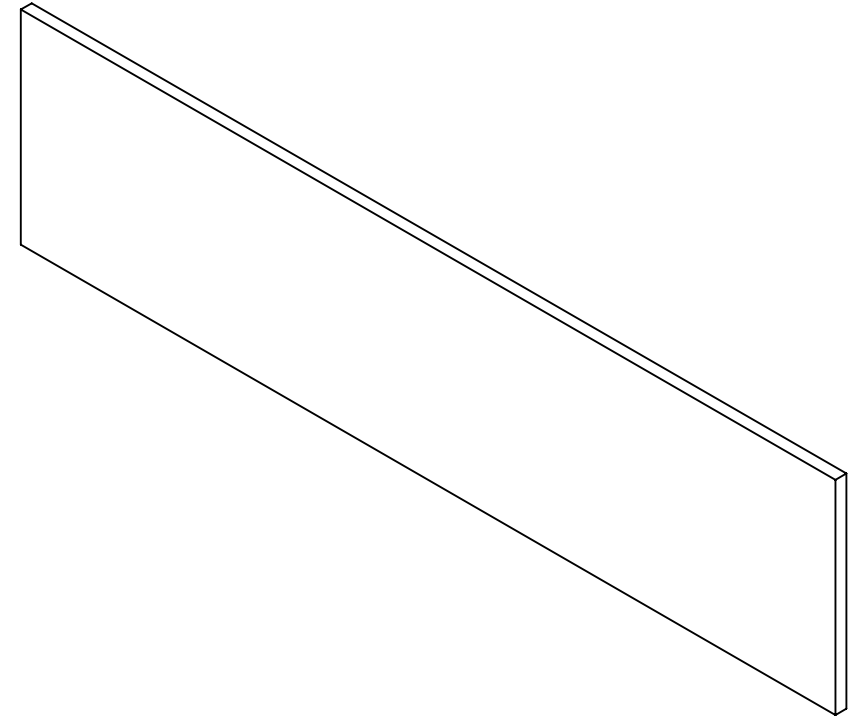
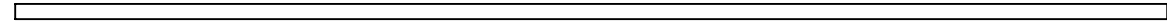

TOLERANCES UNLESS OTHERWISE NOTED XXX ± .015 XX ± .030 HOLE ± .005 ANGLE ± 1°	 AMD Industries Inc. 4620 West 19th Street, Cicero, IL 60804		
	TITLE TWINSTICK 0.020" X 1.5" X .375"		
DESIGNED JB	DRAWN JB	MATERIAL ACRYLIC	PART NO PXXXXX
DATE 12/12/17	DATE 12/20/17	FINISH XXXXXXXXXX	SHEET 1 OF 1