

REV	ECN #	DESCRIPTION	DATE	BY
1	XXXX	FOR PRICING	08/12/19	JB

9 PAGE ENGINEERING BINDER FOR PRICING

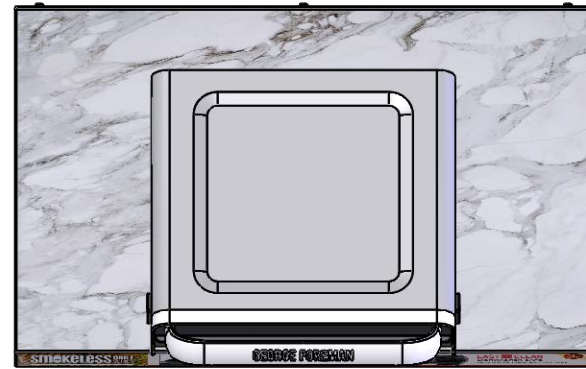

24.000

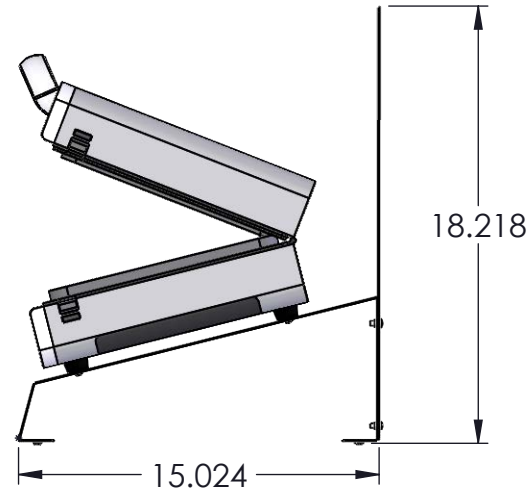

TOLERANCES UNLESS OTHERWISE NOTED XXX ± .015 XX ± .030 HOLE ± .005 ANGLE ± 1°		TITLE GEORGE FOREMAN GRD6090B COSTCO	
DESIGNED JB	DRAWN JB	MATERIAL N/A	PART NO PXXXXX
DATE 08/12/19	DATE 08/12/19	FINISH N/A	SHEET 1 OF 2

REV	ECN #	DESCRIPTION	DATE	BY
1	XXXX	FOR PRICING	08/12/19	JB

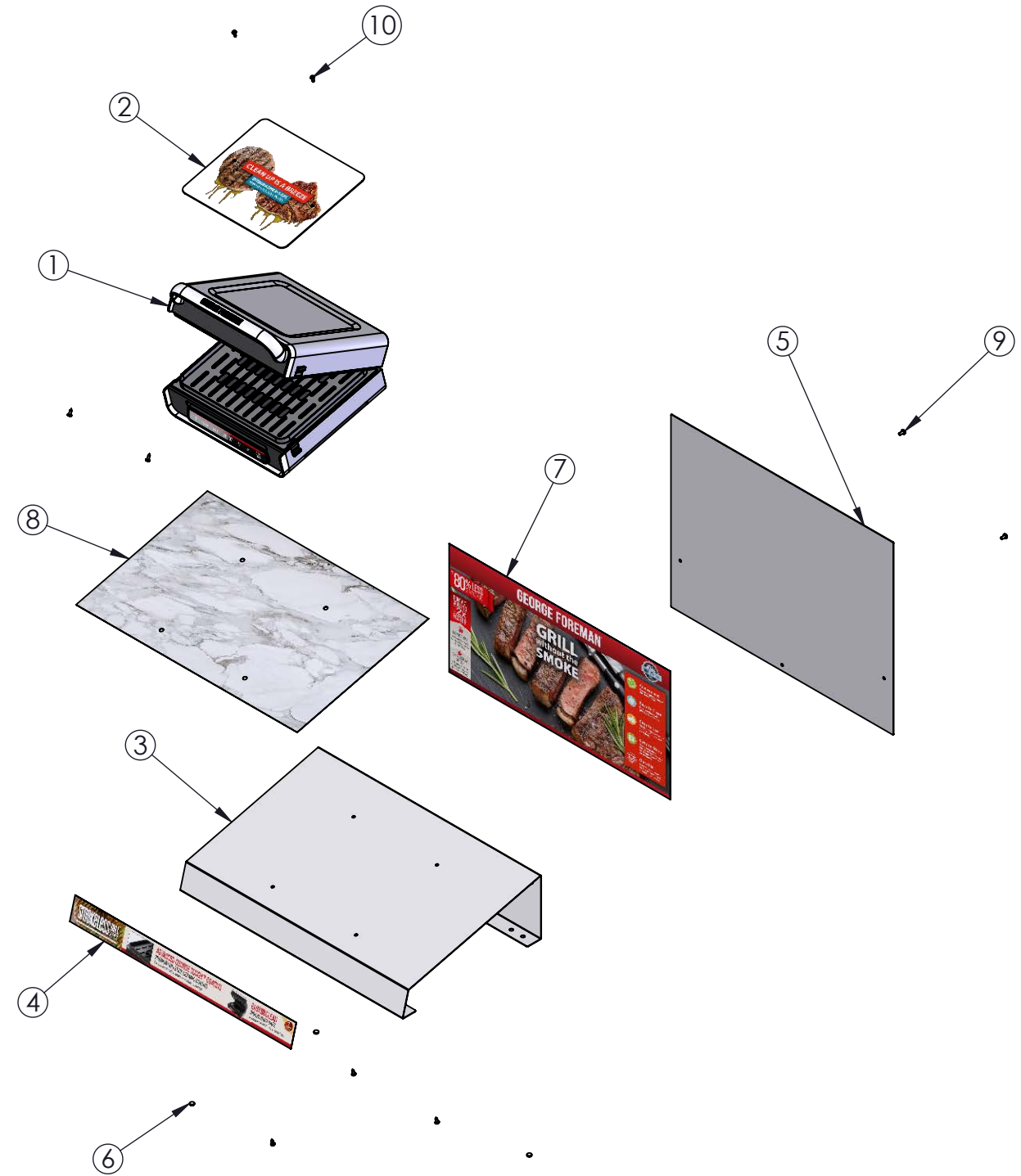

10	P36740	SHEET METAL SCREW 8 X 1/2 PHILLIP PAN HEAD TYPE B BLACK OXIDE	8
9	P12076	MACHINE SCREW 10-24 X 3/8 PHILLIP PAN HEAD ZINC	3
8	PXXXXX	GRAPHIC PLATFORM COSTCO	1
7	PXXXXX	GRAPHIC BACKER COSTCO	1
6	PXXXXX	CLEAR RUBBER BUMPERS 1/2" DIAM X 0.14" THICK	4
5	PXXXXX	BACK	1
4	PXXXXX	GRAPHIC FRONT COSTCO	1
3	PXXXXX	BASE SUB-ASSEMBLY	1
2	PXXXXX	GRAPHIC ON GRILL 1	1
1	PXXXXX	George Foreman Grill GRD6090B	1
ITEM NO.	PART NO.	DESCRIPTION	QTY.

TOLERANCES UNLESS OTHERWISE NOTED XXX ± .015 XX ± .030 HOLE ± .005 ANGLE ± 1°		TITLE GEORGE FOREMAN GRD6090B COSTCO	
DESIGNED JB	DRAWN JB	MATERIAL N/A	PART NO. PXXXXX
DATE 08/12/19	DATE 08/12/19	FINISH N/A	SHEET 2 OF 2

REV	ECN #	DESCRIPTION	DATE	BY
1	XXXX	FOR PRICING	08/13/19	JB

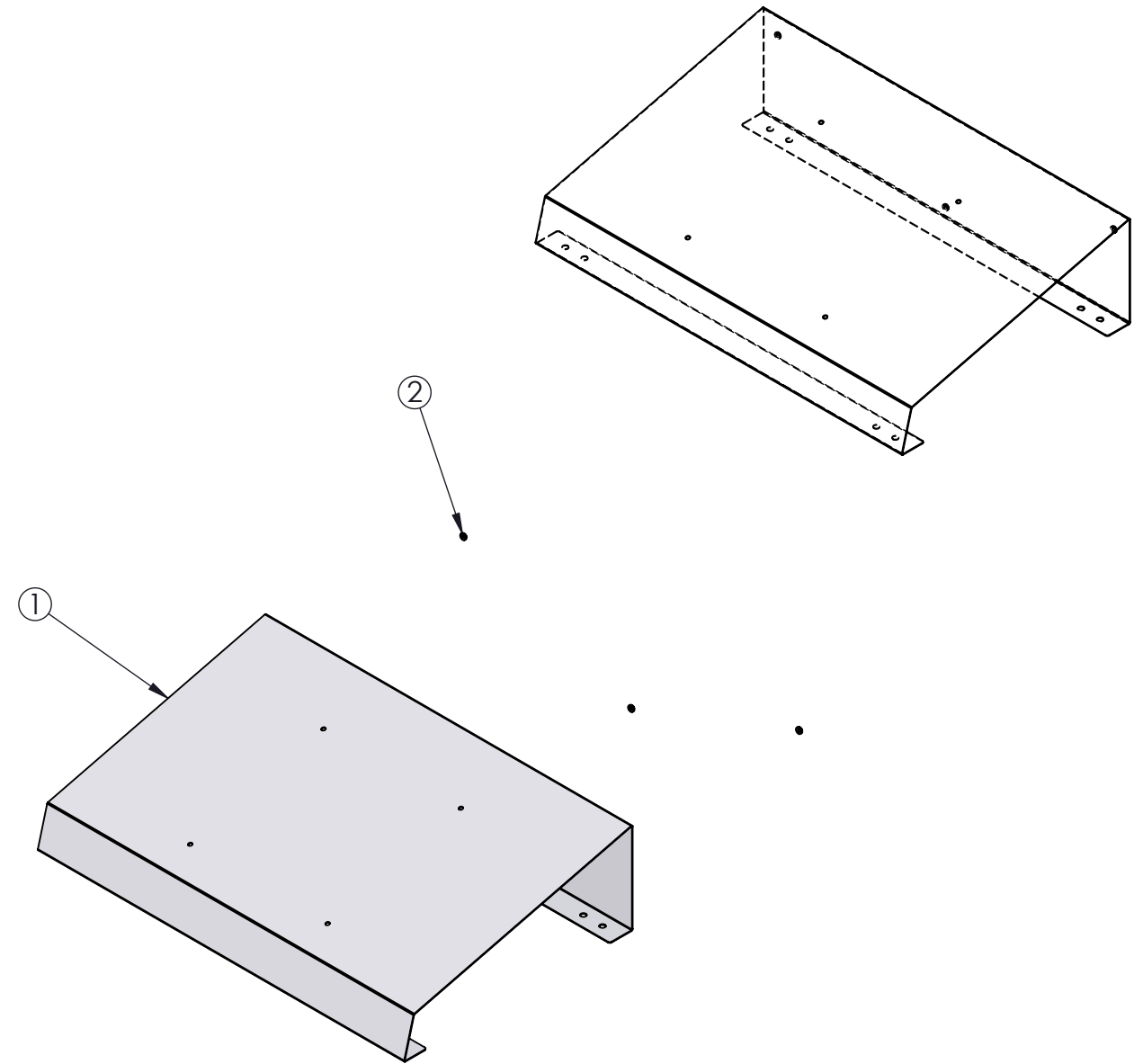
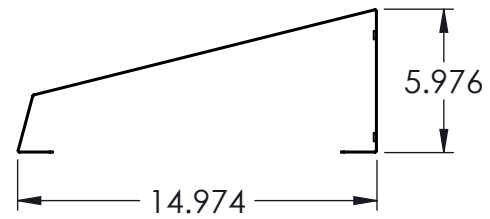
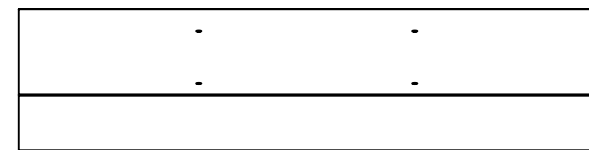
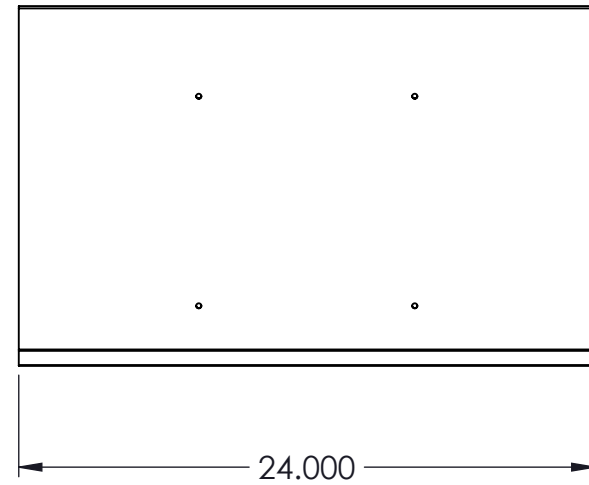

ITEM NO.	PART NO.	DESCRIPTION	QTY.
2	P33318	PEM NUT SELF CLINCH 10-24 X .038" #SS-024-1 ZI	3
1	PXXXXX	BASE	1

TOLERANCES UNLESS OTHERWISE NOTED XXX ± .015 XX ± .030 HOLE ± .005 ANGLE ± 1°		TITLE BASE SUB-ASSEMBLY	
DESIGNED JB	DRAWN JB	MATERIAL N/A	PART NO. PXXXXX
DATE 08/12/19	DATE 08/13/19	FINISH SKY WHITE	SHEET 1 OF 1

REV	ECN #	DESCRIPTION	DATE	BY
1	XXXX	FOR PRICING	08/13/19	JB

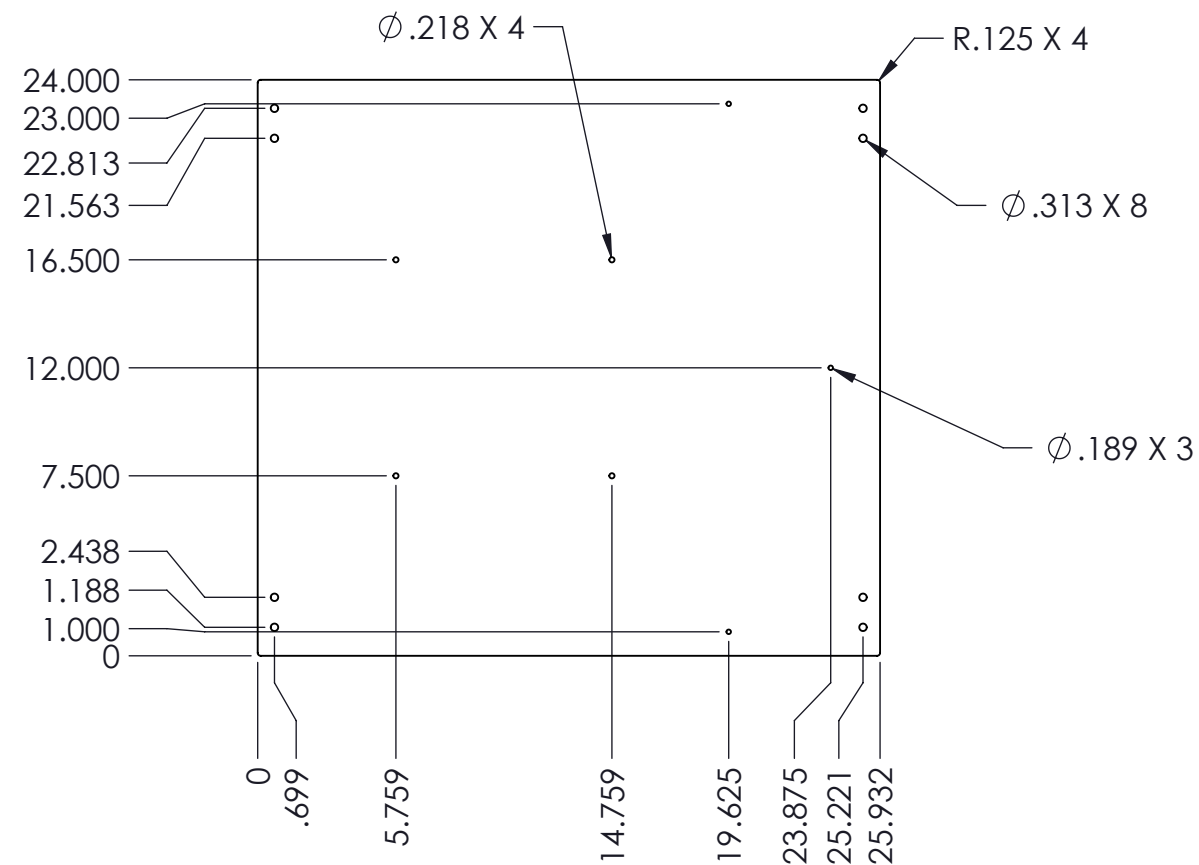
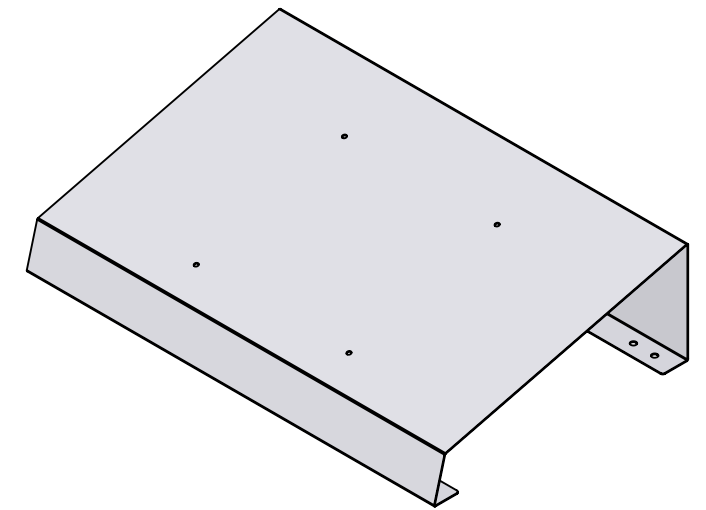
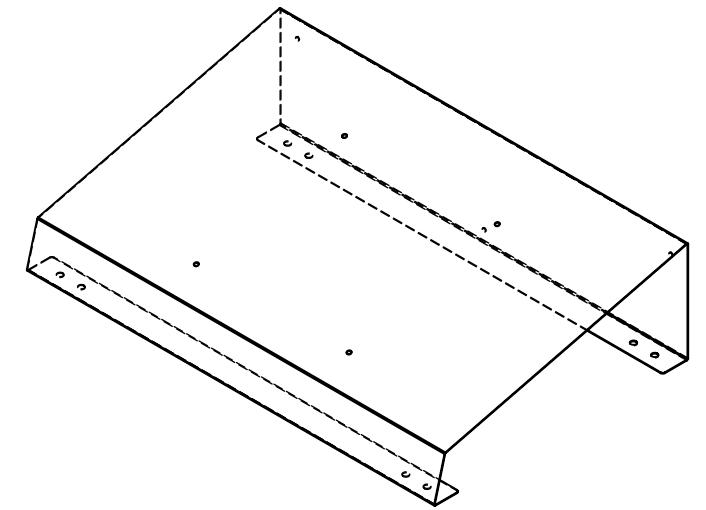
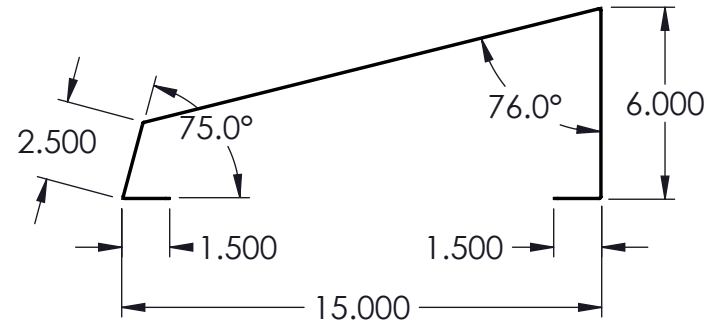
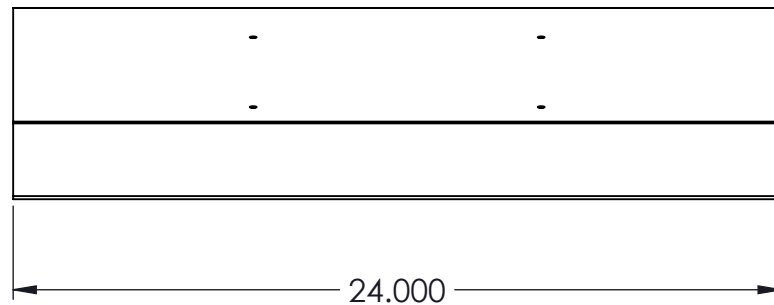
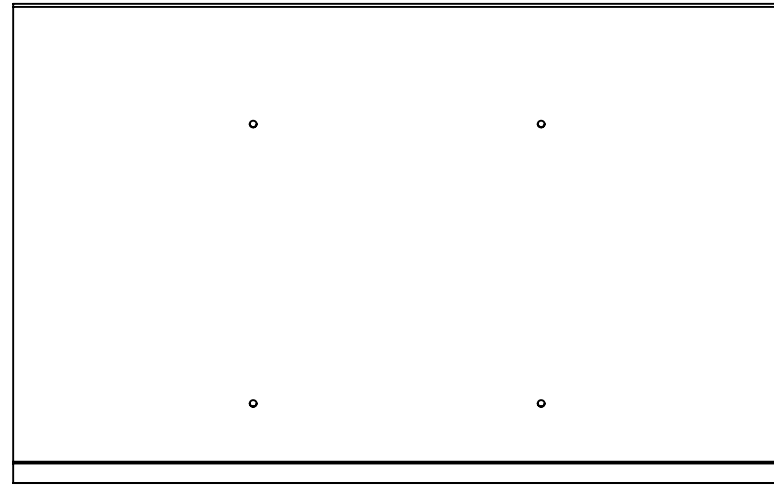

TOLERANCES UNLESS OTHERWISE NOTED XXX ± .015 XX ± .030 HOLE ± .005 ANGLE ± 1°		TITLE BASE	
DESIGNED JB	DRAWN JB	MATERIAL Material <not specified>	PART NO PXXXXX
DATE 08/12/19	DATE 08/13/19	FINISH XXXXXXXXXX	SHEET 1 OF 1

REV	ECN #	DESCRIPTION	DATE	BY
1	XXXX	FOR PRICING	08/13/19	JB

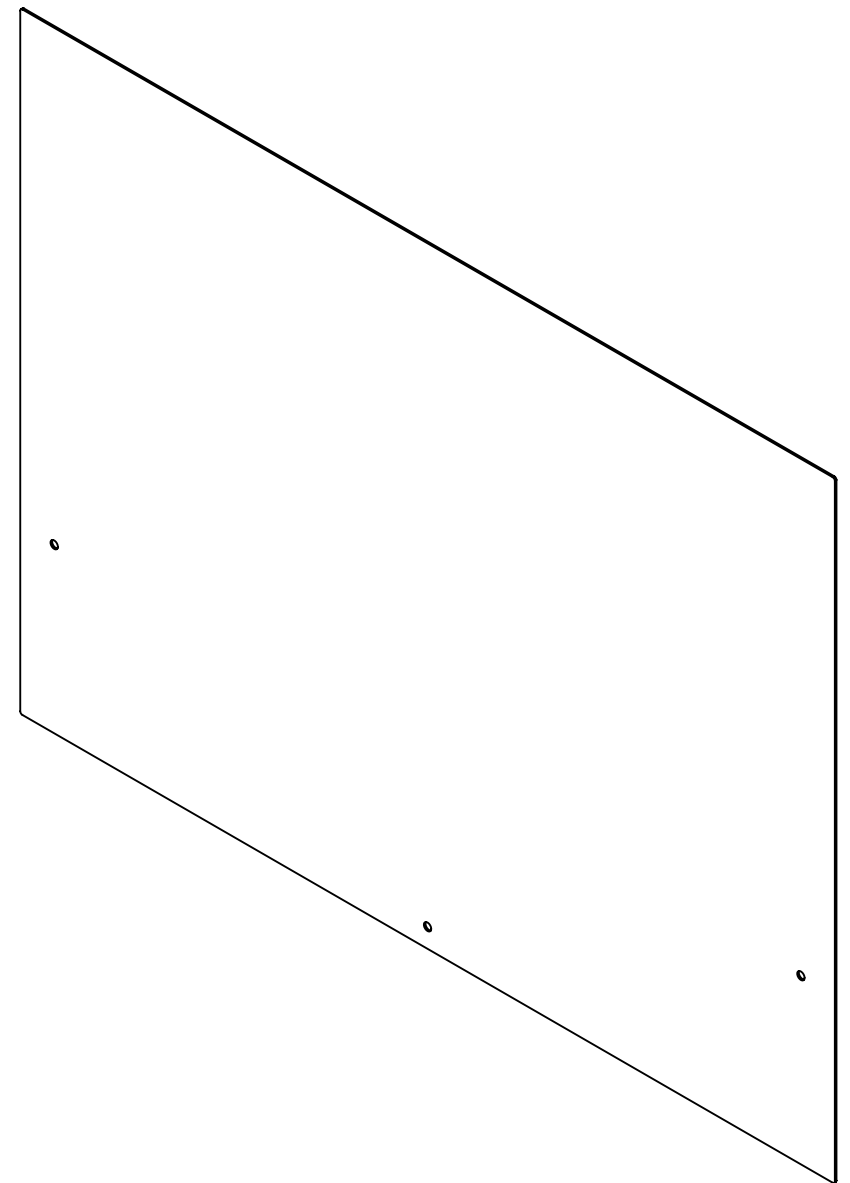
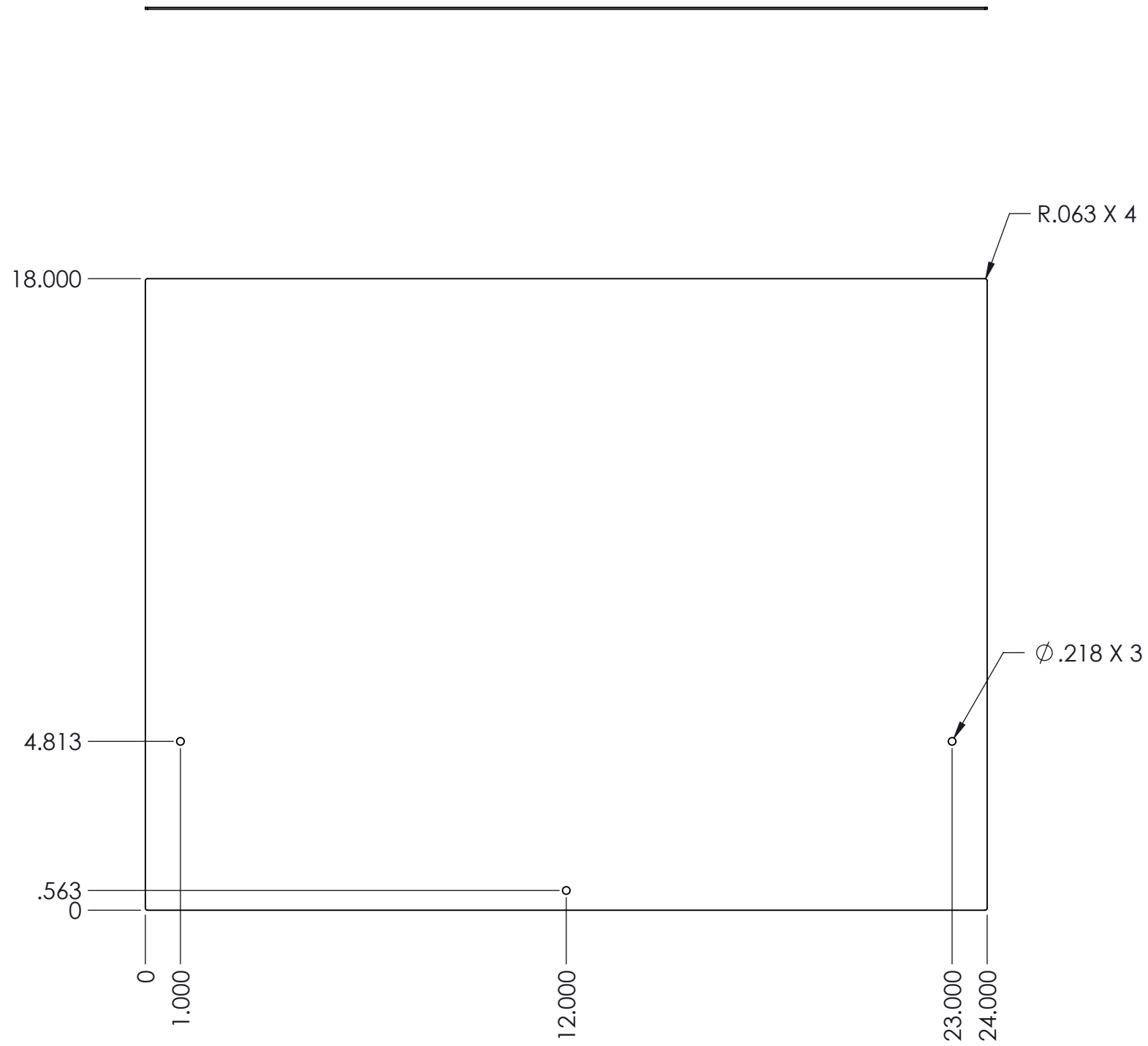

TOLERANCES UNLESS OTHERWISE NOTED XXX \pm .015 XX \pm .030 HOLE \pm .005 ANGLE \pm 1°		TITLE BACK	
DESIGNED JB	DRAWN JB	MATERIAL 18 GA (.048) CRS	PART NO PXXXXX
DATE 08/12/19	DATE 08/13/19	FINISH SKY WHITE	SHEET 1 OF 1

REV	ECN #	DESCRIPTION	DATE	BY
1	XXXX	FOR PRICING	08/12/19	JB

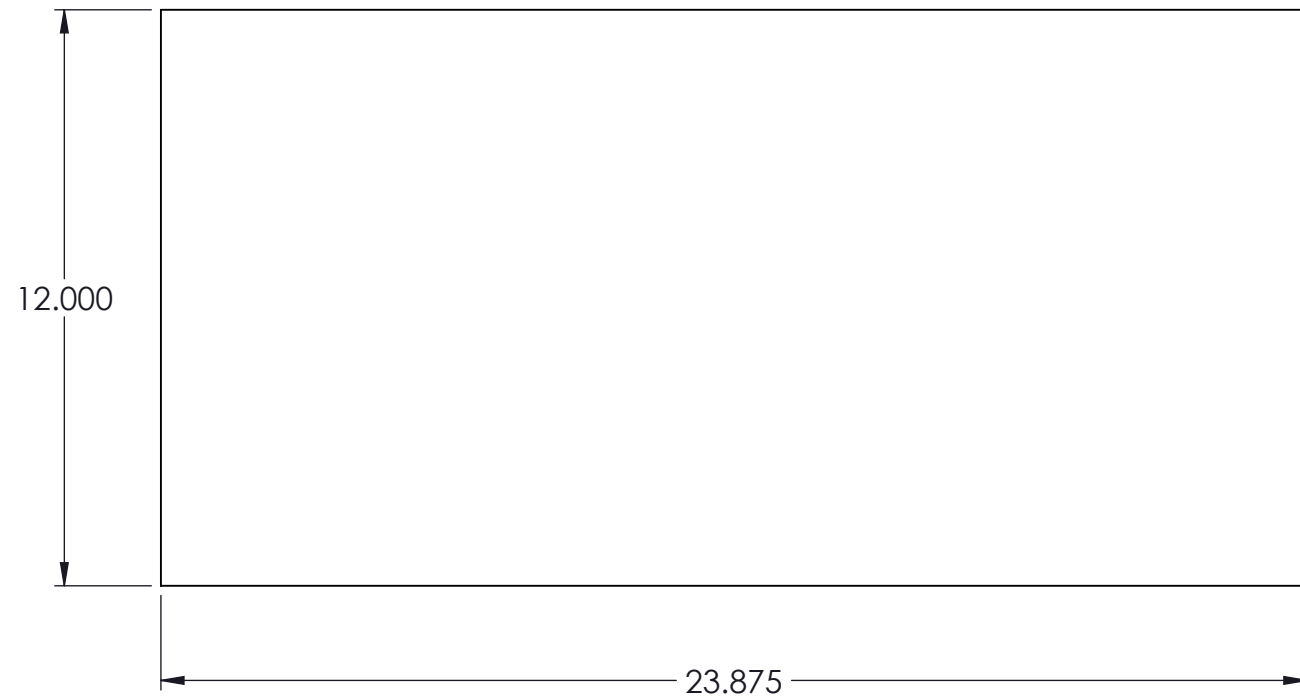

TOLERANCES UNLESS OTHERWISE NOTED XXX ± .015 XX ± .030 HOLE ± .005 ANGLE ± 1°		TITLE GRAPHIC BACKER COSTCO	
DESIGNED JB	DRAWN JB	MATERIAL STYRENE	PART NO PXXXXX
DATE 08/12/19	DATE 08/12/19	FINISH PRINTED AND FULL PSA BACKER	SHEET 1 OF 1

REV	ECN #	DESCRIPTION	DATE	BY
1	XXXX	FOR PRICING	08/12/19	JB

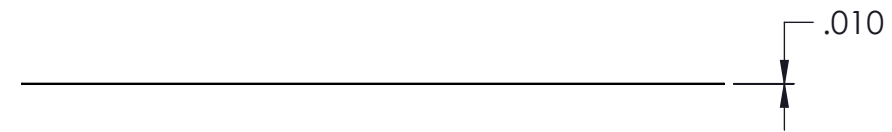
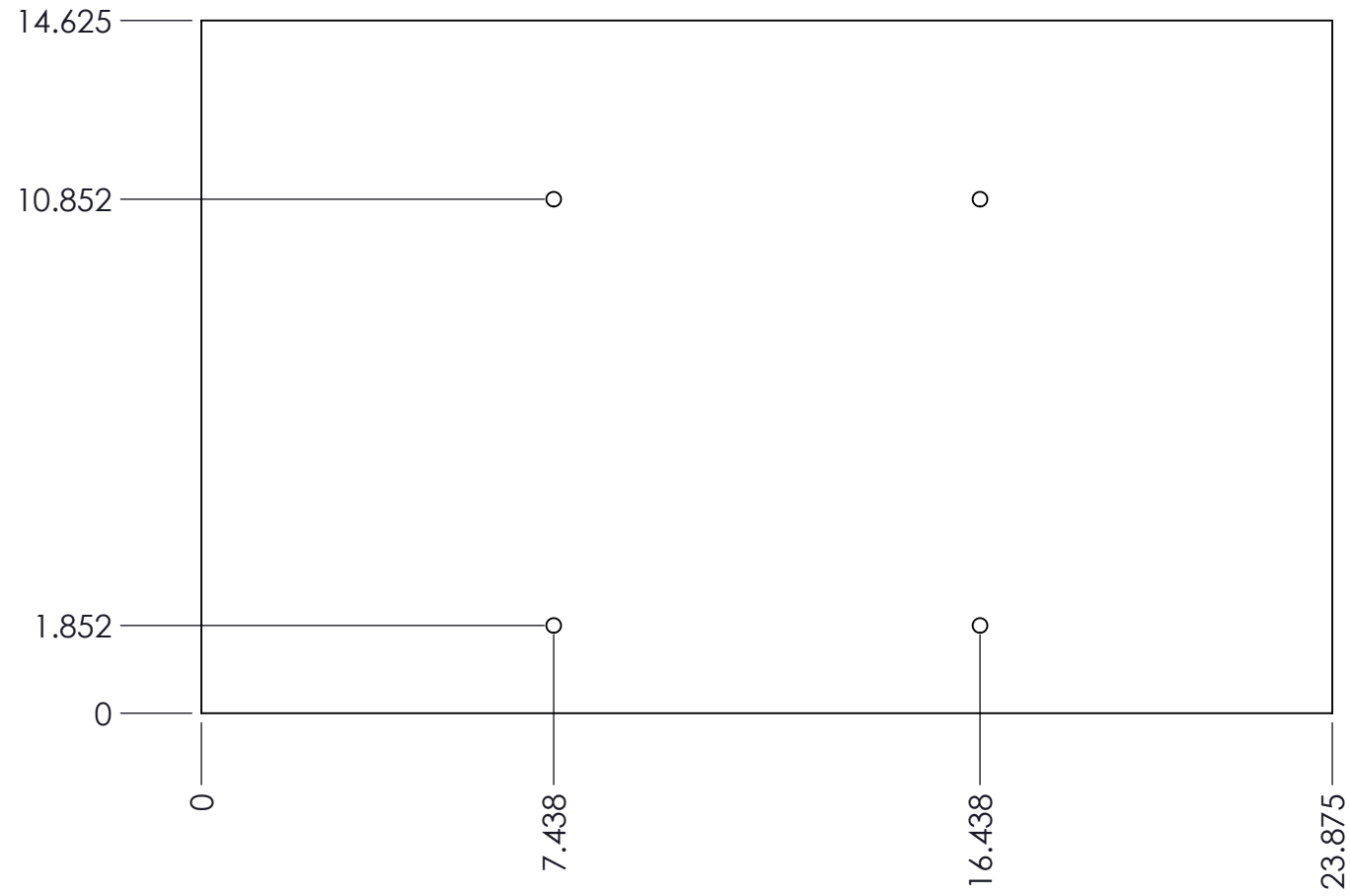

TOLERANCES UNLESS OTHERWISE NOTED XXX ± .015 XX ± .030 HOLE ± .005 ANGLE ± 1°		TITLE GRAPHIC PLATFORM COSTCO	
DESIGNED JB	DRAWN JB	MATERIAL STYRENE	PART NO PXXXXX
DATE 08/12/19	DATE 08/12/19	FINISH PRINTED AND FULL PSA BACKER	SHEET 1 OF 1

REV	ECN #	DESCRIPTION	DATE	BY
1	XXXX	FOR PRICING	08/12/19	JB

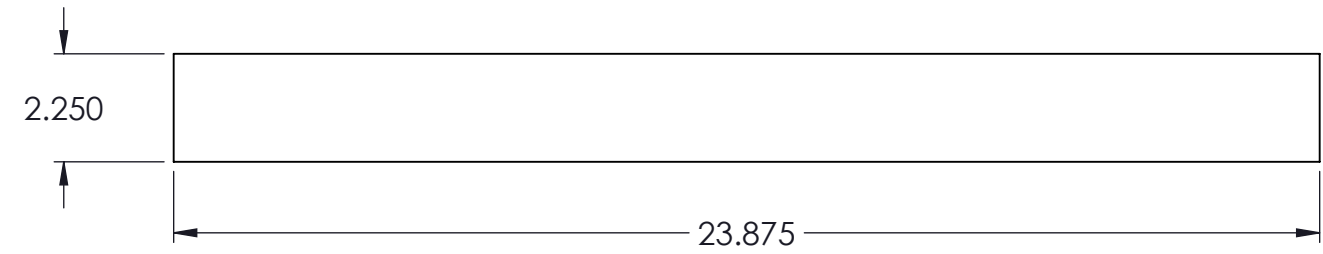
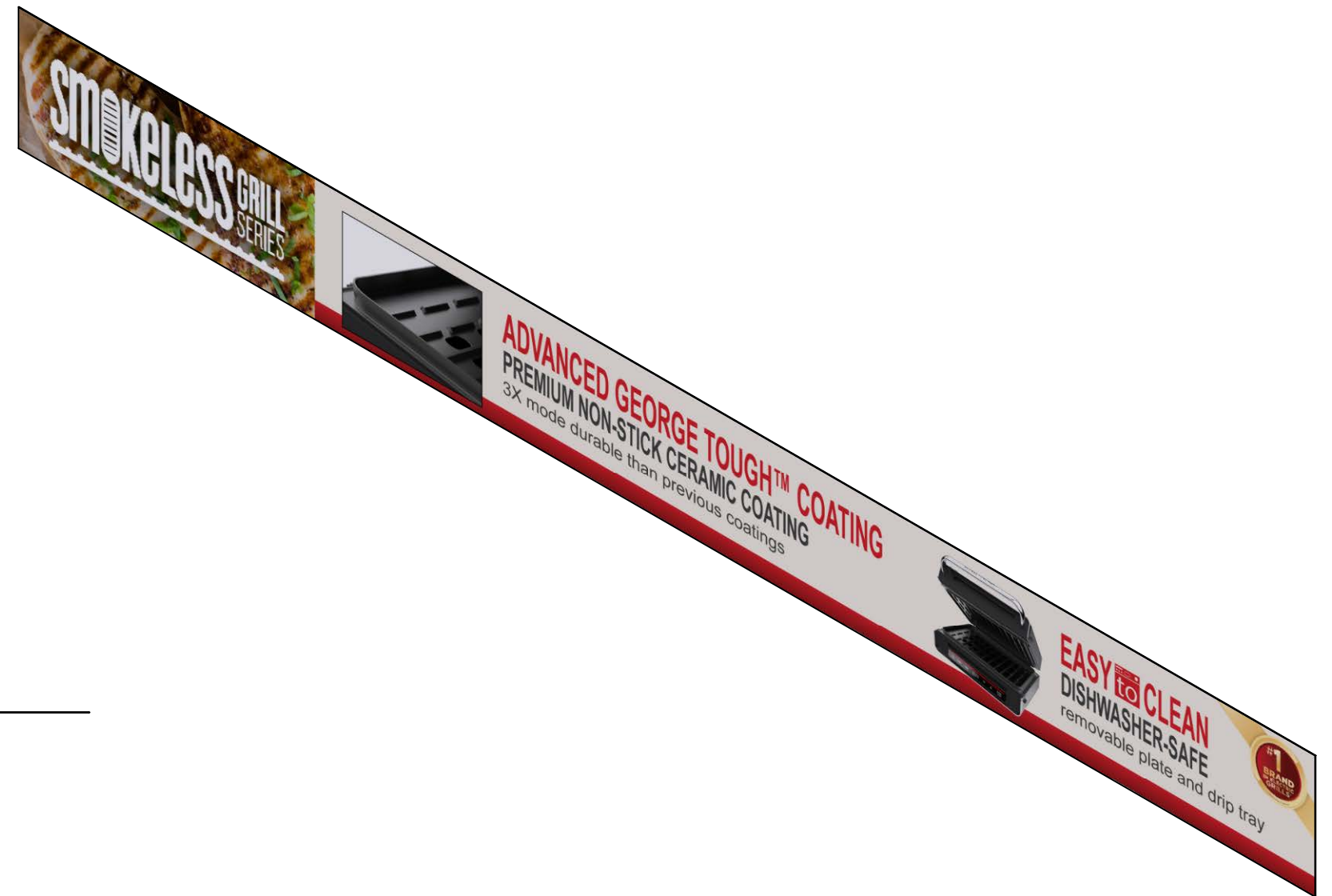

TOLERANCES UNLESS OTHERWISE NOTED XXX ± .015 XX ± .030 HOLE ± .005 ANGLE ± 1°		TITLE GRAPHIC FRONT COSTCO	
DESIGNED JB	DRAWN JB	MATERIAL STYRENE	PART NO PXXXXX
DATE 08/12/19	DATE 08/12/19	FINISH PRINTED AND FULL PSA BACKING	SHEET 1 OF 1

REV	ECN #	DESCRIPTION	DATE	BY
1	XXXX	FOR PRICING	08/01/19	JB

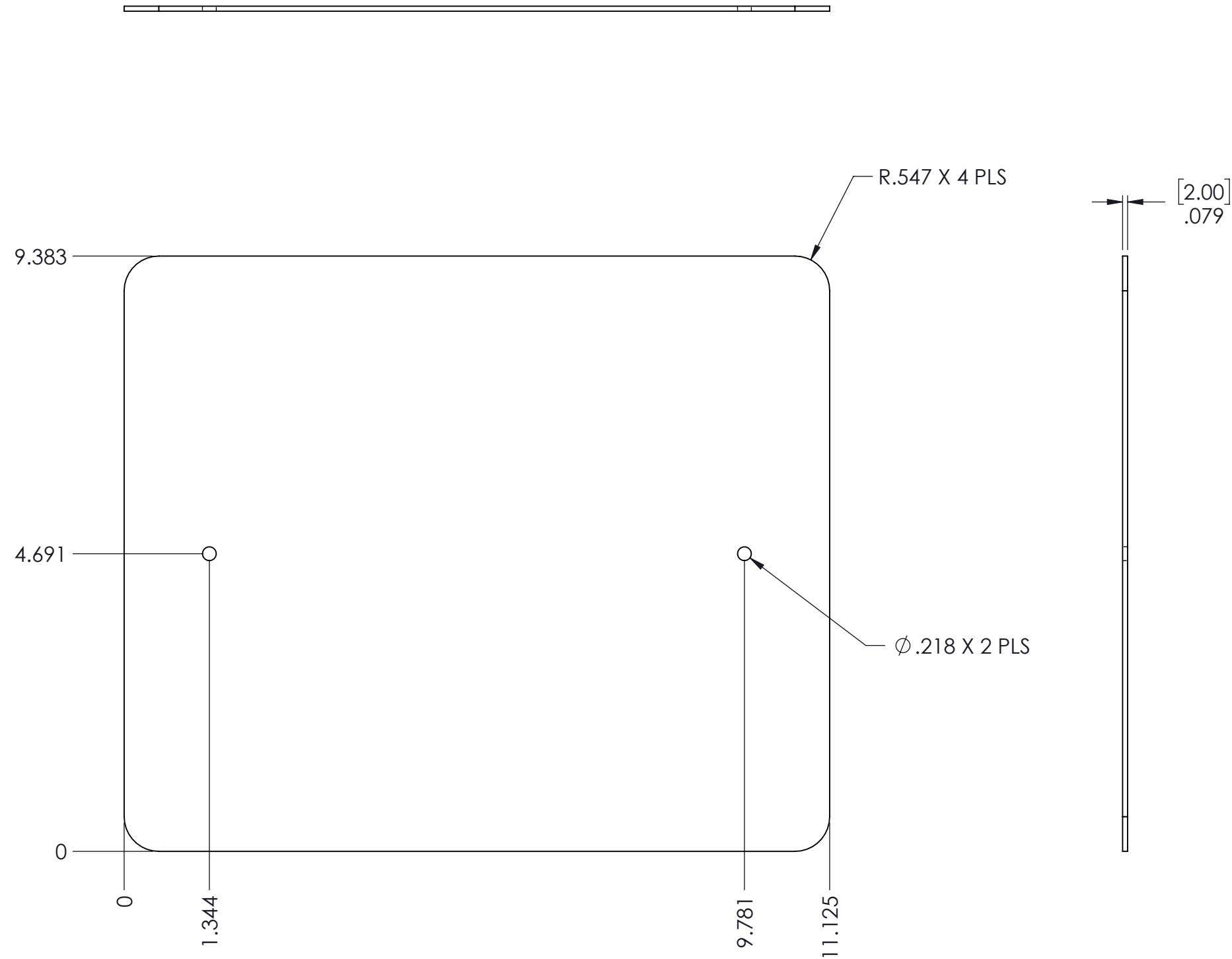

PRINT FRONT SIDE ON CLEAR 2MM PETG

TOLERANCES UNLESS OTHERWISE NOTED XXX ± .015 XX ± .030 HOLE ± .005 ANGLE ± 1°		TITLE GRAPHIC ON GRILL 1	
DESIGNED JB	DRAWN JB	MATERIAL PETG	PART NO PXXXXX
DATE 08/01/19	DATE 08/01/19	FINISH PRINTED ON CLEAR	SHEET 1 OF 1